

digital

**RS08/RS09 DECdisk
preventive maintenance
procedure**

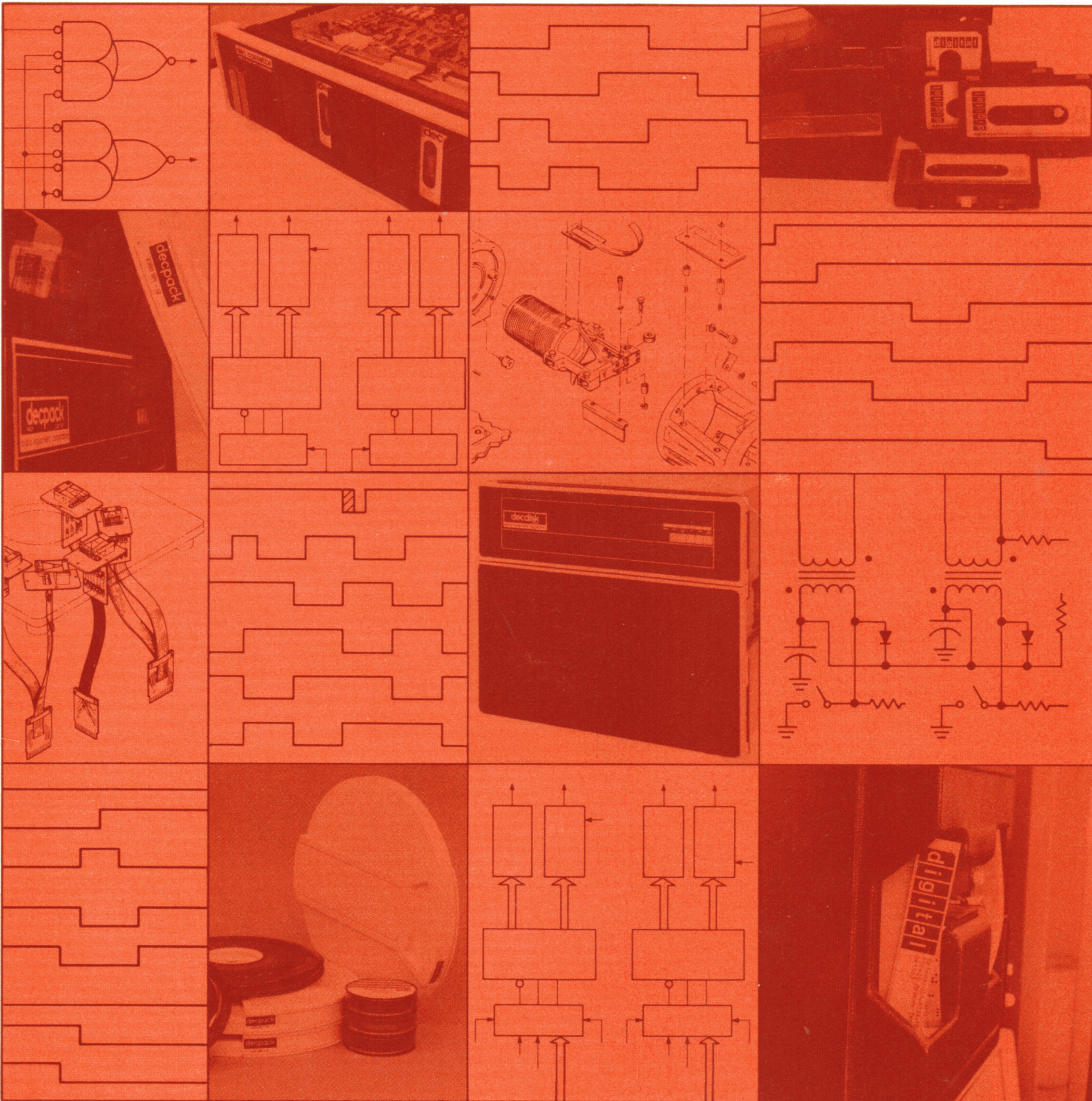

**RS08/RS09 DECdisk
preventive maintenance
procedure**

DEC-FS-HRSPM-A-D

1st Edition, January 1975

Copyright © 1975 by Digital Equipment Corporation

The material in this manual is for informational purposes and is subject to change without notice.

Digital Equipment Corporation assumes no responsibility for any errors which may appear in this manual.

Printed in U.S.A.

The following are trademarks of Digital Equipment Corporation, Maynard, Massachusetts:

DEC	PDP
FLIP CHIP	FOCAL
DIGITAL	COMPUTER LAB

CONTENTS

		Page
1.0	APPLICABLE OPTION DESIGNATIONS	1
2.0	PERIODIC PREVENTIVE MAINTENANCE	1
3.0	EQUIPMENT AND PARTS REQUIRED	1
4.0	DIAGNOSTICS AVAILABLE	3
5.0	RELATED DOCUMENTATION	4
6.0	QUARTERLY FIELD SERVICE PREVENTIVE MAINTENANCE (2000 Hrs)	4
7.0	SEMI-ANNUAL FIELD SERVICE PREVENTIVE MAINTENANCE (4000 Hrs)	4
8.0	ANNUAL FIELD SERVICE PREVENTIVE MAINTENANCE (or 8000 Hrs)	10
APPENDIX A	TIMING TRACK WRITER	
A.1	PROCEDURE FOR TIMING TRACK CHECK	A-1
A.2	RS08 TIMING TRACK WRITER PROCEDURE	A-1
A.3	RS09 TIMING TRACK WRITER PROCEDURE	A-4
APPENDIX B	MAINTENANCE PROGRAMS	
B.1	RS08 MAINTENANCE PROGRAM	B-1
APPENDIX C	SPECIAL CALIBRATION REQUIREMENTS	
C.1	REPLACING THE SHOES	C-1
C.2	MEASURING SURFACE MODULATION	C-2
C.3	DETERMINING REFERENCE TRACK (RS09)	C-2
C.3.1	Determine Average Track for Each Matrix	C-2
C.3.2	Adjusting the Data Read Amplifiers	C-4
C.3.2.1	Using the RS09 Alignment Program to Adjust Data Read Amplifiers	C-4
C.3.2.2	Using the RF11 Multi-Disk Program to Adjust Data Read Amplifiers	C-8
C.4	RS08 DATA TRACK GAIN (AGC EQUALIZATION)	C-9

ILLUSTRATIONS

Figure No.	Title	Page
1	RS08M/09M Repair Kit (RS Kit)	3
2	Prefilter	4
3	Absolute Filter	5
4	Measuring Gain, the A Track Over One Revolution	7
5	Measuring Slice Level – A Track	7
6	Measuring the Slice of the B Track	8
7	Measuring the Slice of the C Track	9
8	Placement of Fowler Gauge for Disk Runout Check	13
A-1	RS08 Timing Track Writer (RS08-TA)	A-2
A-2	Timing Track A Display	A-3
A-3	550 μ s Gap Display	A-3
A-4	RS09 Timing Track Writer (RS09-TA)	A-4
C-1	Aligning the Heads	C-1
C-2	RS08M Data Sheet	C-3
C-3	RS Calibration Sheet	C-6
C-4	RS08M Head Data Sheet	C-7

TABLES

Table No.	Title	Page
1	Preventive Maintenance Schedule	1
2	Equipment and Parts	2
3	Gain and Slice Adjustment Check	6
4	DC Voltages	10
C-1	RS09, RS11 Jumpers to Increase Gain	C-4
C-2	Control Switch Settings	C-8
C-3	RS08 Jumpers to Increase Gain	C-9

1.0 APPLICABLE OPTION DESIGNATIONS

RF08/RS08
 RF09/RS09
 RF15/RS09
 RF11/RS11

2.0 PERIODIC PREVENTIVE MAINTENANCE

3.0 EQUIPMENT AND PARTS REQUIRED

The equipment and parts required for RS preventive maintenance are listed in Table 2.

**Table 1
 Preventive Maintenance Schedule**

					Para. Ref.	Time (est.)
Quarterly (or 2000 hrs)					6.0	1 hr
Semi-Annual (4000 hrs)					7.0	2 hr
Annual (8000 hrs)					8.0	3 hr
5 Yr (40,000 hrs)					9.0	4 hr
X	X	X	X	Install F-Coded ECOs (as required)	6 (1)	variable
X	X	X	X	Clean prefilter	6 (2)	5 min
X	X	X	X	Clean cabinet filter	6 (3)	5 min
	X	X	X	Replace absolute filter	7 (1)	10 min
X	X	X	X	Vacuum cabinet	6 (4)	10 min
X	X	X	X	Inspect wiring for loose connections	8 (1)	5 min
X	X	X	X	Inspect and replace defective lights	6 (5)	5 min
		X	X	Observe dc voltages	8 (2)	10 min
			X	Replace motor	Ref. IPB	60 min
		X	X	Remove disk – clean it and all heads	8 (3)	60 min
	X	X	X	Observe gain and slice of each amp	7 (2)	30 min
X	X	X	X	Run diagnostic	Ref. MainDEC	30 min

**Table 2
Equipment and Parts**

Equipment/Part	Model/Part No.
Multimeter	Simpson, Micronta, or equivalent
Oscilloscope	Tektronix 453 or equivalent
Probe, Oscilloscope (voltage X10) (2)	Tektronix P6010
Tool Kit, Field Service	DEC 29-18303
RS Kit (Figure 1)	RS Kit
Cleaning Kit (DC4, Chevron 325, & Kaydrys)*	DEC option RSC01
Kimwipes**	
Small brush**	
Head cleaner**	
Head**	
25 gram	DEC 30-05982-25GR
31 gram	DEC 30-05982-31GR
Disk, Metal* (RS08, RS09)	DEC 30-05981
RS08 TTW	DEC RS08-TA
RS09/11/15 TTW	DEC RS09-TA
RS Motor (60 Hz) and Hub Assembly	DEC 74-06866-1
RS Motor (50 Hz) and Hub Assembly	DEC 74-06866-2
RS Absolute Filter	DEC 12-09388
RS Prefilter	DEC 74-07181

*Included in RS Kit but may be reordered separately.

**May be helpful (not supplied in kit).

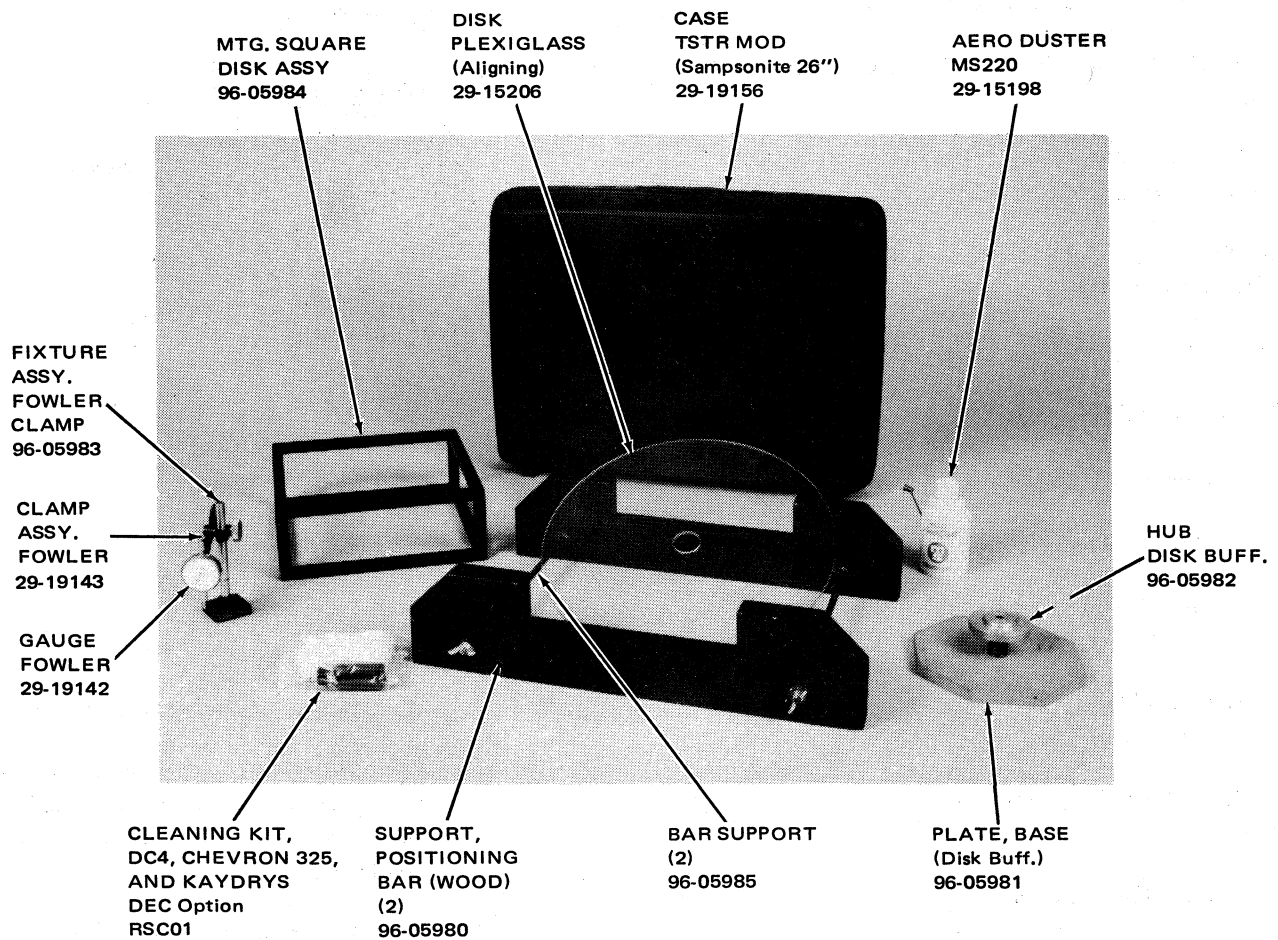

NOTE:
RS Kit Cleaning Replacement Procedure (not shown) A-SP-RS Kit-0-1

Figure 1 RS08M/09M Repair Kit (RS Kit)

4.0 DIAGNOSTICS AVAILABLE

The following diagnostics are available for preventive maintenance of RS:

Maindec 08-DIRFA	RF08 Disk Data Test	Maindec 11-DZRFA	RF11 Static Test
Maindec 08-D5FA	RF08 Multi-Disk Test	Maindec 11-DZRFB	RF11 Disk Data Test
Maindec 09-D5CA	RF09 Diskless Test	Maindec 11-DZRFC	RF11 Multi-Disk Test
Maindec 09-D5AA	RF09 Disk Data Test	Maindec 15-D5AA	RF15 Disk Data Test
Maindec 09-D5BA	RF09 Multi-Disk Test	Maindec 15-D5BA	RF15 Multi-Disk Test
		Maindec 15-D5CA	RF15 Diskless Test
		Maindec 15-D5RA	RS09 Alignment Program

5.0 RELATED DOCUMENTATION

RF11/RS11 DECdisk System Manual	DEC-11-HRFD-D
RF15/RS09 DECdisk System Maintenance Manual, Vol. I	DEC-15-H2IC-D
RF08 Disk Control and RS08 Disk Maintenance Manual	DEC-08-HIEA-D
RS08 Disk Memory IPB	DEC-RS08-IPB-1
RF08 Rotating File Print Set	
RS08 Disk Memory Print Set	
RS08-M Disk Assembly Print Set	
RS08-P Chassis Assembly Logic Prints	
RF11/RS11 DECdisk System Engineering Drawings	
RF15/RS09 DECdisk System Print Set	
RF09 Rotating File Print Set	
DEC-ECO-LOG	
RS09 Timing Track Writer Maintenance Manual	DEC-FS-HRSAA-A-D
RS08 Timing Track Writer Maintenance Manual	DEC-FS-HRS8B-A-D

6.0 QUARTERLY FIELD SERVICE PREVENTIVE MAINTENANCE (2000 Hrs)

1. Review the ECO status of the RS and install any F-coded ECOs as required.

CAUTION

Power disk cabinet down before cleaning filters.

2. Remove and clean the prefilter (Figure 2).
 - a. Remove 3 screws from top cover.

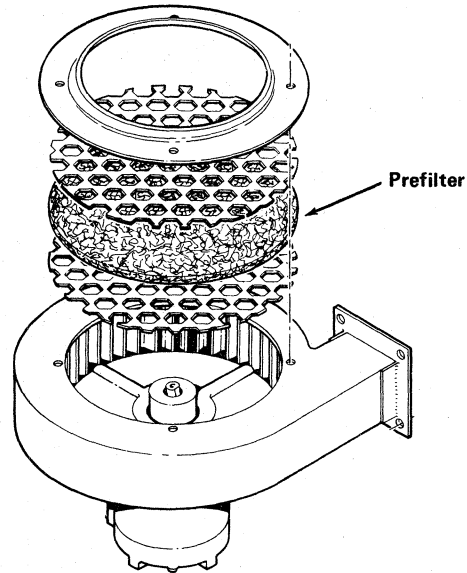

Figure 2 Prefilter

- b. Remove cover assembly and filter.
 - c. Vacuum filter; if extremely dirty it may be replaced or washed thoroughly in warm soapy water. (Do not replace until completely dry.)
 - d. Replace filter and cover assembly.
3. Remove and clean the cabinet filter.
 4. Vacuum the cabinet thoroughly.
 5. Inspect the indicator panel for defective light bulbs; replace if necessary. (Refer to Appendix B for light check routine or check while running appropriate diagnostic.)

7.0 SEMI-ANNUAL FIELD SERVICE PREVENTIVE MAINTENANCE (4000 Hrs)

1. Replace absolute filter (Figure 3).
 - a. Power the disk cabinet down.
 - b. Remove the plastic hose from the filter housing top air duct.
 - c. Remove the 8 screws from the top air duct cover assembly; remove the cover.

d. Remove the old filter, ensuring that the interior of the bracket is clean; install the new filter.

e. Replace the air duct cover assembly.

f. Replace the hose.

g. Power disk cabinet up.

2. Observe gain and slice of each G085 amplifier (Table 3).

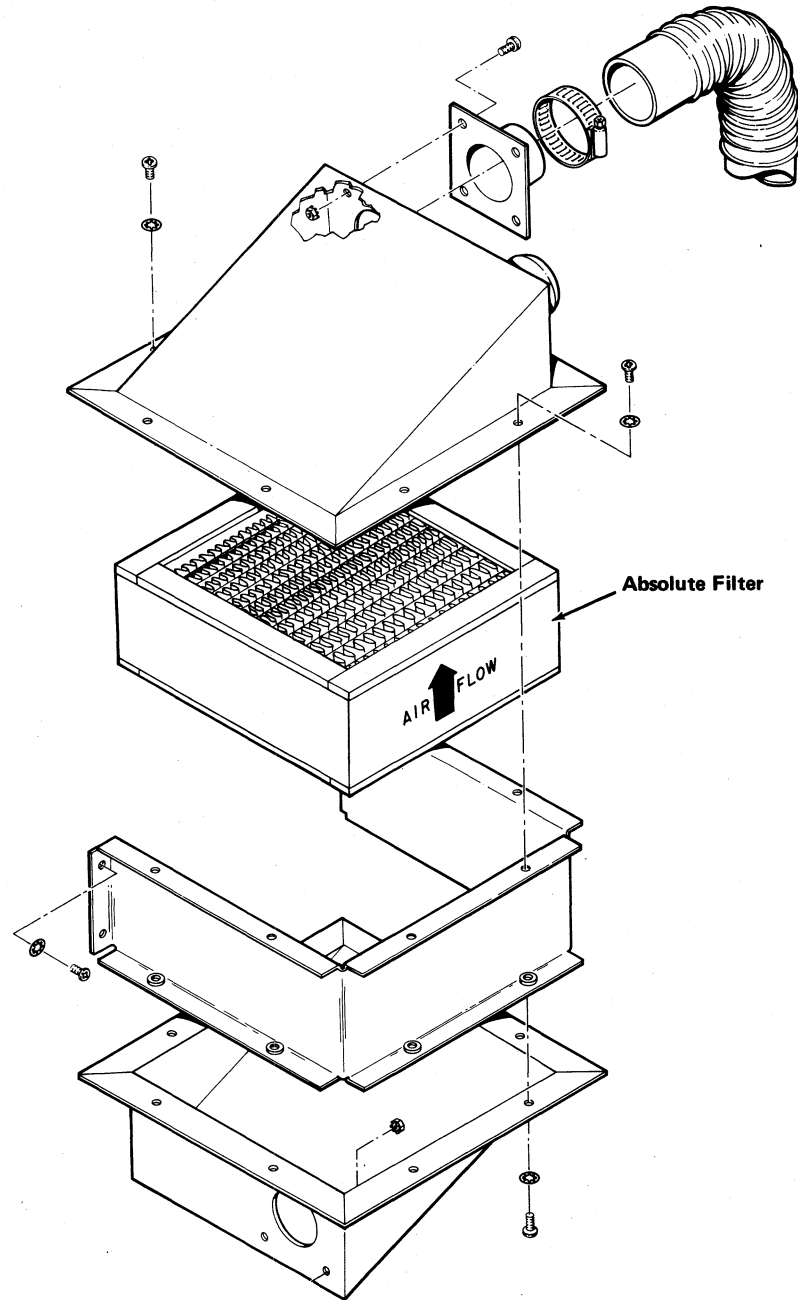

Figure 3 Absolute Filter

Table 3
Gain and Slice Adjustment Check

	Timing Track "A"	Timing Track "B"	Timing Track "C"	Data Track		Data Track
				Matrix 0	Matrix 1	
Disk	← RS08/RS09 →			← RS09 only →		← RS08 only →
Channel 1 Test Point	B02E	B03E	B04E	B05E	B07E	B12E
	← Ground probe to eliminate ringing (i.e., B02C, B03C, etc.) →					
Channel 2 Test Point	A02T	A03T	A04T	A05T	A07T	A12T
	← Ground probe to stabilize signal (i.e., A03C, A04C, etc.) →					
Sweep Time	← 5 ms/cm (Figure 4) →					
Gain: Slice:	2 μs/cm	0.2 μs/cm	2 μs/cm	0.5 μs/cm		0.5 μs/cm
Gain (Ch 1 & Ch 2)	0.1 V/cm (X10 probe, dc)			0.5 V/cm (X10 probe, dc)		
Mode	Channel 2 for Gain; ALT for Slice, then ADD					
Trigger	Channel 1 (only) or Normal					
A Sweep Mode	Normal					
A Triggering	Line, ac, Level and Slope (-)					
Program	See Appendix B for maintenance program or run Disk Data Test			RF11: RF11 Multi-disk Test (STAMP section) RF15: RS09 Alignment Program (SA 200)	RF08: Disk Data Test	
Specifications	See Figure 5	Av. Gain = 6 V p-p; Slice = 1.4 V See Figure 6	See Figure 7	Gain and Slice level for reference track is printed on the disk for each matrix. (Refer to Appendix C if not printed on disk)		Gain = 7 V p-p Slice = 1.6 V
Action	Gain:	Check average Gain over one revolution: Measure peak-to-peak voltage at lowest point and highest point; add these measurements together and divide by 2.			Write alternate 1s and 0s in reference track; read reference track and set up Gain and Slice for each matrix.	
	Slice:	A Zero crossing should be achieved on channel 2 by locating the gap and setting the zero line on the trace as it passes through the gap as shown in Figure 4. Channel 1 trace should be set as shown in Figure 5. Select ADD on scope and calculate Slice by: $\text{Slice} = \frac{A + B - \text{Overshoot}}{2}$			Write all 1s in Track 0; begin reading track 0. Stopping computer after starting to read allows continuous read. Check Gain & Slice.	
Adjustment	Gain: R21 ("A" section of G085); Slice: R32 ("B" section of G085)					

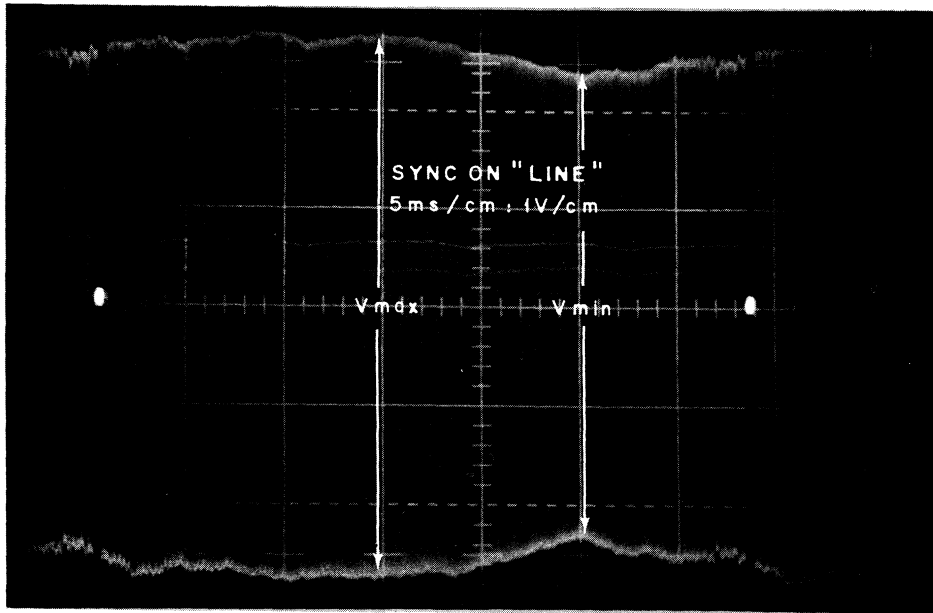

Figure 4 Measuring Gain, the A Track Over One Revolution

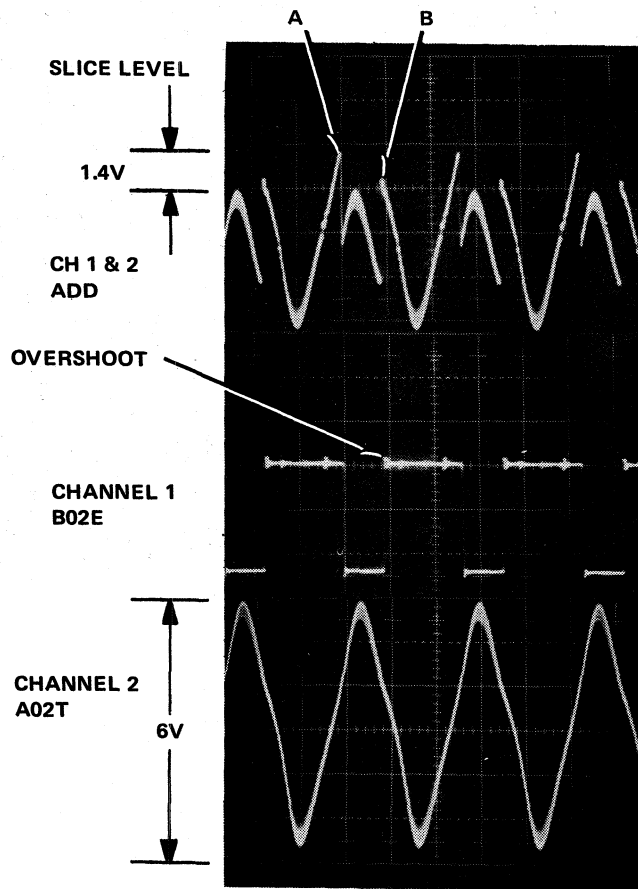

Figure 5 Measuring Slice Level – A Track

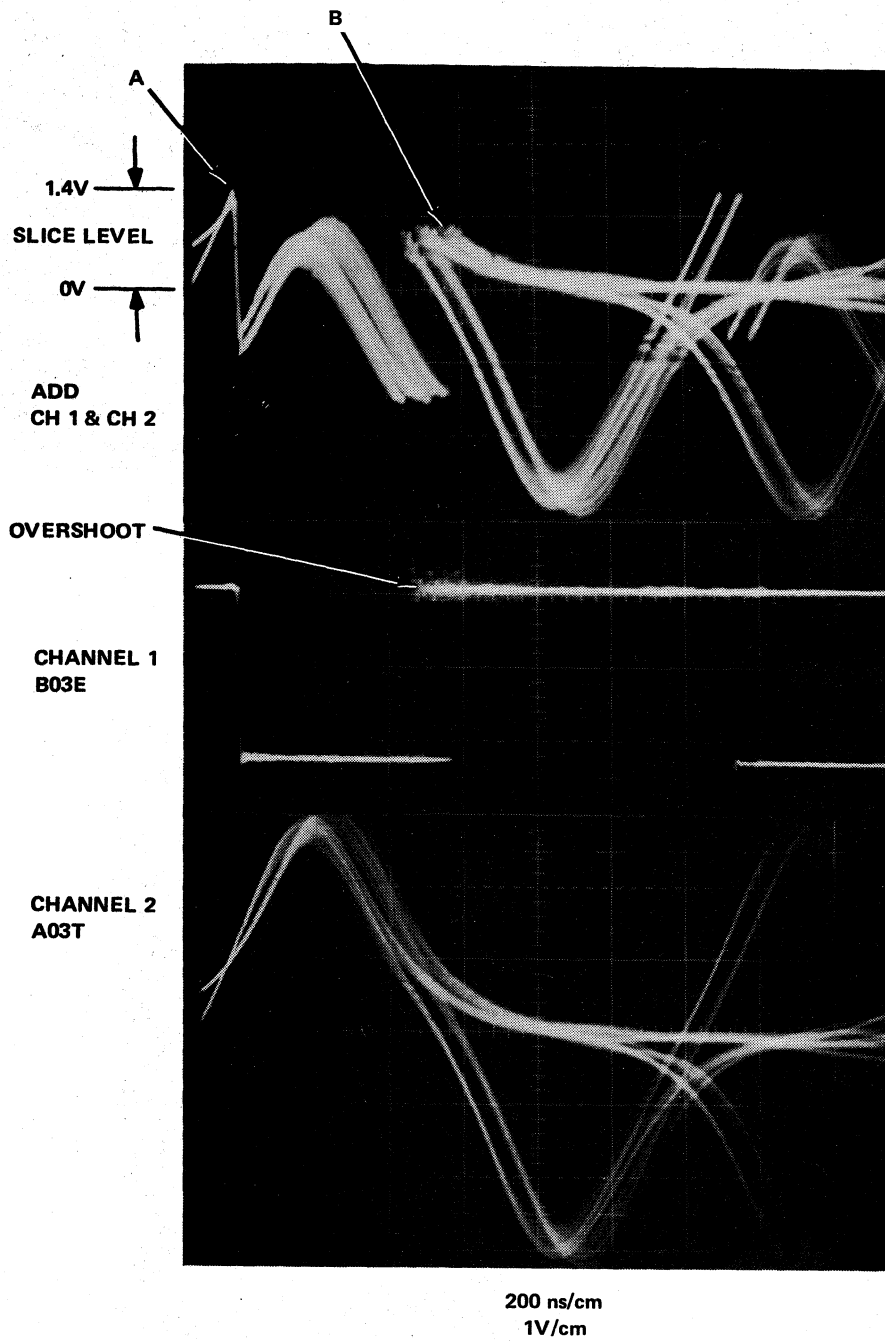

Figure 6 Measuring the Slice of the B Track

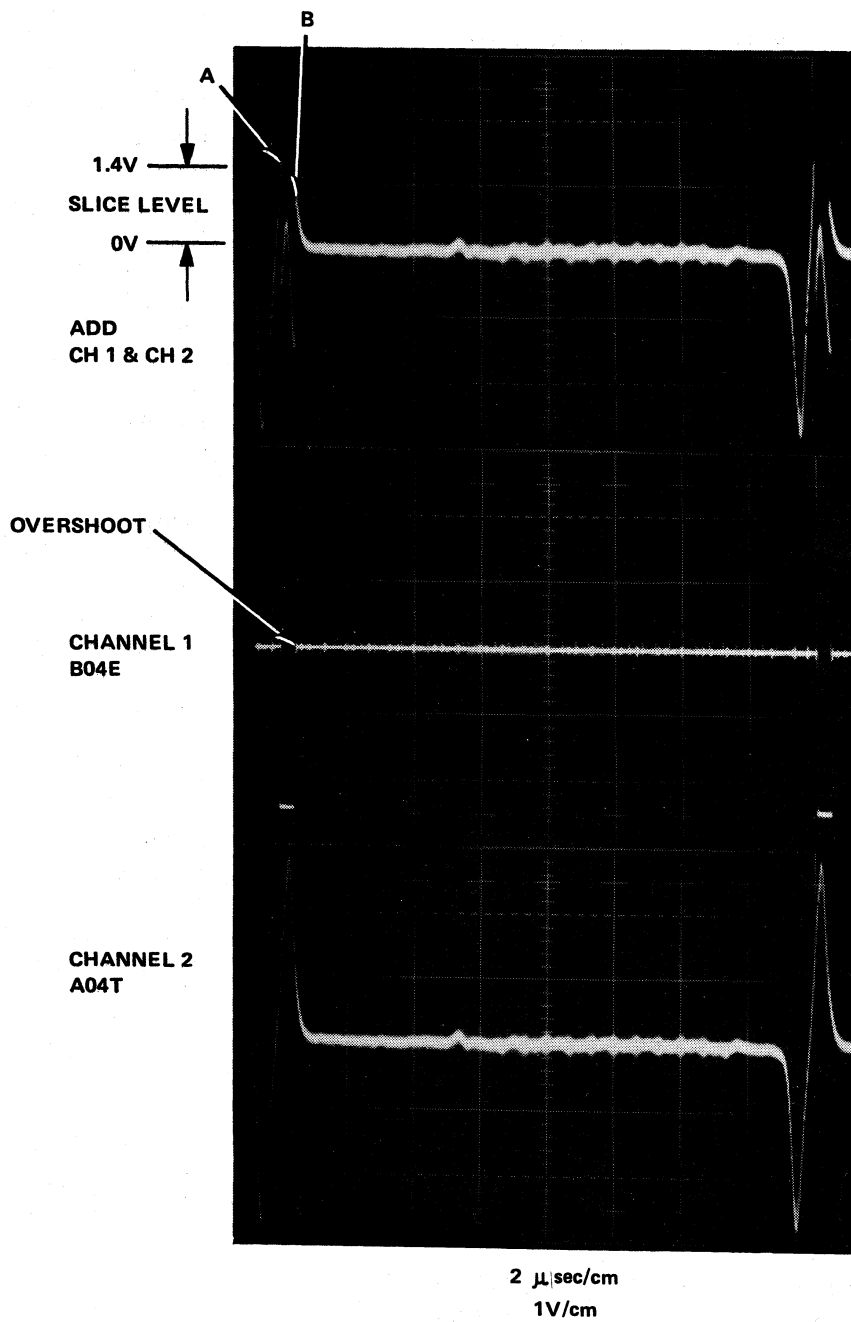

Figure 7 Measuring the Slice of the C Track

8.0 ANNUAL FIELD SERVICE PREVENTIVE MAINTENANCE (or 8000 Hrs)

1. Inspect all ac and dc power wiring for loose connections and cracked insulation.
2. Observe dc voltages. Table 4 lists specifications for each voltage.
3. Remove disk surface; clean it and all heads.
 - a. Check equipment necessary (see Figure 1).
 - b. Power cabinet down.
 - c. Remove hose from disk housing; insert a Kimwipe into the hose.
 - d. Disconnect all motor power connectors from power supply.
 - e. Remove all cable connectors from RS locations RS08: A1, A17, A18, A19, A20.
 - f. With 5/8" wrench or crescent, remove four bolts that secure disk assembly to cabinet, one on each corner at the base.
 - g. A disk mounting square can be found in the RS Kit; place it on a convenient table or bench in a clean area.
 - h. Remove the disk assembly; slide it out from the front of the cabinet. In some cases the door may have to be removed first or the disk assembly can be taken out from the rear. Ensure that all five cables and power wiring are free of obstruction to avoid damage. Place the disk assembly on the square; ensure that the power wires and cables do not get in the way.
 - i. With an Allen wrench, remove the screws from the disk cover assembly. Carefully remove the cover *straight up* and set it aside. Ensure that all screws are put in a safe place to avoid losing them.
 - j. A disk buffing hub and baseplate can be found in the RS Repair Kit; place it on a convenient working surface. With an Allen wrench, remove the four Allen screws from the disk hub assembly. Remove the disk cap and set it aside. Remove the disk surface; *do not touch any part of the surface with fingers*, handle by the edge only. Place the disk on the buffing hub with its certified surface up (normally, the side which was facing down on the heads).
 - k. Carefully clean the motor hub with a Kimwipe dampened with alcohol.

**Table 4
DC Voltages**

Voltage	Maximum Allowable Ripple	I Max.	Logic Test Points
705B Power Supply			
+10 V	300 mV	3.5 A	B28A
-15 V	700 mV	24.0 A	A02B, B28B
+20 V	300 mV	4.0 A	A02A, B02B
GND			A02C, B28C
H726A-2 Power Supply			
+5 V	5 mV	7 A	

CAUTION

Perform this next step carefully to avoid damaging the head wires or upsetting the weight settings.

- l. Support the head gently with fingers underneath; brush it until all contamination is removed. Use alcohol or magtape head cleaner. Ensure that the head is clean and that no film exists on the flying surface when the job is complete.
- m. Inspect each head connector for proper seating; examine the twisted pair leads of the data cable for loose or broken connections. If head shoes are damaged refer to Appendix C for replacement and calibration procedures.
- n. There are two different kinds of platters in use: the silver Tech-Met platter and the bluish DMV platter which is made by DEC. Each platter has its own special method of cleaning. Note that even though only one side of the platter is certified for use, the uncertified side may perform satisfactorily in the event the certified side is damaged or worn and a replacement cannot be obtained immediately.

NOTE

When the letters on the edge of the disk are upside down, the certified side of the disk is facing the heads.

- (1) *Tech-Met platter* – clean with alcohol or head cleaner; use Kim-wipes to clean and rinse thoroughly. *Do not scratch the surface.* Do not wash off the stamp near the inside edge which identifies the good side of the platter. Dry thoroughly.

- (2) *DMV platters* – use only Chevron 325 and DC4 lubricant. This cleaner has been designed to reduce the head sticking problem. It is extremely important to follow this procedure exactly; any deviation can cause disastrous consequences in the operation of the drive system.

- (a) Mount the disk on the disk buffing hub (supplied in RS Kit) with its certified side *up* (side facing heads).
- (b) *Put on plastic gloves* (supplied with cleaning kit).
- (c) Using a Kaydry wet with Chevron 325, swab the edge of the disk around the entire disk periphery. Dry with a fresh Kaydry.
- (d) Fold additional Kaydry towels into buffing pads by folding in half three times.
- (e) Apply a full dropper (1 ml) of Chevron 325 solvent to the disk at each of four locations, at a 6 inch radius, spaced 90° apart; buff to a haze-free surface.
- (f) Repeat step (e) three times to ensure complete cleanliness of the disk.

CAUTION

If the surface is not thoroughly cleaned and buffed dry, the heads may adhere to the surface enough to keep it from rotating. The disk must be disassembled again, cleaned and rebuffed completely dry.

- (g) Apply a full dropper of DC4 lubricant to each of four areas of the disk, at a 6-inch radius, spaced 90° apart.
 - (h) *Immediately* buff disk until polished free of haze. (Do not allow solution to dry.) Use the reverse surface of pad for final removal of haze over entire disk area.
 - (i) Wipe off any lint from both disk surfaces using a fresh Kaydry towel. It is now ready to be mounted back on the drive.
- o. Place the disk surface back on the motor hub, ensuring that the original surface is on the disk heads. (The opposite surface may be defective.) Replace the disk cap and the four Allen screws. When rotating the disk, ensure that it is rotated in a counter-clockwise manner. *Finger* tighten all screws.
 - p. The surface is now ready for the runout check (Figure 8). This will ensure that the surface is as flat as possible. A Fowler gauge can be found in the RS kit. Assemble the gauge on its stand and position on the deck close to the disk edge. While rotating the surface counter-clockwise, tighten each Allen screw slightly and alternately. Monitor the runout gauge while rotating the surface; ensure that the needle stays within 0.001 in., until each screw is reasonably tight. Remove the gauge and return it to the kit.
- q. Replace the cover *gently*; the hose inlet should be positioned to the opposite side of the cables.
 - r. Insert the Allen screws into the deck and tighten.
 - s. Replace the disk assembly in the cabinet; connect the hose to the rear of the cover. *Remember to remove the Kimwipe from the hose.* Insert each power wire as color coded. Insert each of the five cables in A1, A17, A18, A19, A20 (RS08).
 - t. The disk is now ready to power up. When ac power is applied to the cabinet and the toggle switch is placed in the ON position, the disk motor should have 115 Vac applied to it for 20 seconds, at which time, a relay will drop out and apply 60 Vac to the motor once it is up to speed.

CAUTION

If the motor does not turn at all, turn the switch OFF *immediately* or damage will result to the motor control.

This may occur because the surface was not thoroughly buffed dry and clean and the heads are adhering to the surface enough to keep it from rotating. In this case, the entire procedure must be repeated, i.e., the surface removed, cleaned, and buffed until thoroughly dry. Repeat steps a – t.

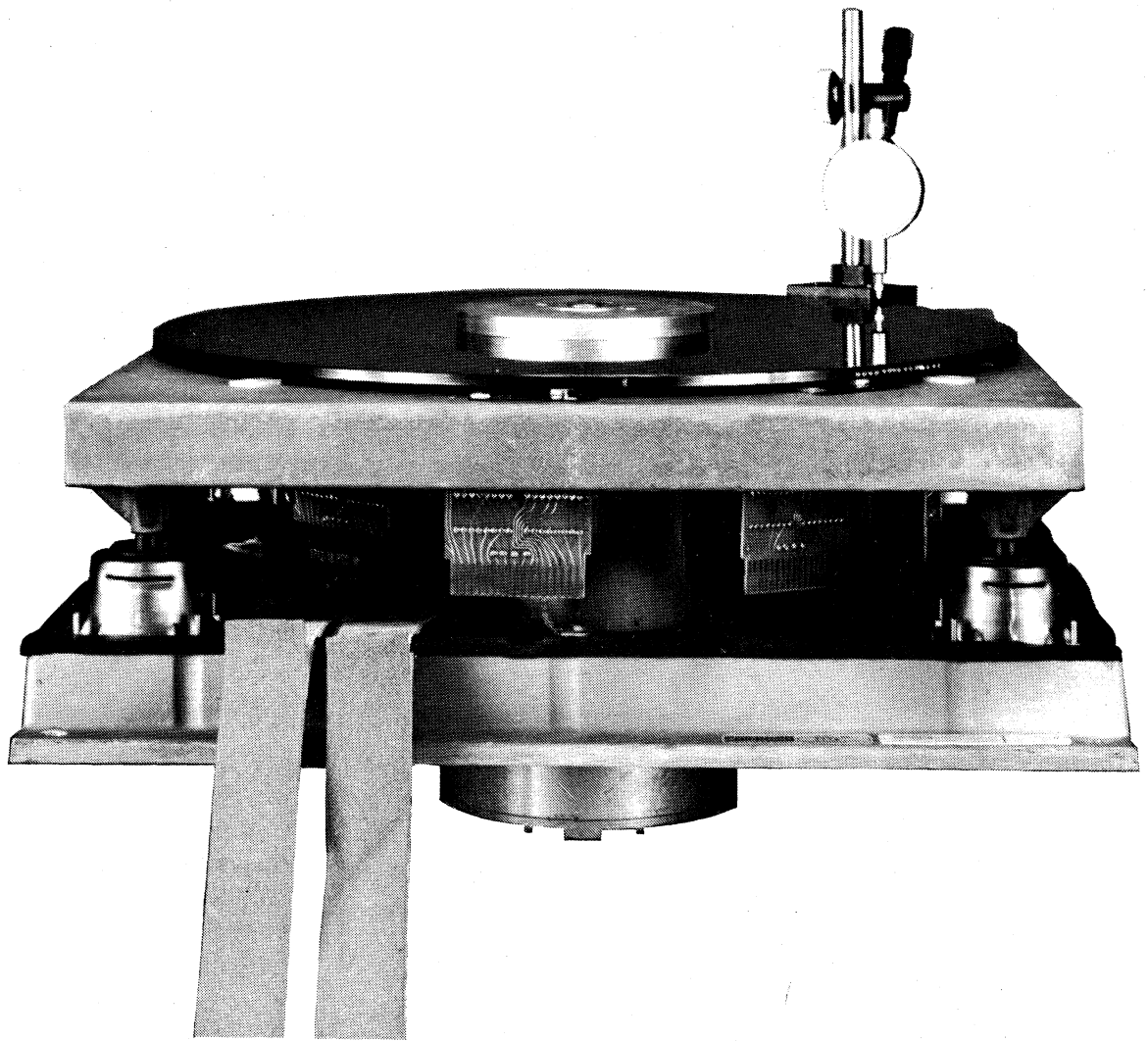

Figure 8 Placement of Fowler Gauge for Disk Runout Check



APPENDIX A

TIMING TRACK WRITER

A.1 PROCEDURE FOR TIMING TRACK CHECK

CAUTION

Timing tracks should be rewritten only when necessary. Repeated writing of the timing tracks may damage the disk drive timing track heads.

It may not be necessary to rewrite the timing tracks after removal and replacement of a surface as long as the surface has been returned to its original position, i.e., it has not been inverted.

1. With an oscilloscope, measure and record the average gain of the normal TTA, TTB, and TTC tracks over one revolution (Table 3).
2. Power the system down and invert the timing cable in slot A01 of the RS logic. Power the system up.
3. Measure and record the gain of the spare TTA, TTB, and TTC tracks.
4. After performing the head and surface cleaning procedure, measure the normal and spare tracks; compare the gains to the ones previously recorded. The new measurements may be greater than the old. If they are less by 10% or more, then it would be best to rewrite the tracks. If they are greater than 10%, adjust the amplifiers accordingly. Recheck the slice and adjust accordingly.

A.2 RS08 TIMING TRACK WRITER PROCEDURE

SETUP PROCEDURE

Connect the RS08-TA to the RS08 Disk Drive.

1. Remove dc power from the RS08 unit by turning the power off at the main computer console. The ac power to the RS08 must remain on.
2. Connect the RS08-TA dc power cable to the dc power bus on the rear of the RS08. The dc

power cable wires and dc power bus tabs are color-coded for easy identification.

Orange	+20 V
Red	+10 V
Blue	-15 V
Black	GND

NOTE

Ensure that disk drive power supply FIX/VAR switches are in the FIX position.

3. Remove the timing track cable from slot A01 of the RS08 electronics and insert it into the module connector on the RS08 Timing Track Writer (Figure A-1).
4. Apply dc power to the RS08 unit. DC power will also be applied to the timing track writer.

Set up scope as follows:

Vertical = 0.5 V/div (X10 probe)

Mode = Channel 1

Coupling = dc

A sweep time = 5 ms/div

Trigger = Line

A INTEN DURING B (B triggerable after delay)

Unlock knobs and set B delay to 0.1 ms/div

Connect the channel 1 scope probe to RS08-TA control panel test pin J1.

At the RS08-TA:

Set the NORMAL/MAINT switch to NORMAL

Set the REG/SPARE switch to REG

Set the WRITE ENABLE toggle switch to ON



Figure A-1 RS08 Timing Track Writer (RS08-TA)

WRITING TIMING TRACKS

1. Depress the WRITE pushbutton on the RS08-TA.

NOTE

The RS08-TA writes the timing tracks only once each time the WRITE pushbutton is depressed.

2. Observe timing track A on oscilloscope (Figure A-2). If timing track A amplitude is incorrect, refer to Table 3 for proper adjustment.

NOTE

If adjustment cannot be made, refer to Troubleshooting Flow Chart in the RS08 Timing Track Writer Maintenance Manual.

CAUTION

If at any time the scope display cannot be synchronized, i.e., the display moves across the scope screen, the RS08-TA is writing constantly. If this happens, the RS08-TA WRITE ENABLE toggle switch must be set to OFF *immediately* or the timing track heads may be damaged.

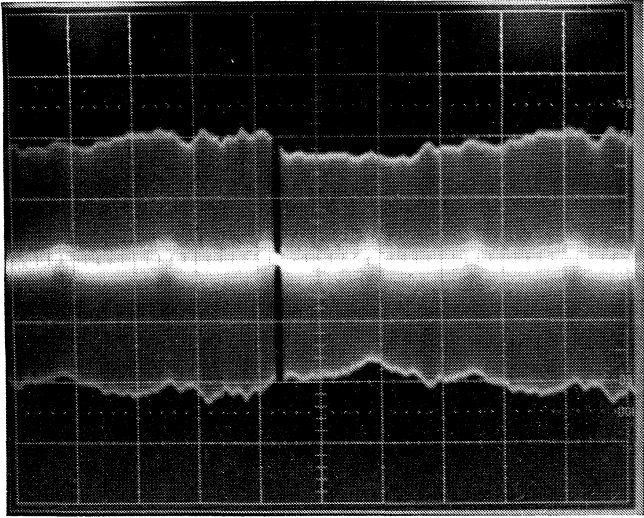

Figure A-2 Timing Track A Display

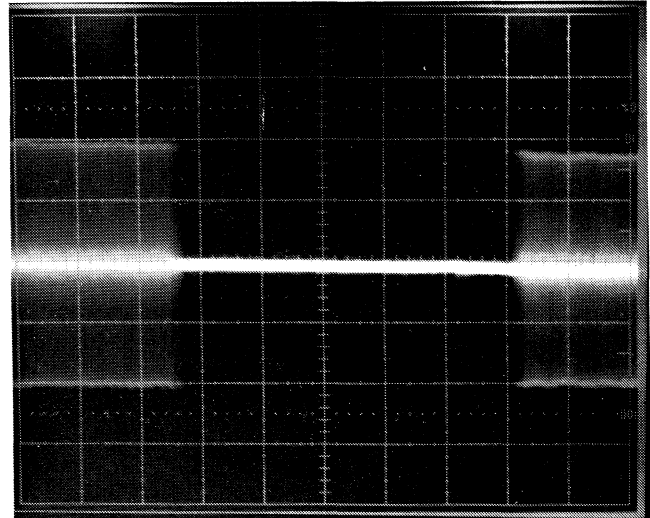

Figure A-3 550 μ s Gap Display

3. Depress RS08-TA WRITE pushbutton; observe that timing track A momentarily disappears and reappears each time the WRITE pushbutton is depressed; this is due to the erase operation performed by the RS08-TA just prior to rewriting timing tracks.
4. Move A INTEN DURING B to the gap (Figure A-2) and switch to B DELAYED.
5. Observe that the gap width is 550 (\pm 50) μ s (Figure A-3). If the gap meets specifications, proceed to step 8.
6. If the gap is too narrow, adjust RS08-TA control panel COARSE AND FINE knobs clockwise; repeat steps 3 through 5.
7. If the gap is too wide, adjust RS08-TA control panel COARSE AND FINE knobs counter-clockwise; repeat steps 3 through 5.
8. Switch oscilloscope to A INTEN and set the RS08-TA REG/SPARE switch to SPARE; observe the spare timing track.

NOTE

The spare timing track A waveform will probably have a different amplitude than the regular timing track A. However, do not readjust the gain of the G085 module.

9. Connect the channel 1 scope probe to RS08-TA control panel test pin J3 and set the RS08-TA REG/SPARE switch to REG; observe timing track B. Refer to Table 3 for specifications and adjustment.
10. Set the RS08-TA REG/SPARE switch to SPARE; observe the spare timing track B waveform.
11. Connect the channel 1 scope probe to RS08-TA control panel test pin J5 and set the RS08-TA REG/SPARE switch to REG; observe timing track C waveform.
12. Set the RS08-TA REG/SPARE switch to SPARE; observe the spare timing track C.
13. Set the RS08-TA WRITE ENABLE toggle switch to OFF.
14. Remove dc power from the RS08 Disk Drive by turning off the power at the main computer console.

CAUTION

DC power must be turned off at this point in the procedure even if the RS08-TA is to be used again; otherwise the RS08-TA will overheat and component failure may result.

15. Disconnect the RS08-TA dc power cable from the disk drive dc power bus.
16. Remove the timing track cable from the RS08-TA control panel connector and insert it into slot A01 of the RS08 Disk Drive electronics.
17. Turn dc power ON at the main computer console.

2. Connect the RS09-TA dc power cable to the dc power bus on the rear of the RS09. The dc power cable wires and dc power bus tabs are color-coded for easy identification.

Yellow	+20 V
Red	+10 V
Blue	-15 V
Black	GND

A.3 RS09 TIMING TRACK WRITER PROCEDURE

SETUP PROCEDURE

To connect the RS09-TA to the RS09 Disk Drive, proceed as follows:

1. Remove dc power from the RS09 Disk Drive unit. This can be accomplished by turning the power off at the main computer console. The ac power to the RS09 and the purge unit must remain on.
3. Remove the timing track cable from slot A01 of the RS09 electronics and insert it into the module connector on the RS09 Timing Track Writer (Figure A-4).
4. Apply dc power to the RS09 unit. DC power will also be applied to the timing track writer.
5. Set the RS09-TA RF SELECTOR knob to the proper disk controller (RF09, RF11, or RF15) and ac input line frequency (50 or 60 Hz).



Figure A-4 RS09 Timing Track Writer (RS09-TA)

WRITING TIMING TRACKS

To write timing tracks, proceed as follows:

NOTE

If faulty operation is detected at any point in the following procedure, refer to Chapter 5 of the *RS09 Timing Track Writer Maintenance Manual* and correct the fault before proceeding to the next step in the procedure.

CAUTION

Ensure that the NORMAL/MAINT toggle switch (Figure A-4) is set to the NORMAL position prior to setting the ON/OFF toggle switch to ON. Failure to do so may damage the disk drive timing track head.

1. Set the ON/OFF toggle switch to ON; the WRITE VOLTAGE indicator will illuminate.
2. Depress the PUSH TO WRITE pushbutton.
3. Perform the gain and slice adjustments as described in Table 3; observe the gain and slice display as shown in Figures 4 and 5.
4. Depress the PUSH TO WRITE pushbutton; observe the INCREASE, GAP OK, and DECREASE neons.

NOTE

The RS09-TA writes the timing tracks only once each time the PUSH TO WRITE pushbutton is depressed.

5. If the GAP OK neon illuminates, the timing tracks have been written properly; proceed to step 8.
6. If the INCREASE neon illuminates, turn the GAP ADJUST knob clockwise and repeat steps 4 and 5.
7. If the DECREASE neon illuminates, turn the GAP ADJUST knob counter-clockwise and repeat steps 4 and 5.
8. Set the ON/OFF toggle switch to the OFF position; observe that the WRITE VOLTAGE indicator extinguishes.
9. Remove dc power from the RS09 Disk Drive by turning off the power at the main computer console.
10. Disconnect the RS09-TA dc power cable from the disk drive dc power bus.
11. Remove the timing track cable from the RS09-TA control panel connector and insert it into slot A01 of the RS09 Disk Drive electronics.
12. Apply dc power to the disk drive.

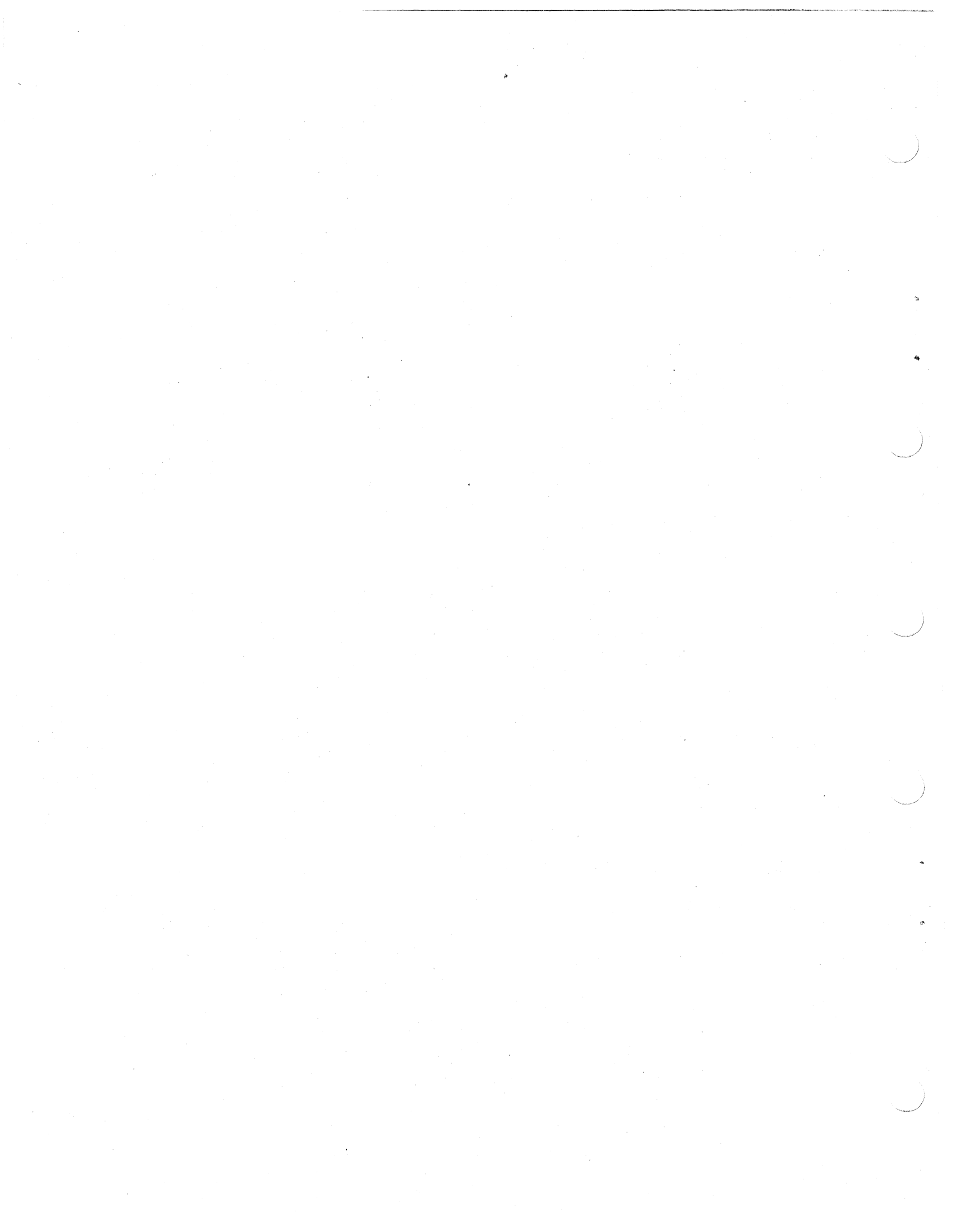

APPENDIX B MAINTENANCE PROGRAMS

B.1 RS08 MAINTENANCE PROGRAM

The following program allows a quick read or write to the disk, setting the desired track number into the switch register. Observe data with delayed sweep.

LOCATION	PROGRAM			
7600	7300	CLA,CLL		
	1300	TAD W.C.		
	3350	DCA 7750	/Set Word Count	
	1301	TAD C.A.		
	3351	DCA 7751	/Set Current Address	
	7604	LAS TRK#	/Load Track from Sw. Register	
	7010	RAR	/Check for Odd Track	
	7420	SNL	/Skip on Odd Track	
	7610	5215	JMP 7615	/Track is Even; JMP to 7615
		6643	DXAL	/Clear & Load EMA
7120		STL	/Set Link (to 1)	
7010		RAR	/Set ABSA Bit 0 to 1 for Odd TRK	
7615	5216	JMP +2	/JMP to ADD Rest of ABSA	
	6643	DXAL	/Clear & Load EMA	
7616	1302	TAD ABSA	/TAD Absolute Address	
	6603	DMAR;6605DMAW	/Read or Write	
	6622	DFSC	/Skip if Data Completion Flag Set	
	5220	JMP-1	/Wait for Data Completion Flag	
	5200	JMP BGN	/Jump Beginning	
	7700	7777	W.C.	/One Word
3777		C.A.		
N		ABSA		

1944

...

...

...

...

...

...

...

...

...

...

...

...

...

...

APPENDIX C

SPECIAL CALIBRATION REQUIREMENTS

C.1 REPLACING THE SHOES

To replace the shoes, perform the following steps:

1. Dismantle the assembly according to the instructions of Paragraph 8.0, step 3.
2. Locate the damaged shoe. If it is an inside shoe, the outside shoe must then be removed first. Remove the damaged shoe.
3. Examine the new shoe. If it must be cleaned, flush it with Methanol spray and blow it dry with MS220 Aeroduster. If any contaminants remain, saturate a cotton swab with Methanol and carefully wipe the head. Insert the new head.
4. To align the heads cut out a single layer of Kimwipe, approximately 4 in. X 4 in., and lay the Kimwipe over the motor hub to ensure a tight fit for the alignment disk found in the RS Kit.
5. Gently fit the alignment disk over the tissue and hub until it is well seated. Ensure that the heads are seated firmly against the disk.
6. The outermost head on every pad must be in line with its scribe line on the disk, as shown in Figure C-1.
7. Start with the outermost head on pad 0 and set it so that its inner edge is just touching the inside edge of the outside scribe line. Rotate the motor so that the radial line is over the next pad. Check that its outside head is lined up with the next track on the disk.
8. If any pad is out of line, loosen the three mounting screws on the bottom of the block and position it properly.

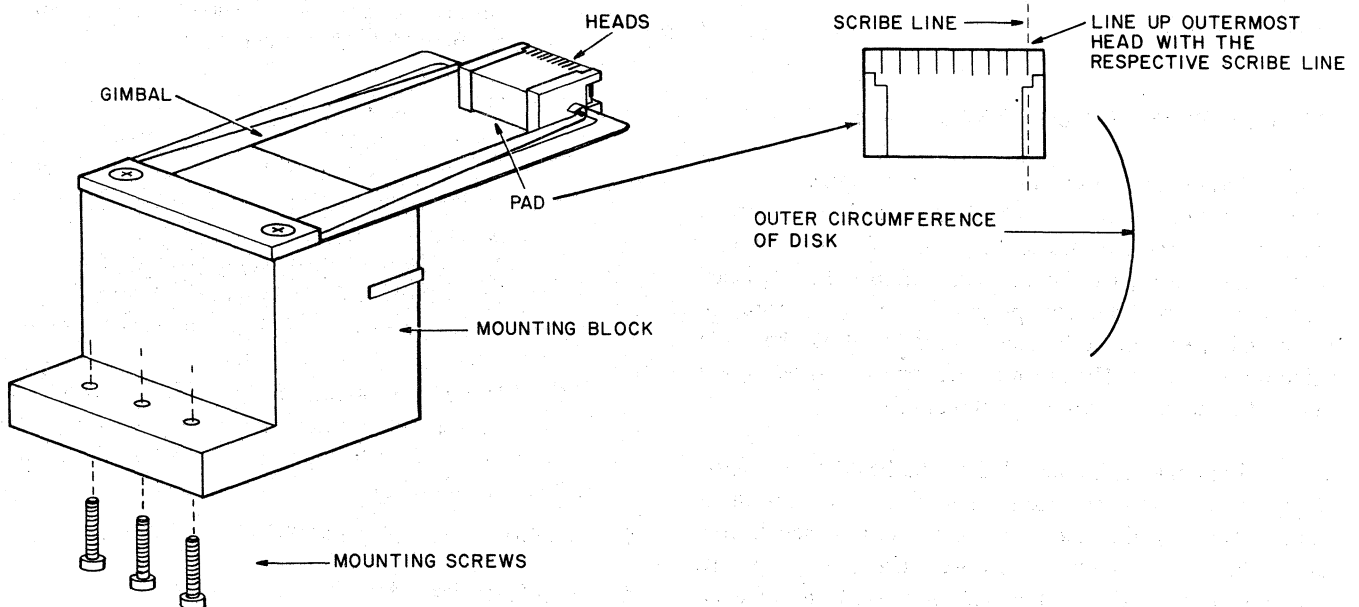

09-0411

Figure C-1 Aligning the Heads

C.2 MEASURING SURFACE MODULATION

If a new surface has been installed, the surface modulation should be checked. It is the result of variations in the properties of the surface around the disk. The test is done on the A track only. It is measured using the following procedure:

1. Connect a *calibrated* oscilloscope probe to pin A02T of the RS08 or RS09 (A Timing Track read amp).
2. Connect the oscilloscope ground strap to A02C.
3. Place the oscilloscope setting on dc.
4. Trigger the oscilloscope on LINE.
5. Set the time base to 5 ms/cm.
6. Measure V_{max} and V_{min} pp. Surface modulation = $\frac{V_{max} pp - V_{min} pp}{V_{max} pp + V_{min} pp} \times 100$

(Surface modulation should be less than 20%)

It is expected that the surface modulation falls off considerably when checking other tracks further inside from the A track. Data tracks with more than 13 percent deviation may be curtailing the performance of the disk drive considerably.

C.3 DETERMINING REFERENCE TRACK (RS09)

C.3.1 Determine Average Track for Each Matrix

When a new disk surface is installed or heads are replaced, the output of the data tracks (peak-to-peak amplitude) has to be read, recorded and compared, and the read amplifiers calibrated accordingly. This process involves measuring the mean voltage from each head and calculating the mean value for each shoe. The output variation of all shoes of any one matrix has to be within a certain limit.

The readings have to be recorded on the RS08M Data Sheet (Figure C-2) and the average track number (the track which has a reading equal to the mean of all shoes of each matrix) has to be posted on the disk cover. Use the appropriate program to select and read all 128 data tracks in sequence.

PDP-9, -15 Procedure

1. Use RS09/RF15 Alignment Program (MAINDEC-15-D5RA).

2. Load the alignment program and start at 200 with data switch 0 on a 1.
3. Calibrate the oscilloscope and probes. Use 10X probes only.
4. Select and read all 128 data tracks in sequence by entering the desired track number in data switches 11 through 17. The relationship between the selection lines at the RS09 and data switches 11 through 17 is shown below.

	Matrix	Head	Shoe
Data Switches	11	12, 13, 14	15, 16, 17
Track Address Register	0	1, 2, 3	4, 5, 6
RS09 Track Select Lines	T06	T05, T04, T03	T02, T01, T00

Continue with step 1 of the PDP-9, -11, -15 Procedure.

PDP-11 Procedure

1. Ensure that all AGC jumpers have been removed.
2. Write a 125252 pattern on the entire disk surface using the RF11 Data Test diagnostic or the new Multi-Disk diagnostic.
3. Use the Stamp portion of the diagnostic to adjust the lower track in each matrix (track 0 and track 100) to 6 V peak-to-peak. Location of the data read amplifiers in the RS11 logic panel is as follows:

Matrix 0 – G085 module in A05–B05
Matrix 1 – G085 module in A07–B07
4. Using the Stamp portion of the diagnostic, record the average peak-to-peak voltage for each head (0–177) on the RS08M Data Sheet (Figure C-2).

Continue with step 1 of the PDP-9, -11, -15 Procedure.

PDP-9, -11, -15 Procedure

1. Take the arithmetic mean peak-to-peak readings on each head. To read the tracks on matrix 0, probe should go on A05T; for matrix 1, on A07T.

RS08M DATA SHEET

O = Average Track
 * = Gain Added

Date: _____ By: _____ Disk Mfg. & #: 432 Head Tester #: none Motor Freq.: 50 Htz

Scope Type & #: 453 Preamp Type & #: 038518 Type Probes: P6047 X 10

X	AGC	Pos.	Grams Per Side	Signal Reading							A Mean	After Gain	% Deviation Shoe	Comments
				0	1	2	3	4	5	6				
1		TT												
2	*	0X0		6.2	6.4	5.9	6.0	6.6	6.8	6.7	6.6	6.35	7.62	
3		0X1		7.0	7.1	7.2	7.4	7.1	7.4	7.0	7.3	7.21	7.21	
4		0X2		6.2	6.0	7.8	7.2	7.0	7.5	7.92	6.5	7.46	7.46	
5		0X3		8.0	8.5	7.5	7.0	7.2	7.6	8.8	9.0	8.0	8.0	
6		0X4		7.28	7.9	7.5	7.7	7.6	7.4	8.0	7.3	7.65	7.64	
7		0X5		6.8	6.9	7.0	6.9	6.9	7.8	7.0	7.0	7.4	7.4	
8		0X6		7.0	7.2	8.3	7.1	7.3	7.1	7.2	7.0	7.65	7.65	
9		0X7		7.4	7.9	7.0	7.5	7.1	7.92	7.8	7.3	7.46	7.46	
10		1X0		6.0	5.8	5.9	5.6	6.2	5.6	5.7	5.7	5.8	5.8	
11		1X1		6.0	5.8	5.5	5.5	5.7	5.8	5.8	5.8	5.75	5.75	
12		1X2		5.8	5.4	5.6	5.6	5.8	4.9	5.1	5.9	5.4	5.4	
13	*	1X3		5.2	5.0	5.0	5.6	5.3	5.2	4.6	4.6	5.1	6.12	
14	*	1X4		5.2	4.8	5.1	4.8	4.8	4.6	4.6	5.2	4.9	5.88	
15	*	1X5		5.3	5.0	4.5	4.7	5.1	4.2	4.5	4.8	4.75	5.7	
16	*	1X6		5.0	4.6	5.0	4.8	5.2	5.2	4.2	5.0	4.85	5.82	
17	*	1X7		5.0	4.9	4.8	4.9	4.6	4.8	4.6	4.2	4.6	5.52	

DEC 3-(436)-1073-N669

Note: Each shoe must not have more than 20 percent deviation.

Figure C-2 RS08M Data Sheet

- From the readings taken, check the deviation for each shoe. Use one of two methods. The first one uses the formula below:

$$\frac{V_{\max} - V_{\min}}{V_{\max} + V_{\min}} \times 100 = \% \text{ deviation}$$

where: V_{\max} is the largest mean peak-to-peak voltage taken on that shoe; V_{\min} is the smallest mean peak-to-peak voltage taken on that shoe.

This value should be less than 13 for any shoe. If it is more than 13, the shoe should be replaced.

The second method takes V_{\min} and adds 30 percent of V_{\min} to itself.

The formula is: $(V_{\min} \times 0.3) + V_{\min}$.

The sum must be greater than V_{\max} . If the sum is less than V_{\max} , it means that the difference between V_{\max} and V_{\min} is greater than 30 percent of V_{\min} ; in this case, the shoe has to be replaced.

C.3.2 Adjusting the Data Read Amplifiers

Prior to the introduction of Revision F G085 Read Amplifiers, the percentage of deviation between the shoes of each matrix was calculated. Then, if it was necessary, the percentage of deviation was reduced by applying an AGC (Automatic Gain Control) jumper, for more gain, to the shoe with the lowest mean output. At this time, the data readers were calibrated by means of the gain adjustment.

Because it is practically impossible to see each individual excessively high or low amplitude bit out of more than 2000 words of data around each track, a new method which dynamically checks where gain jumpers are needed is described in this paragraph.

The use of different value gain and slice level adjustment potentiometers on Revision F G085 Read Amplifiers enables you to set gain for your average track to a nominal (6 V) level. This level does not need to be changed after the initial setting at the beginning of the calibration procedure. Instead, the slice level is calibrated down to a limit where noise is picked up as data and up to a limit where data bits are dropped. (This method is similar to a memory threshold adjustment.)

In case the track that is dropping bits with high slice is not on the same shoe which picked up bits when slice was low, an AGC jumper is installed (Table C-1) which will boost the gain of the failing shoe by 20 percent. Now the slice is turned down again to see that the AGC jumper is not causing other tracks of the jumpered shoe to pick up bits. If not, the process can be repeated and thus the operating range (margins) widened.

Table C-1
RS09, RS11 Jumpers to Increase Gain

Shoe No.	Pin		Matrix 0 Gain	Matrix 1 Gain
XX0	B17M	To Matrix 0 gain OR Matrix 1 gain	B20D	B20K
XX1	B17N		B20E	B20L
XX2	B17P		B18D	B18L
XX3	B17R		B18E	B18M
XX4	B17S		B18H	B18P
XX5	B17T		B18J	B18R
XX6	B17U			
XX7	B17V			

C.3.2.1 Using the RS09 Alignment Program to Adjust Data Read Amplifiers

NOTE

Make sure all G085 Read Amplifiers are of Revision F or newer.

- Load the RS09 Alignment Program (MAINDEC-15-D5RA).
- Start at 200 and select the desired disk unit using data switches 5 through 8.
- With data switch 0 up, select the average track (Paragraph C.3.1) for each matrix. Use data switches 11 through 17.
- Check for an average 6 V peak-to-peak signal amplitude. To check matrix 0, read from pin A05T; to check matrix 1, read from pin A07T. If necessary, adjust the gain (upper) potentiometer on the G085. (Follow the procedure as outlined in Table 3).

5. Set data switch 0 down (to 0) and data switch 4 up (to 1). To run the Data Pattern Test, select the desired switch setting for data switches 1, 2, 3, and 5 through 8. (Refer to switch option listing in the program writeup.)

The program now runs a random data test.

NOTE

Unless you are quite familiar with this procedure, select one matrix at a time, using switch 10 to delete (upper) matrix 1 and switch 9 to delete (lower) matrix 0.

6. Turn the slice level down slowly to the point where error printouts indicate which track is picking up bits.
7. Put data switch 4 down. The program now runs several patterns: 1) 252525; 2) 525252; 3) even word 0, odd words 777777; 4) even words 777777, odd words 0, and a random data pattern.
8. Back up the slice level to the point where you get at least two complete error-free passes of the program.
9. Record which track(s) failed on the Calibration Sheet (Figure C-3).
10. If this is the first time the slice level was turned down, select the track which has the most errors; if other than the first time, select the previously found REFERENCE track (refer to NOTE below). Use data switches 12 through 17 of the matrix (data switch 11) which is being checked. Set data switch 0 to 1 and read the slice level and record it on the RS Calibration Sheet.

NOTE

The track which fails when the slice level is adjusted down for the first time around will be recorded as the REFERENCE track. Only the REFERENCE track will be used for any and all slice level readings and adjustments during the remainder of the calibration procedure. Also, any future routine checks and troubleshooting should be done by referring to the REFERENCE track. This is because this track and shoe, failing with low slice, would have the maximum noise for zero data and therefore should never need an AGC jumper; also, both signal amplitude (gain) and slice level should not change.

11. If this is not the first pass through steps 6, 7, 8, 9, and 10, check if the shoe of the track which failed in step 6 has an AGC jumper. If it has, go to step 20; if not, continue with the next step.
12. Put data switch 0 down (to 0) and switch 4 up (to 1) and turn slice level up to the point where error printouts indicate failures.
13. Put data switch 4 down. The program now runs the patterns as described in step 7.
14. Back down the slice level to the point where you get at least two complete error-free passes of the program.
15. Record which track(s) failed on the Calibration Sheet.
16. Select REFERENCE track. Set data switch 0 to a 1. Read the slice level and record on the RS Calibration Sheet.

RS CALIBRATION SHEET

Customer Name: _____ System Serial No.: _____
 RS: _____ SN: _____ RS08M SN: _____ Platter Type: _____
 Engineers: _____ Date: _____

Use appropriate alignment program. For PDP-9 and PDP-15, use MAINDEC-15-D5RA. For PDP-11, use MAINDEC-11-DZRFC.

Surface Modulation on A Track: _____ %

MATRIX 0

Average Track # _____ . Set peak-to-peak amplitude to 6 volts.

*1 Reference Track# _____ ; Gain: _____ V; Final Slice Setting *2 _____ V;

Tracks Failing		AGC Jumper on Shoe #	Slice Voltage Near Failing Point With		D	FM
On Low Slice	On High Slice		Low Slice V_L	High Slice V_H		
*1						

$D = V_H - V_L$; MINIMUM $D = 1.3V$; MAXIMUM $V_L = 1.0V$; MINIMUM $FM = 0.4$

*2 FINAL SLICE SETTING $V_F = \frac{V_H + V_L}{2}$; $FM = \frac{V_H - V_L}{V_H + V_L}$

MATRIX 1

Average Track # _____ . Set peak-to-peak amplitude to 6 volts.

*1 Reference Track # _____ ; Gain: _____ V; Final Slice Setting *2 _____ V;

Tracks Failing		AGC Jumper On Shoe #	Slice Voltage Near Failing Point With		D	FM
On Low Slice	On High Slice		Low Slice V_L	High Slice V_H		
*1						

Figure C-3 RS Calibration Sheet

17. Calculate the difference between the slice voltages near the low and the high slice failing points. Also, calculate the figure of merit. Record both values in columns "D" and "FM", respectively.

NOTE

If the values for "D" and "FM" are exceptionally good, i.e., the values are well above the specified low limits, you may proceed to step 21.

18. If the track that failed in Step 12 is on a shoe which failed before, either on low slice or high slice, go to step 20; if it has not failed before, go to the next step.

19. Install an AGC jumper and go back to step 6.
20. If the "FM" and "D" is not acceptable (refer to specs on RS Calibration Sheet, Figure C-3), correct the source of the problem and start back at the beginning of the RS09 calibration.
21. Calculate final slice level (refer to formula on RS Calibration Sheet, Figure C-3), and set the REFERENCE track to the calculated value.
22. Record final slice level on RS Calibration Sheet and on the sticker on the disk cover.

RS08M HEAD DATA SHEET		
RS: _____	SN: _____	DATE: _____
TYPE OF DISK PLATTER _____		
SURFACE MODULATION _____ %		
MATRIX 0		
AVERAGE TRACK # _____ SET TO 6V p-p.		
R.T. (REFERENCE TRACK) # _____		
R.T. GAIN _____ V; FINAL SLICE SET: _____		
MATRIX 1		
AVERAGE TRACK # _____ SET TO 6V p-p.		
R.T. (REFERENCE TRACK) # _____		
R.T. GAIN _____ V; FINAL SLICE SET: _____		

Figure C-4 RS08M Head Data Sheet

C.3.2.2 Using the RF11 Multi-Disk Program to Adjust Data Read Amplifiers – In order to facilitate calibration procedures, the use of operational switch settings has been incorporated into the original Multi-Disk program. This new Multi-Disk program is MAINDEC-11-DZRFC. The switches used are listed in Table C-2.

**Table C-2
Control Switch Settings**

Switch	State	Function
15	Set	Enter non-restore mode.
	Reset	Save and restore disk information while testing random patterns.
14	Set	Ring bell on error.
	Reset	Report errors on Teletype.
13	Set	Omit random data pattern and operate with fixed pattern (125252).
	Reset	Select random data.
12	Set	Select disk from switches SR9 through SR7.
	Reset	Sequence through disks.
11	Set	Select matrix from switch SR6.
	Reset	Exercise both matrices.
10	Set	Select track number from switches SR5 through SR0.
	Reset	Sequence through tracks.

The Stamp Test portion of the Multi-Disk program allows the operator to statically select any track on any disk. This enables the user to read gain and slice information for that particular head. The starting address of this test is location 210. The following switches are functional during the test:

Switches	Function
15 through 10	Not used
9, 8, and 7	Disk selection
6 through 0	Track selection

1. Run the Multi-Disk program in the random pattern, non-save mode of operation.
2. Carefully reduce the slice voltage on Matrix 0 and find the one low failing point. Increase slice voltage slightly until the program just runs error free. This test determines the 0 noise level. Record the number of the track that caused an error on the Calibration Sheet (Figure C-3) as the REFERENCE track.
3. Stop the random pattern program. Write a 125252 pattern and restart the Stamp test, selecting the reference track (the track found on the first pass in step 2 of this procedure). Record the low slice voltage level (V_L). On the first pass, the gain of the reference track should also be measured and recorded.
4. Restart the Multi-Disk program in the random pattern, non-save mode. Carefully increase the slice voltage and find the one high failing point. Reduce the slice voltage slightly until the program just runs error free. This test finds the 1 noise level.
5. Stop the random pattern program. Write a 125252 pattern and restart the Stamp test, selecting the reference track. Record the high failing track number and the high slice voltage (V_H).
6. Install an AGC jumper on the shoe containing the high failing track found in step 4. Record the jumper location (refer to Table C-1).
7. Calculate and record the Figure of Merit (FM) and the signal region (D), where:

$$FM = \frac{V_H - V_L}{V_H + V_L}$$

$$\text{and } D = V_H - V_L.$$

8. Repeat steps 1 through 7 until D is maximized. If D decreases significantly on a subsequent pass, remove the previous AGC jumper.

- The following values are the *minimum* acceptable results when calibrating the RS11. In actual practice, a disk with a good surface and well matched shoes surpasses these values by a wide margin. Because the goal of the calibration procedure is to maximize disk performance, every effort should be made to exceed these values.

Minimum FM = 0.4
 Minimum D = 1.3 V
 Maximum V_L = 1.0 V

- When D has been maximized, calculate and record the final slice voltage setting (V_F) using the data from the last pass where

$$V_F = \frac{V_H + V_L}{2}$$

Set the slice voltage to V_F on the reference track and record this value plus the reference track gain on the tag attached to the disk enclosure.

- Repeat the entire procedure for Matrix 1.

C.4 RS08 DATA TRACK GAIN (AGC EQUALIZATION)

The following is the proper procedure for Data Track Gain adjustment on the RS08:

- To successfully perform Data Track Gain adjustments, the RF08/RS08 system must be capable of writing all 1s on every data track; it must also be capable of reading, with errors permissible, on each data track.
- Write all 1s on all data tracks, using Disk Data diagnostic subroutine SA201.
- Set the oscilloscope vertical amplitude to 0.2 V/cm, set the sweep speed to 2 ms/cm triggered from ON-LINE, and connect the channel 1 probe to A12T and ground it to A12-S.

- Using Disk Data Track selection subroutine SA0265, adjust the G085 gain potentiometer in location A12 to obtain a reading of 7 V peak-to-peak on data track 000.
- Using Disk Data Track selection subroutine SA0265, measure and record the amplitudes of all data tracks on the RS08 Amplitude Sheet. Observe the results and equalize the data tracks as required using AGC jumpers (Table C-3).
- After equalizing the data tracks, set the G085 gain so that the highest amplitude track is 12 V peak-to-peak.

NOTE

Average data track amplitude must never exceed 12 V peak-to-peak or go below 4.5 V peak-to-peak. If these conditions are not met, adjust the gain of the G085 module, located in slot A12, to compensate for the difference, then repeat step 5.

If compensation is not met, reject the unit and change the read/write head to low or high TK.

Table C-3
 RS08 Jumpers to Increase Gain

Track No.	From Pin	Track No.	From Pin	To AGC Input*
00	A29M	10	A30M	A31D
01	A29N	11	A30N	A31E
02	A29P	12	A30P	A32H
03	A29R	13	A30R	A32J
04	A29S	14	A30S	A32L
05	A29T	15	A30T	A32M
06	A29U	16	A30U	A32P
07	A29V	17	A30V	A32R
				A32T
				A32U

*Use only one jumper to an input.

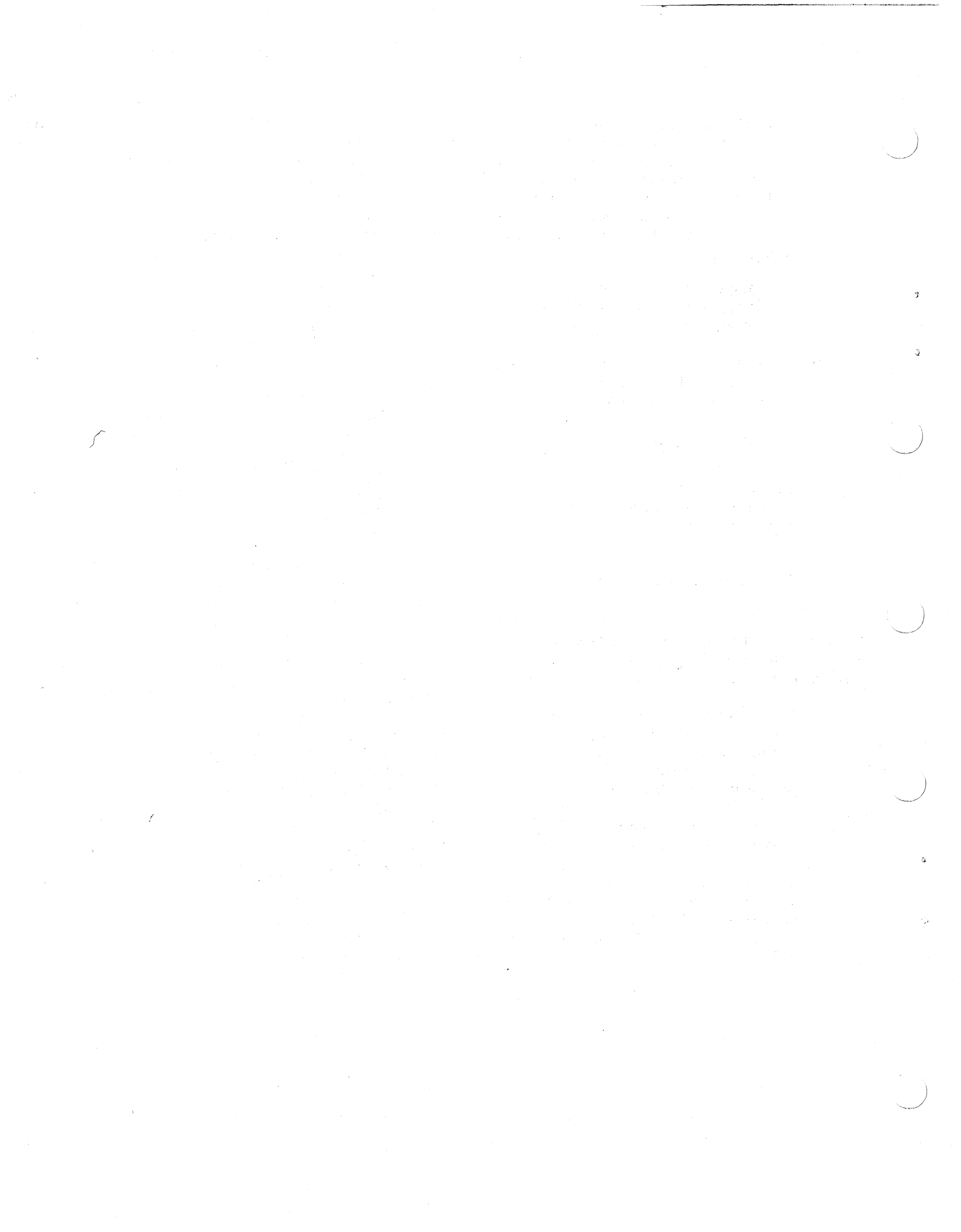

Your comments and suggestions will help us in our continuous effort to improve the quality and usefulness of our publications.

What is your general reaction to this manual? In your judgment is it complete, accurate, well organized, well written, etc.? Is it easy to use? _____

What features are most useful? _____

What faults do you find with the manual? _____

Does this manual satisfy the need you think it was intended to satisfy? _____

Does it satisfy *your* needs? _____

Why? _____

Would you please indicate any factual errors you have found. _____

Please describe your position. _____

Name _____

Organization _____

Street _____

Department _____

City _____

State _____

Zip or Country _____

Fold Here

Do Not Tear - Fold Here and Staple

FIRST CLASS
PERMIT NO. 33
MAYNARD, MASS.

BUSINESS REPLY MAIL
NO POSTAGE STAMP NECESSARY IF MAILED IN THE UNITED STATES

Postage will be paid by:

Digital Equipment Corporation
Technical Documentation Department
146 Main Street
Maynard, Massachusetts 01754



DIGITAL EQUIPMENT CORPORATION **digital** WORLDWIDE SALES AND SERVICE

MAIN OFFICE AND PLANT

Maynard, Massachusetts, U.S.A. 01754 • Telephone: From Metropolitan Boston: 646-8600 • Elsewhere: (617)-897-5111
TWX: 710-347-0212 Cable: DIGITAL MAYN Telex: 94-8457

DOMESTIC

NORTHEAST

REGIONAL OFFICE:

235 Wyman Street, Waltham, Mass. 02154
Telephone: (617)-890-0330/0310 Dataphone: 617-890-3012 or 3013

CONNECTICUT

Meriden
240 Pomeroy Ave., Meriden, Conn. 06540
Telephone: (203)-237-8441/7466 Dataphone: 203-237-8205
Fairfield
1275 Post Road, Fairfield, Conn. 06430
Telephone: (203)-255-5991

NEW YORK

Rochester
130 Allens Creek Road, Rochester, New York
Telephone: (716)-461-1700 Dataphone: 716-244-1680

Syracuse
6700 Thompson Road, Syracuse, New York 13211
Telephone: (315)-437-1593/7085 Dataphone: 315-454-4152

MASSACHUSETTS

Marlborough
One Iron Way
Marlborough, Mass. 01752
Telephone: (617)-481-7400 Telex: 710-347-0348

MID-ATLANTIC

REGIONAL OFFICE:

U.S. Route 1, Princeton, New Jersey 08540
Telephone: (609)-452-2940

FLORIDA

Orlando
Suite 130, 7001 Lake Ellenor Drive, Orlando, Florida 32809
Telephone: (305)-851-4450 Dataphone: 305-859-2360

GEORGIA

Atlanta
2815 Clearview Place, Suite 100
Atlanta, Georgia 03040
Telephone: (404)-451-7411 Dataphone: 305-859-2360

NORTH CAROLINA

Durham/Chapel Hill
Executive Park
3700 Chapel Hill Blvd.
Durham, North Carolina 27707
Telephone: (919)-489-3347 Dataphone: 919-489-7832

NEW JERSEY

Fairfield
253 Passaic Ave., Fairfield, New Jersey 07006
Telephone: (201)-227-9280 Dataphone: 201-227-9280
Metuchen
95 Main Street, Metuchen, New Jersey 08840
Telephone: (201)-549-4100/2000 Dataphone: 201-548-0144

MID-ATLANTIC (cont.)

Princeton
U.S. Route 1, Princeton, New Jersey 08540
Telephone: (609)-452-2940 Dataphone: 609-452-2940

NEW YORK

Long Island
1 Huntington Quadrangle
Suite 1507 Huntington Station, New York 11746
Telephone: (516)-694-4131 (212)-895-8095
Dataphone: 516-293-5693

Manhattan
810 7th Ave., 22nd Floor
New York, N.Y. 10019
Telephone: (212)-582-1300

PENNSYLVANIA

Philadelphia
Digital Hall
1740 Walton Road, Blue Bell, Pennsylvania 19422
Telephone: (215)-825-4200

TENNESSEE

Knoxville
6311 Kingston Pike, Suite 21E
Knoxville, Tennessee 37919
Telephone: (615)-588-6571 Dataphone: 615-584-0571

WASHINGTON D.C.

Lanham 30 Office Building
4900 Princess Garden Parkway, Lanham, Maryland
Telephone: (301)-459-7900 Dataphone: 301-459-7900 X53

CENTRAL

REGIONAL OFFICE:

1850 Frontage Road, Northbrook, Illinois 60062
Telephone: (312)-498-2500 Dataphone: 312-498-2500 Ex. 78

INDIANA

Indianapolis
21 Beachway Drive, Suite G
Indianapolis, Indiana 46224
Telephone: (317)-243-8341 Dataphone: 317-247-1212

ILLINOIS

Chicago
1850 Frontage Road
Northbrook, Illinois 60062 Dataphone: 312-498-2500

LOUISIANA

New Orleans
3100 Ridgelake Drive, Suite 108
Metairie, Louisiana 70002
Telephone: (504)-837-0257 Dataphone: 504-833-2800

CENTRAL (cont.)

MICHIGAN

Ann Arbor
230 Huron View Boulevard, Ann Arbor, Michigan 48103
Telephone: (313)-761-1150 Dataphone: 313-769-9883
Detroit
23777 Greenfield Road
Suite 189
Southfield, Michigan 48075 Dataphone: 313-557-3063

MINNESOTA

Minneapolis
8030 Cedar Ave. South, Minneapolis, Minnesota 55420
Telephone: (612)-854-6562-3-4-5 Dataphone: 612-854-1410

MISSOURI

Kansas City
12401 East 43rd Street, Independence, Missouri 64055
Telephone: (816)-252-2300 Dataphone: 816-461-3100
St. Louis
Suite 110, 115 Progress Parkway
Maryland Heights, Missouri 63043
Telephone: (314)-878-4310 Dataphone: 816-461-3100

OHIO

Cleveland
2500 Euclid Avenue, Euclid, Ohio 44117
Telephone: (216)-946-8484 Dataphone: 216-946-8477
Dayton
3101 Kettering Boulevard
Dayton, Ohio 45439
Telephone: (513)-294-3323 Dataphone: 513-298-4724

OKLAHOMA

Tulsa
3140 S. Winston
Winston Sq. Bldg., Suite 4, Tulsa, Oklahoma 74135
Telephone: (918)-749-4476 Dataphone: 918-749-2714

PENNSYLVANIA

Pittsburgh
400 Penn. Center Boulevard, Pittsburgh, Pennsylvania 15235
Telephone: (412)-243-9404 Dataphone: 412-824-9730

TEXAS

Dallas
Plaza North, Suite 513
2880 LBJ Freeway, Dallas, Texas 75234
Telephone: (214)-620-2051 Dataphone: 214-620-2061

HOUSTON

6656 Hornwood Drive
Monterey Park, Houston, Texas 77036
Telephone: (713)-777-3471 Dataphone: 713-777-1071

WISCONSIN

Milwaukee
8531 West Capitol Drive, Milwaukee, Wisconsin 53222
Telephone: (414)-463-9110 Dataphone: 414-463-9115

WEST

REGIONAL OFFICE:

310 Soquel Way, Sunnyvale, California 94086
Telephone: (408)-735-9200 Dataphone: 408-735-1820

ARIZONA

Phoenix
4358 East Broadway Road, Phoenix, Arizona 85040
Telephone: (602)-268-3488 Dataphone: 602-268-7371

CALIFORNIA

Santa Ana
2110 S. Anne Street, Santa Ana, California 92704
Telephone: (714)-979-2460 Dataphone: 714-979-6850
San Diego
6154 Mission Gorge Road
Suite 110, San Diego, California
Telephone: (714)-280-7880/7970 Dataphone: 714-280-7825

San Francisco
1400 Terra Bella, Mountain View, California 94040
Telephone: (415)-964-6200 Dataphone: 415-964-1436

Oakland

7850 Edgewater Drive, Oakland, California 94621
Telephone: (415)-635-5453/7830 Dataphone: 415-562-2160

West Los Angeles

1510 Cotner Avenue, Los Angeles, California 90025
Telephone: (213)-479-3791/4318 Dataphone: 213-478-5626

COLORADO

7901 E. Bellevue Avenue
Suite 5, Englewood, Colorado 80110
Telephone: (303)-770-6150 Dataphone: 303-770-6628

NEW MEXICO

Albuquerque
10200 Manual N.E., Albuquerque, New Mexico 87112
Telephone: (505)-296-5411/5428 Dataphone: 505-294-2330

OREGON

Portland
Suite 168
5319 S.W. Westgate Drive, Portland, Oregon 97221
Telephone: (503)-297-3761/3765

UTAH

Salt Lake City
429 Lawn Dale Drive, Salt Lake City, Utah 84115
Telephone: (801)-487-4669 Dataphone: 801-467-0535

WASHINGTON

Bellevue
13401 N.E. Bellevue, Redmond Road, Suite 111
Bellevue, Washington 98005
Telephone: (206)-545-4058/455-5404 Dataphone: 206-747-3754

INTERNATIONAL

EUROPEAN HEADQUARTERS

Digital Equipment Corporation International Europe
81 route de l'Aire
1211 Geneva 26, Switzerland
Telephone: 42 79 50 Telex: 22 883

FRANCE

Digital Equipment France
Centre Silic — Cidex L 225
94533 Rungis, France
Telephone: 687-23-33 Telex: 26840

GRENOBLE

Digital Equipment France
Tour Mangin
16 Rue Du Gal Mangin
38100 Grenoble, France
Telephone: (76)-87-56-01 Telex: 212-32882

GERMAN FEDERAL REPUBLIC

Digital Equipment GmbH
MUNICH
8 Muenchen 13, Wallensteinplatz 2
Telephone: 0811-35031 Telex: 524-226

COLOGNE

5 Koeln 41, Aachener Strasse 311
Telephone: 0221-44-40-95 Telex: 888-2269
Telegram: Flip Chip Koeln

FRANKFURT

6078 Neu-Isenburg 2
Am Forstaus Gravebruch 5-7
Telephone: 06102-5526 Telex: 41-76-82

HANNOVER

3 Hannover, Podbielskistrasse 102
Telephone: 0511-69-70-95 Telex: 922-952

STUTTGART

D-7301 Kempt, Stuttgart
Marco-Polo-Strasse 1
Telephone: (0711)-45-50-65 Telex: 841-722-393

AUSTRIA

Digital Equipment Corporation Ges.m.b.H.
VIENNA
Mariahilferstrasse 136, 1150 Vienna 15, Austria
Telephone: 85 51 86

UNITED KINGDOM

Digital Equipment Co. Ltd.
U.K. HEADQUARTERS
Fountain House, Butts Centre
Reading RG1 7QN, England
Telephone: (0734) 583555 Telex: 8483278

BIRMINGHAM

Maney Buildings
29/31 Birmingham Rd., Sutton Coldfield
Warwickshire, England
Telephone: 021-355-5501 Telex: 337-060

BRISTOL

Fish Ponds Road, Fish Ponds
Bristol, England BS163HQ
Telephone: Bristol 651-431

EALING

Bilton House, Uxbridge Road, Ealing, London W.5
Telephone: 01-579-2334 Telex: 22371

EDINBURGH

Shiel House, Craigshill, Livingston,
West Lothian, Scotland
Telephone: 32705 Telex: 727113

LONDON

Management House
43 Parker St., Holborn, London
WC 2B 5PT, England
Telephone: 01-405-2614/4067 Telex: 27560

MANCHESTER

Arndale House
Chester Road, Stretford, Manchester M32 9BH
Telephone: (061)-865-7011 Telex: 668666

UNITED KINGDOM (cont.)

READING

Fountain House, Butts Centre
Reading RG1 7QN, England
Telephone: (0734)-583555 Telex: 8483278

NETHERLANDS

Digital Equipment N.V.
THE HAGUE
Sir Winston Churchillian 370
Rijswijk/The Hague, Netherlands
Telephone: 94 9220 Telex: 32533

BELGIUM

Digital Equipment N.V./S.A.
BRUSSELS
108 Rue D'Arlon
1040 Brussels, Belgium
Telephone: 02-139256 Telex: 25297

SWEDEN

Digital Equipment AB
STOCKHOLM
Englundavagen 7, 171 41 Solna, Sweden
Telephone: 98 13 90 Telex: 173 50
Cable: Digital Stockholm

NORWAY

Digital Equipment Corp. A/S
OSLO
Trondheimsveien 47
Oslo 5, Norway
Telephone: 02/68 34 40 Telex: 19079 DEC N

DENMARK

Digital Equipment Aktiebolag
COPENHAGEN
Hellerupvej 66
2900 Hellerup, Denmark

FINLAND

Digital Equipment AB
HELSINKI
Titismaantie 6
SF-00710 Helsinki 71
Telephone: (090) 370133
Cable: Digital Helsinki

SWITZERLAND

Digital Equipment Corporation S.A.
GENEVA
20, Quai Ernest Ansermet
Boite Postale 23, 1211 Geneva 8, Switzerland
Telephone No. 022 20 40 20 and 20 58 93 and 20 68 93
Telex: 28 92 01

ZURICH

Digital Equipment Corp. AG
Schaffhauserstr. 315
CH-8050 Zurich, Switzerland
Telephone: 01 46 41 91 Telex: 56059

ITALY

Digital Equipment S.p.A.
MILAN
Corso Garibaldi 49, 20121 Milano, Italy
Telephone: (02)-879-051/2/3/4/5 Telex: 843-33615

SPAIN

Digital Equipment Corporation Ltd.
MADRID
Atnio Ingenieros S.A., Enrique Larreta 12, Madrid 16
Telephone: 215 35 43 Telex: 27249

BARCELONA

Atnio Ingenieros S.A., Granduxer 76, Barcelona 6
Telephone: 221 44 66

ISRAEL

DEC Systems Computers Ltd.
TEL AVIV
Suite 103, Southern Habakuk Street
Tel Aviv, Israel
Telephone: (03) 443114/440783 Telex: 922-33-3163

CANADA

Digital Equipment of Canada, Ltd.
CANADIAN HEADQUARTERS
P.O. Box 11500
Ottawa, Ontario, Canada
K2H 8K8
Telephone: (613)-592-5111 TWX: 610-562-8732

TORONTO

2550 Goldenridge Road, Mississauga, Ontario
Telephone: (416)-270-9400 TWX: 610-492-7118

MONTREAL

9045 Cote De Liesse
Dorval, Quebec, Canada H9P 2M9
Telephone: (514)-636-9393 Telex: 610-422-4124

CALGARY/Edmonton

Suite 140, 6940 Fisher Road S.E.
Calgary, Alberta, Canada
Telephone: (403) 435-4881 TWX: 403-255-7408

VANCOUVER

Suite 202
644 S.W. Marine Dr., Vancouver
British Columbia, Canada V6P 5Y1
Telephone: (604)-325-3231 Telex: 610-929-2006

GENERAL INTERNATIONAL SALES

REGIONAL OFFICE

146 Main Street, Maynard, Massachusetts 01754
Telephone: (617) 897-5111
From Metropolitan Boston: 646-8600
TWX: 710-347-0217/0212
Cable: DIGITAL MAYN
Telex: 94-8457

AUSTRALIA

Digital Equipment Australia Pty. Ltd.
ADELAIDE
6 Montrose Avenue
Norwood, South Australia 5067
Telephone: (08)-42-1339 Telex: 790-82825

BRISBANE

133 Leichhardt Street
Spring Hill
Brisbane, Queensland, Australia 4000
Telephone: (072)-293088 Telex: 790-40616

CANBERRA

27 Collie St.
Fyshwick, A.C.T. 2609 Australia
Telephone: (062)-959073

MELBOURNE

60 Park Street, South Melbourne, Victoria 3205
Australia
Telephone: (03)-699-2888 Telex: 790-30700

PERTH

643 Murray Street
West Perth, Western Australia 6005
Telephone: (092)-21 4993 Telex: 790-92140

SYDNEY

P.O. Box 491, Crows Nest
N.S.W. Australia 2065
Telephone: (02)-439-2563 Telex: 790-20740

NEW ZEALAND

Digital Equipment Corporation Ltd.
AUCKLAND
Hilton House, 430 Queen Street, Box 2471
Auckland, New Zealand
Telephone: 75533

JAPAN

Digital Equipment Corporation International
Kowa Building No. 16 — Annex, First Floor
9-20 Akasaka 1-Chome
Minato-Ku, Tokyo 107, Japan
Telephone: 588-2771 Telex: J-26428
Rikei Trading Co., Ltd. (sales only)
Kozato-Kaikun Bldg.
No. 18-14 Nishishimbashi 1-Chome
Minato-Ku, Tokyo, Japan
Telephone: 5915246 Telex: 781-4208

PUERTO RICO

Digital Equipment Corporation De Puerto Rico
407 del Parque Street
Santurce, Puerto Rico 00912
Telephone: (809)-723-8068/67 Telex: 385-9056

ARGENTINA

BUENOS AIRES
Coasin S.A.
Virrey del Pino, 4071, Buenos Aires
Telephone: 52-3185 Telex: 012-2284

BRAZIL

RIO DE JANEIRO — GB
Ambriex S.A.
Rua Ceará, 104, 2 e 3 andares ZC - 29
Rio De Janeiro — GB
Telephone: 264-7406/0461/7625

SÃO PAULO

Ambriex S.A.
Rua Tupi, 535
Sao Paulo — SP
Telephone: 52-7806/1870, 51-0912

PORTO ALEGRE — RS

Rua Coronel Vicente 421/101
Porto Alegre — RS
Telephone: 24-7411

CHILE

SANTIAGO
Coasin Chile Ltda. (sales only)
Casilla 14588, Correo 15,
Telephone: 396713 Cable: COACHIL

INDIA

BOMBAY
Hinditron Computers Pvt. Ltd.
69/A, L. Jagmohandas Marg.
Bombay-6 (WB) India
Telephone: 38-1615 36-5344 Telex: 0