

9000A-6502

Interface Pod

Instruction Manual

P/N 613760
June 1981

©1981, John Fluke Mfg. Co., Inc., all rights reserved Litho in U.S.A.



Table of Contents

SECTION	TITLE	PAGE
1	INTRODUCTION	1-1
	1-1. PURPOSE OF INTERFACE POD	1-1
	1-2. DESCRIPTION OF INTERFACE POD	1-1
	1-3. SPECIFICATIONS	1-2
2	INSTALLATION	2-1
	2-1. GENERAL	2-1
	2-2. MAKING CONNECTIONS	2-1
	2-3. POWER CONNECTIONS	2-2
3	MICROPROCESSOR DATA	3-1
	3-1. INTRODUCTION	3-1
	3-2. 6502 SIGNALS	3-1
	3-3. STATUS/CONTROL LINES AND ADDRESS SPACE ASSIGNMENT	3-1
	3-4. Introduction	3-1
	3-5. Bit Assignment - Status Lines	3-3
	3-6. User - Writeable Control Lines	3-4
	3-7. Bit Assignment - Control Lines	3-4
	3-8. Address Space Assignment	3-4
	3-9. FORCING AND INTERRUPT LINES	3-5
	3-10. LINES ENABLED DURING TROUBLESHOOTER SETUP	3-6
	3-11. MARGINAL UUT PROBLEMS	3-6
	3-12. Introduction	3-6
	3-13. UUT Operating Speed and Memory Access	3-6
	3-14. UUT Noise Levels	3-6
	3-15. Bus Loading	3-6
	3-16. Clock Loading	3-6
	3-17. POD DRIVE CAPABILITY	3-7
	3-18. POWER FAILURE DETECTION LIMITS	3-7

TABLE OF CONTENTS, *continued*

SECTION	TITLE	PAGE
4	THEORY OF OPERATION	4-1
	4-1. INTRODUCTION	4-1
	4-2. GENERAL POD OPERATION	4-1
	4-3. Processor Section	4-1
	4-4. UUT Interface Section	4-4
	4-5. Timing Section	4-4
	4-6. UUT Power Sensing	4-5
	4-7. DETAILED BLOCK DIAGRAM DESCRIPTION	4-5
	4-8. Processor Section	4-5
	4-9. UUT Interface Section - General	4-8
	4-10. UUT Interface Section - Data Lines	4-9
	4-11. UUT Interface Section - Address Lines	4-9
	4-12. UUT Interface Section - Status and Control Lines ...	4-12
	4-13. Timing Section	4-12
5	MAINTENANCE	5-1
	5-1. INTRODUCTION	5-1
	5-2. SELF TEST	5-1
	5-3. REPAIR PRECAUTIONS	5-2
	5-4. TROUBLESHOOTING	5-3
	5-5. Introduction	5-3
	5-6. Pod Defective or Inoperative?	5-6
	5-7. Selecting a UUT for Pod Testing	5-6
	5-8. Troubleshooting a Defective Pod	5-7
	5-13. Troubleshooting an Inoperative Pod	5-11
	5-14. DISASSEMBLY	5-15
6	LIST OF REPLACEABLE PARTS	6-1
	6-1. INTRODUCTION	6-1
	6-2. HOW TO OBTAIN PARTS	6-1
7	SCHEMATIC DIAGRAMS	7-1

List of Tables

TABLE	TITLE	PAGE
1-1.	6502 Interface Pod Specifications	1-4
3-1.	6502 Signals	3-1
3-2.	Status and Control Lines Bit Assignments	3-6
5-1.	Self Test Failure Codes	5-3
5-2.	Required Test Equipment	5-4
5-3.	6502 Pod Memory and I/O Addresses	5-13

List of Illustrations

FIGURE	TITLE	PAGE
1-1.	Relationship of Interface Pod	1-3
2-1.	Connection of Interface Pod to Troubleshooter	2-3
2-2.	Connection of Interface Pod to UUT	2-3
3-1.	6502 Pin Assignments	3-3
4-1.	General Block Diagram	4-2
4-2.	Detailed Block Diagram	4-6
4-3.	Handshaking Signals	4-10
4-4.	UUT ON Signal and Latch Times	4-11
5-1.	Interface PCB, Non-Component Side	5-5
5-2.	Troubleshooting a Defective Pod	5-8
5-3.	Troubleshooting an Inoperative Pod	5-13

Section 1

Introduction

1-1. PURPOSE OF INTERFACE POD

The purpose of the 9000A-6502 Interface Pod, hereafter referred to as the pod, is to interface any 9000 Series Micro System Troubleshooter to a piece of equipment employing a 6502 microprocessor.

The 9000 Series Micro System Troubleshooters are designed to service printed circuit boards, instruments and systems employing bus-oriented microprocessors. While the architecture of the troubleshooter main frame is general in nature and is designed to accommodate processors with up to 32 address lines and 32 data lines, the interface pod adapts the general purpose architecture of the 9000 Series to a specific microprocessor, or microprocessor family. The interface pod adapts the 9000 Series to microprocessor-specific functions such as pin layout, status/control functions, interrupt handling, timing, size of memory space, and size of I/O space.

1-2. DESCRIPTION OF INTERFACE POD

The pod consists of a pair of printed circuit board assemblies mounted within a small break-resistant case. A shielded 24-conductor cable connects the printed circuit boards to the troubleshooter; a ribbon cable and connector provide connection to the unit under test, hereafter referred to as the UUT.

Figure 1-1 shows the relationship of the pod to the troubleshooter and to the UUT. Connection from the pod to the troubleshooter is via a front-mounted 25-pin connector. Connection to the UUT is made by plugging the ribbon cable plug directly into the microprocessor socket. The UUT microprocessor socket gives the troubleshooter direct access to all system components which normally communicate with the microprocessor.

The pod contains a 6502 microprocessor and the supporting hardware and control software required to:

- Perform handshaking with the troubleshooter

6502

- Receive and execute commands from the troubleshooter
- Report UUT status to the troubleshooter
- Emulate the UUT microprocessor

The pod is powered by the troubleshooter, but is clocked by the UUT clock signal. Using the UUT clock signal allows the troubleshooter and pod to operate at the designed operating speed of the UUT.

Logic level detection circuits are provided on each line to the UUT. These circuits allow detection of bus shorts, stuck-high or stuck-low conditions, and any bus drive conflict (two or more drivers attempting to drive the same bus line).

Over-voltage protection circuits are also provided on each line to the UUT. These circuits guard against pod damage which could result from:

- Incorrectly inserting the ribbon cable plug in the UUT microprocessor socket.
- UUT faults which place potentially damaging voltages on the UUT microprocessor socket.

The over-voltage protection circuits guard against voltages of +12 to -7 volts on any one pin. Multiple faults, especially of long duration, may cause pod damage.

A power level sensing circuit constantly monitors the voltage level of the UUT power supply (+5V). If UUT power rises above or drops below an acceptable level, the pod notifies the troubleshooter of the power fail condition.

A self test socket provided on the pod enables the troubleshooter to check pod operation. The self test socket is a 40-pin zero-insertion force type connector. The ribbon cable plug must be connected to the self test socket during self test operation. The ribbon cable plug should also be inserted into this socket when the pod is not in use to provide protection for the plug.

1-3. SPECIFICATIONS

Specifications for the 9000A-6502 Interface Pod are listed in Table 1-1.

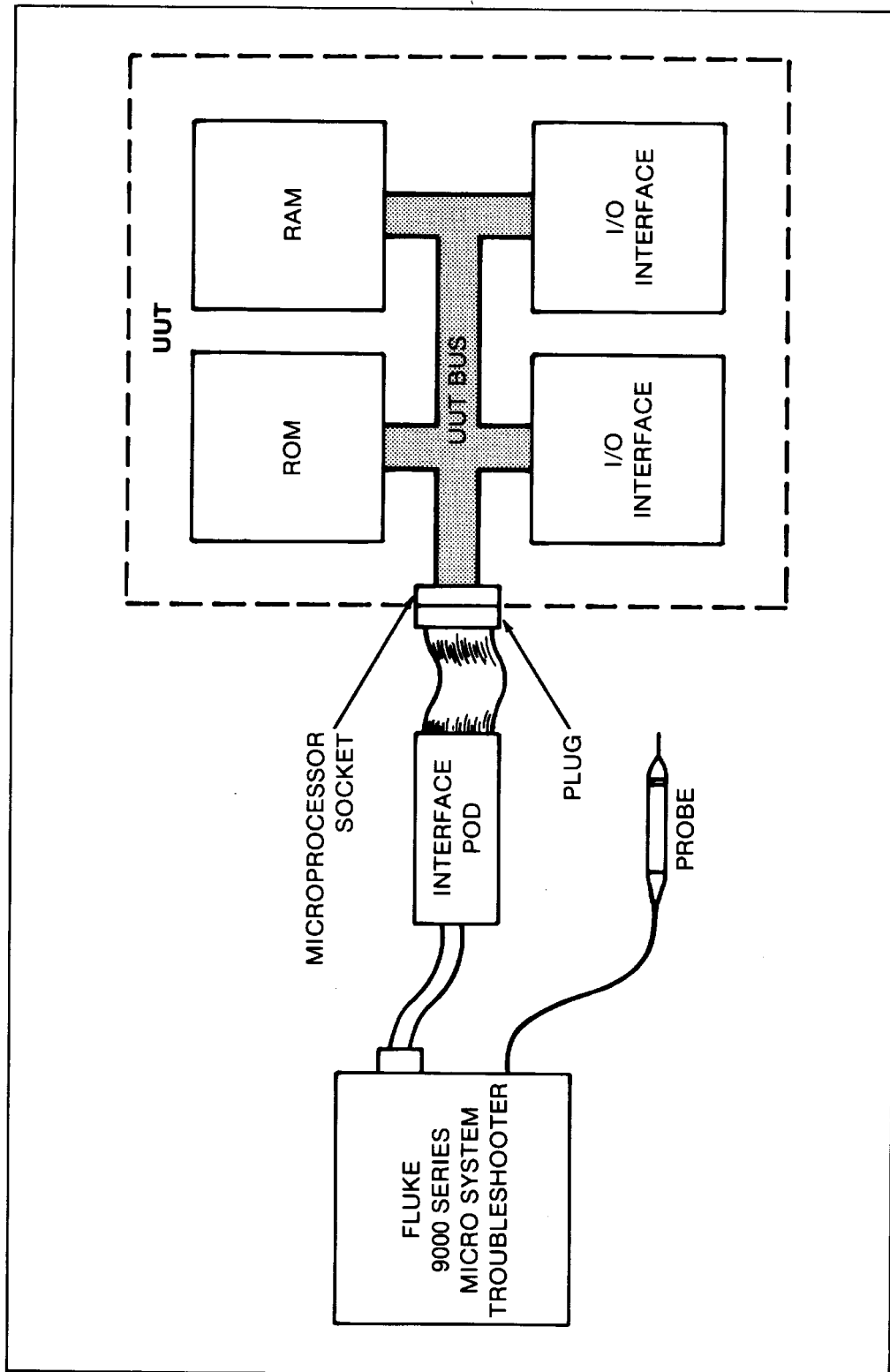

Figure 1-1. Relationship of Interface Pod

Table 1-1. 6502 Interface Pod Specifications

ELECTRICAL PERFORMANCE	
Power Dissipation	3.0 watts maximum
Electrical Protection	
CLOCK INPUTS	+0.3 to +7 volts may be applied between ground and any ribbon cable plug pin continuously as long as the pod is powered by the troubleshooter.
OTHER INPUTS	-7 to +12 volts may be applied between ground and any ribbon cable plug pin continuously as long as the pod is powered by the troubleshooter.
MICROPROCESSOR SIGNALS	
Input Low Voltage	0V min., +0.8V max.
Input High Voltage	+2.0V min., +5.0V max.
Output Low Voltage	+0.4V max. with $I_{ol} = 1.6 \text{ mA}$
Output High Voltage	+2.4V min. with $I_{oh} = -250 \mu\text{A}$
Tristate Output Leakage Current	
	$\pm 20 \mu\text{A}$
High Level Input Current	$20 \mu\text{A}$ typ. with $V_{ih} = +2.7\text{V}$
Low Level Input Current	
RDY, $\overline{\text{RESET}}$	$-400 \mu\text{A}$ max. with $V_{il} = +0.4\text{V}$
ALL OTHER INPUT LINES	$-20 \mu\text{A}$ typ. with $V_{il} = +0.4\text{V}$
TIMING CHARACTERISTICS	
Maximum Clock Frequency ..	2.0 MHz typ.
Added Delays to 6502 Signals	
LOW-TO-HIGH TRANSITIONS	20 ns typ.
HIGH-TO-LOW TRANSITIONS	24 ns typ.

Table 1-1. 6502 Interface Pod Specifications (cont)**UUT POWER DETECTION**

Detection of Low Vcc Fault ... $V_{cc} < +4.5V$ detected

Detection of High Vcc Fault .. $V_{bb} > -5.5V$ detected

GENERAL

Size 3.3 cm High x 10.2 cm Wide x 18.55 cm Deep
(1.3 in High x 4.0 in Wide x 7.4 in Deep)

Weight 0.68 kg (1.5 lbs)

Environment

STORAGE -40° to $+70^{\circ}C$, RH < 95%

OPERATING 0° to $+25^{\circ}C$, RH < 95%
 $+25^{\circ}$ to $+40^{\circ}C$, RH < 75%
 $+40^{\circ}$ to $+50^{\circ}C$, RH < 45%

Protection Class 3 Relates solely to insulation or grounding properties defined in IEC 348.

Section 2

Installation

2-1. GENERAL

Before a 9000 Series Micro System Troubleshooter can be used to perform any testing or fault isolation, it must be connected to the UUT. Connection is made by means of the pod, which is equipped with two cable assemblies, one shielded-type and one ribbon-type. The procedures for installing and connecting the pod are given in the following paragraphs.

2-2. MAKING CONNECTIONS

Before making any connections to the UUT, take note of the following precautions:

WARNING

TO PREVENT POSSIBLE HAZARDS TO THE OPERATOR OR DAMAGE TO THE UUT, DISCONNECT ALL HIGH-VOLTAGE POWER SUPPLIES, THERMAL ELEMENTS, MOTORS, OR MECHANICAL ACTUATORS WHICH ARE CONTROLLED OR PROGRAMMED BY THE UUT MICROPROCESSOR BEFORE CONNECTING POD.

- Be sure to install the ribbon cable plug correctly in the UUT microprocessor socket.
- The self test socket is intended for use with the ribbon cable plug only. Do not insert any microprocessor removed from a UUT under test, or any other device into this socket.

Connect the pod between the troubleshooter and the UUT as follows:

1. Remove power from the UUT. Remove power from the troubleshooter.

2. Using the round shielded cable, connect the pod to the troubleshooter as shown in Figure 2-1. Secure the connector using the sliding collar.
3. Apply power to the troubleshooter.
4. Perform a self-test of the pod as described in Section 5 of this manual.
5. With UUT power off, unplug the microprocessor from the UUT.
6. On the pod, turn the self test socket thumbwheel to release the plug from the self test socket.
7. Align the ribbon-cable with the microprocessor socket on the UUT so that the notched corner of the ribbon cable plug aligns with pin 1 of the socket. Insert the plug into the socket as shown in Figure 2-2.
8. Electrically reassemble the UUT. Use extender boards if necessary.

CAUTION

Ensure troubleshooter power is on before turning UUT power on in order to activate pod protection circuits.

9. Apply power to the troubleshooter and the UUT.

2-3. POWER CONNECTIONS

The pod receives +5 volts, -5 volts, and +12 volts from the 9000 Series Micro System Troubleshooter. No external power connections are required.

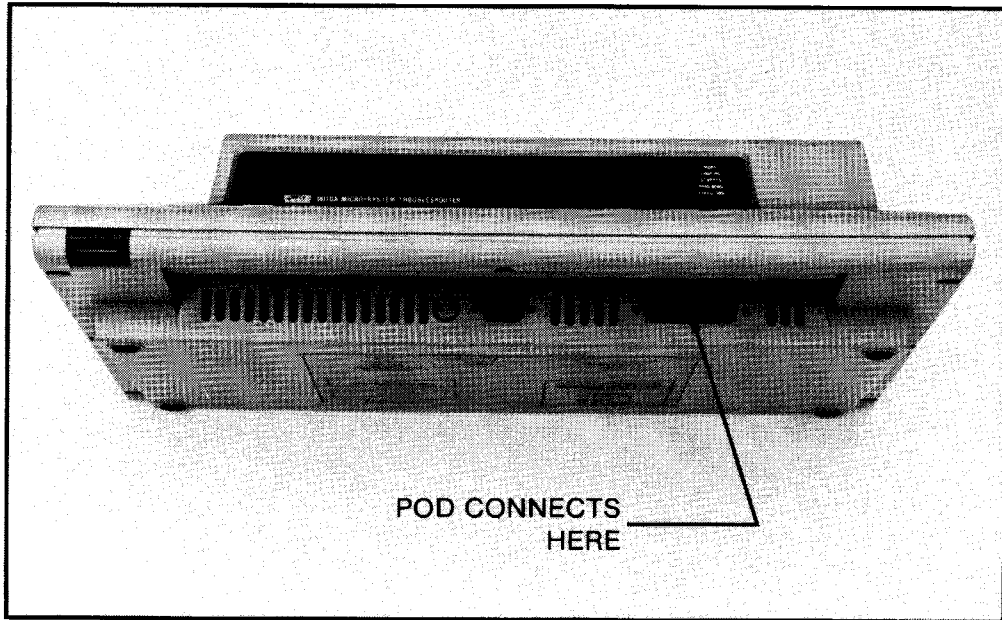

Figure 2-1. Connection of Interface Pod to Troubleshooter

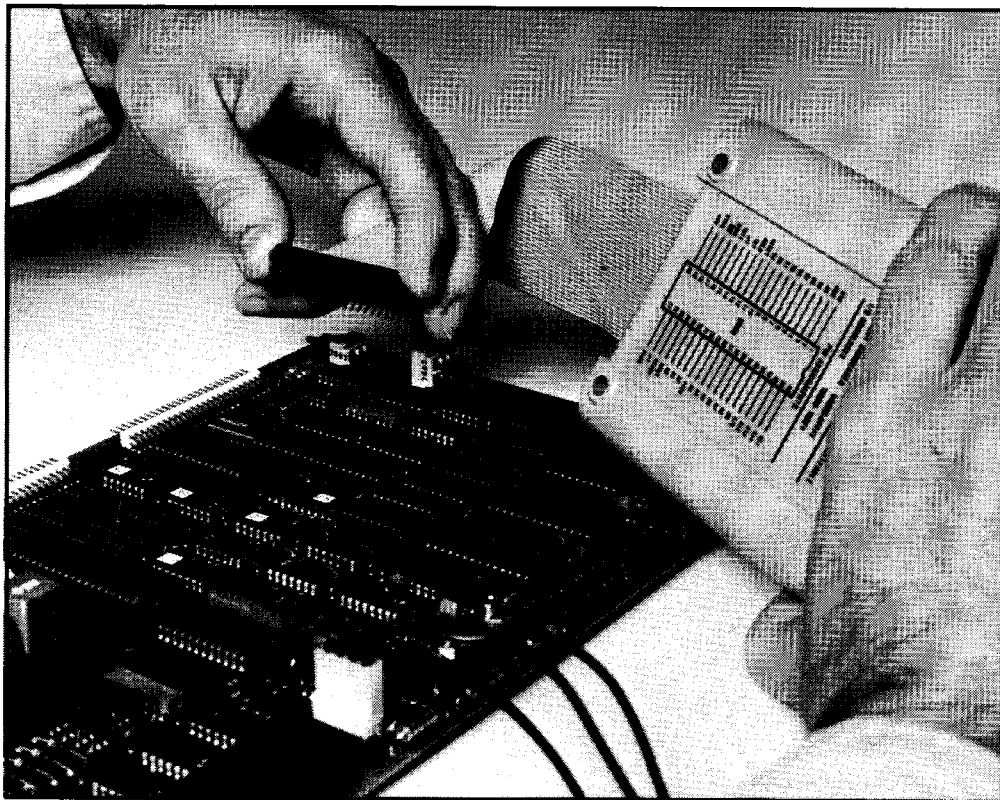

Figure 2-2. Connection of Interface Pod to UUT

Section 3

Microprocessor Data

3-1. INTRODUCTION

This section contains information which may be useful during operation of the troubleshooter. This information includes 6502 signal descriptions, explanations of status/control lines and address space assignment, the effects the pod may have on normal UUT operation, the pod capabilities and limitations, and pertinent pod characteristics.

3-2. 6502 SIGNALS

For reference, Table 3-1 lists all of the 6502 signals and provides a brief description of each. Figure 3-1 shows the pin assignment of 6502 signals.

3-3. STATUS/CONTROL LINES AND ADDRESS SPACE ASSIGNMENT

3-4. Introduction

The 9000 Series Micro System Troubleshooters are designed to accommodate bus-oriented processors having up to 32 address lines, 32 data lines, 16 status lines, and 8 control lines. The pod provides an interface between the general architecture of the 9000 Series and the specific requirements of the 6502 microprocessor. As part of this interface task, the pod makes specific assignments between the microprocessor lines and the 9000 Series troubleshooter. These assignments include:

- Bit number assignment of 6502 status lines
- User-writable control lines
- Bit number assignment of control lines
- Address space assignment
- Pin assignments

These assignments are described in the following paragraphs and are summarized for convenience on the pod decal.

Table 3-1. 6502 Signals

SIGNAL NAME	DESCRIPTION
Address Lines A0 - A15	The 16 address lines are designated A0 through A15, and are outputs only.
Data Lines D0 - D7	The 8 data lines are designated D0 through D7. The data lines are tri-state bi-directional lines, which are placed in the high impedance state during the first portion of each machine cycle.
RDY Line	The RDY line is an input which inserts the equivalent of a Wait machine cycle into the normal machine cycle sequence. The RDY line must go low during a high phase-one clock pulse in any machine cycle other than a write.
R/W Line	The R/W output is high to indicate that the 6502 is ready to read data from the data bus, and is pulled low when the 6502 outputs data onto the data bus. The standby state for the R/W line is high.
SYNC Line	The SYNC output is made high to identify the 6502 fetch cycle.
SO Line	The SO (set overflow) input is used to set the overflow bit of the status register to 1.
IRQ Line	The IRQ input is made low to request an interrupt. If interrupts have been enabled and the 6502 is not in the Halt state, the interrupt is acknowledged at the end of the instruction currently being executed.
NMI Line	The NMI input is a non-maskable interrupt (cannot be software disabled).
RESET Line	The RESET line is an input which requires a low level for eight machine cycles or longer. On the high-to-low transition R/W is made high. On the low-to-high transition, maskable interrupts are disabled and the program counter is set.

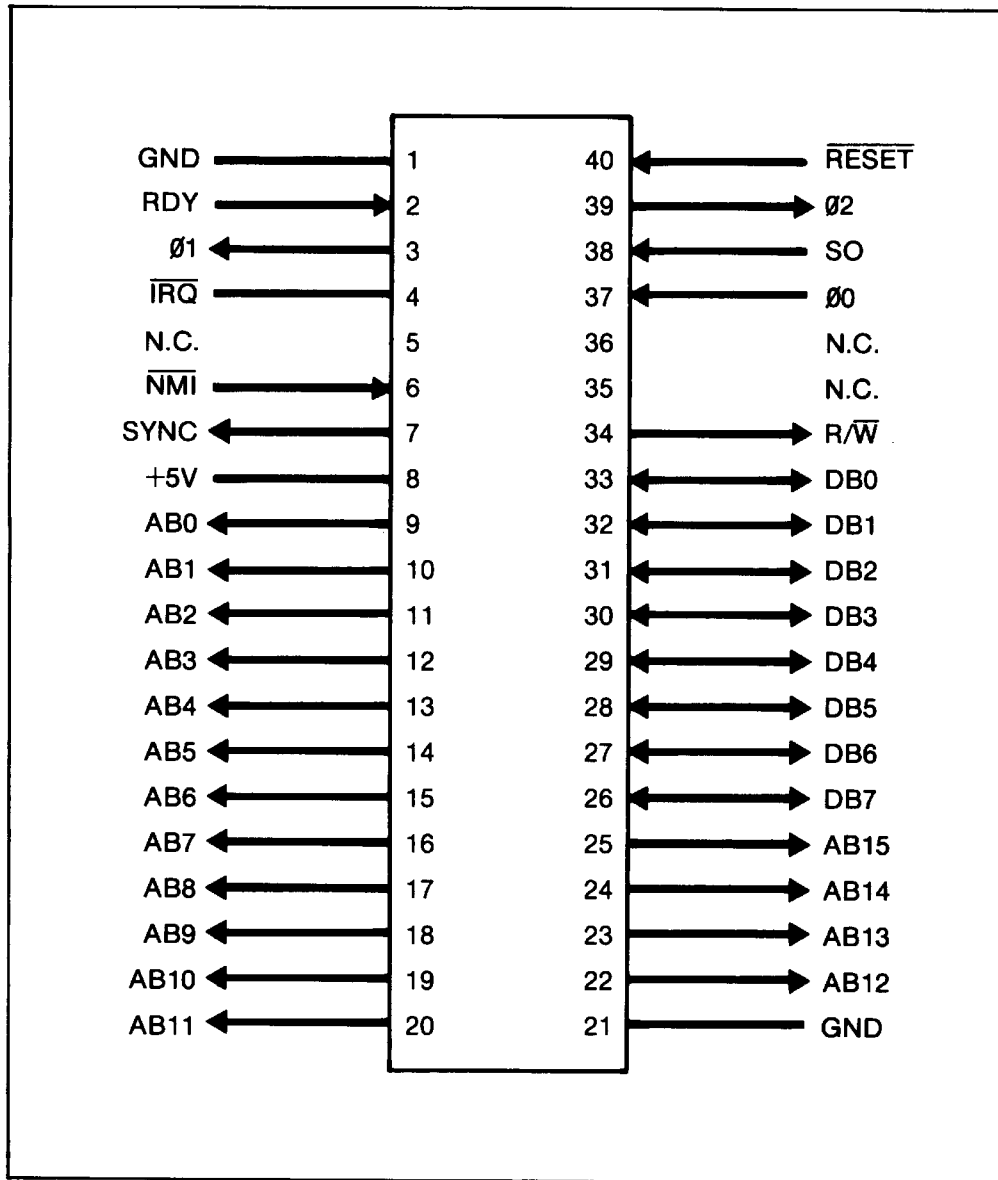

Figure 3-1. 6502 Pin Assignments

3-5. Bit Assignment - Status Lines

When a read status (READ @ STS) operation is performed, the troubleshooter displays the result in binary form, where a "1" indicates a logic high status line and a "0" indicates a logic low status line. To determine which characters of the display correspond to specific status lines, refer to Table 3-2. This table shows that each line is assigned a bit number. Bit number zero (RDY) appears at the far right of the display, while bit number 7 (POWER FAIL) appears at the far left side.

For example, if the RDY (bit number 0) and POWER FAIL (bit number 7) lines are low, and all other status lines are high, the troubleshooter would read *READ @ STS = 0001 1100 OK*. Bit numbers 0 (RDY) and 7 (POWER FAIL) are zero to indicate a logic low, while other meaningful bits are ones to indicate logic high. Bits 1, 5, and 6, which have no meaning as 6502 status lines, are always represented by zeros in the troubleshooter display message.

3-6. User-Writeable Control Lines

The 6502 has a control line which the troubleshooter can write to. This is the SYNC line. To write to the SYNC line, a WRITE CTL function is used as described in the paragraphs that follow. Note that writing to a control line only sets the line to the high or low state for approximately 20 microseconds; just long enough to verify that it can be driven.

3-7. Bit Assignment - Control Lines

There are two troubleshooting functions which require the entry of binary digits to identify user-writable control lines. These functions are write control (WRITE @ CTL) and data toggle control (DTOG @ CTL).

When performing or programming either of these two functions, the user is prompted for a binary number to identify the control line(s) to be written. Since the 6502 is equipped with only one user-writeable control line, SYNC, the binary number 1 or 0 is entered in response to the prompt. Entry of a 1 at bit number zero writes the SYNC line high, while entry of a 0 at bit number zero writes the SYNC line low.

If any control line cannot be driven, the troubleshooter responds with the message *CTRL ERR @ xxxxxxxx LOOP?*, where x equals a binary 1 if that line cannot be driven. For example, if in the write control operation, the SYNC line can be driven, the troubleshooter displays the message *CTRL ERR @ 00000001 LOOP?*. The binary 1 indicates that the SYNC line cannot be driven.

When performing a BUS TEST, and various other troubleshooter operations, the troubleshooter message *CTL ERR xxxxxxxx-LOOP?* can occur, where x represents a binary number that identifies which lines can or cannot be driven. A binary 0 represents the ability to drive a line, while a binary 1 represents the inability to drive a line. Table 3-2 lists all control lines and their respective bit numbers.

3-8. Address Space Assignment

The 6502 is capable of addressing up to 65,536 memory locations. The 9000 Series troubleshooter uses a consistent technique of addressing multiple memory and I/O locations.

In order to access one of the memory locations, the user provides a hexadecimal address in the range of 0000 to FFFF. For convenience, these assignments are also summarized on the pod decal.

3-9. FORCING AND INTERRUPT LINES

Several troubleshooter messages are used to indicate errors and conditions associated with forcing lines and interrupts. Forcing lines are those lines which, when made active, force the microprocessor into some specific action. Forcing lines for the 6502 are RDY and $\overline{\text{RESET}}$. Pulling RDY low could cause the pod to stop and timeout. Note that these two lines can be disabled during troubleshooter setup procedures. If the $\overline{\text{RESET}}$ line is pulled low, the pod reports such a condition to the troubleshooter, but pod operation is unaffected.

NOTE

During troubleshooter setup, disabling RDY eliminates any effect they might have on troubleshooter/pod operation. Not reporting (trapping) forcing lines or interrupts during setup simply eliminates the corresponding troubleshooter message.

Interrupt lines for the 6502 include $\overline{\text{IRQ}}$ and $\overline{\text{NMI}}$. The $\overline{\text{IRQ}}$ input is software disabled; the $\overline{\text{NMI}}$ input is hardware disabled except during operation in the RUN UUT mode. When disabled, the $\overline{\text{NMI}}$ input is routinely checked by the pod software, and reported to the troubleshooter if held low by the UUT.

Table 3-2. Status and Control Lines Bit Assignments

STATUS LINES		CONTROL LINES	
BIT NO.	SIGNAL	BIT NO.	SIGNAL
7	PWR FAIL	7	—
6	—	6	—
5	—	5	—
4	** $\overline{\text{RESET}}$	4	R/W
3	$\overline{\text{IRQ}}$	3	—
2	$\overline{\text{NMI}}$	2	—
1	—	1	—
0	** RDY	0	*SYNC

*User Writeable ** Forcing Lines

3-10. LINES ENABLED DURING TROUBLESHOOTER SETUP

During setup of the troubleshooter, the operator has the option of enabling or not enabling certain forcing lines as a means of preventing UUT faults from disabling the pod microprocessor. For the 6502, the RDY line is the only forcing line which may be enabled or disabled. Also during troubleshooter setup, the operator may elect to report (trap) or disregard active signals on the forcing lines. Reporting active forcing lines halts troubleshooter operation in order to display the forcing line message.

3-11. MARGINAL UUT PROBLEMS

3-12. Introduction

The pod is designed to approximate, as closely as possible, the actual characteristics of the microprocessor it replaces in the UUT. However, the pod does differ in some respects. In general, these differences tend to make marginal UUT problems more visible. A UUT may operate marginally with the actual microprocessor installed, but tend to exhibit errors with the pod plugged in. The pod differences tend to make marginal UUT problems more obvious and easier to troubleshoot. Different UUT and pod operating conditions that may reveal marginal problems are described in the paragraphs which follow.

3-13. UUT Operating Speed and Memory Access

UUTs designed to operate at speeds which approach the time limits for memory access, may be operating marginally. Inherent delays present in the pod may result in the reporting of errors in memory, which is otherwise operating marginally.

3-14. UUT Noise Levels

UUTs operate with a certain amount of noise, and as long as the noise level is low enough, normal operation is unaffected. Removing the UUT from its chassis or case may disturb the integrity of the shielding to the point where intolerable noise could exist. The pod may introduce additional noise. In general, marginal noise problems will actually be made worse (and easier to troubleshoot) through use of the pod and troubleshooter.

3-15. Bus Loading

The pod loads the UUT slightly more than the UUT microprocessor. The pod also presents more capacitance than the microprocessor. These effects tend to make any bus drive problems more obvious.

3-16. Clock Loading

The pod increases the normal load on the UUT clock. While this loading will rarely have any affect on clock operation, it may make marginal clock sources more obvious.

3-17. POD DRIVE CAPABILITY

As a driving source on the UUT bus, the pod provides equal to or better than normal 6502 current drive capability. All pod inputs and outputs are TTL compatible.

3-18. POWER FAILURE DETECTION LIMITS

A power sensing circuit within the pod produces a power fail output to the troubleshooter whenever the +5 volt power supply in the UUT drops below or increases above certain limits. The power failure detection limits are listed in the specifications table, Table 1-1.

Section 4

Theory of Operation

4-1. INTRODUCTION

This section contains two block diagram descriptions of the pod. The first is generalized; it describes the operating concept of the pod and the relationship of the pod to the troubleshooter and UUT. The second description covers pod operation in more detail.

4-2. GENERAL POD OPERATION

The pod may be divided into the following three major areas:

- Processor Section
- UUT Interface Section
- Timing Section

4-3. Processor Section

The Processor Section, shown in Figure 4-1, is made up of a microprocessor, RAM, a ROM, and an I/O interface to the troubleshooter. These elements comprise a small computer system which receives troubleshooter commands and directs all pod operations during execution. All reset, non-maskable interrupts, and other disrupting inputs are hardware disabled, or may be software disabled, to prevent UUT faults from disabling the pod microprocessor.

The Processor Section has the capability of operating with the troubleshooter, or with the UUT, but not with both concurrently. The microprocessor spends most of its time monitoring the troubleshooter I/O interface for commands. During this time, the data and address buses of the Processor Section are isolated from the UUT Interface Section (although the pod sends signals to the UUT so that continuous read operations at the reset address appear to be taking place in order to refresh any dynamic RAM).

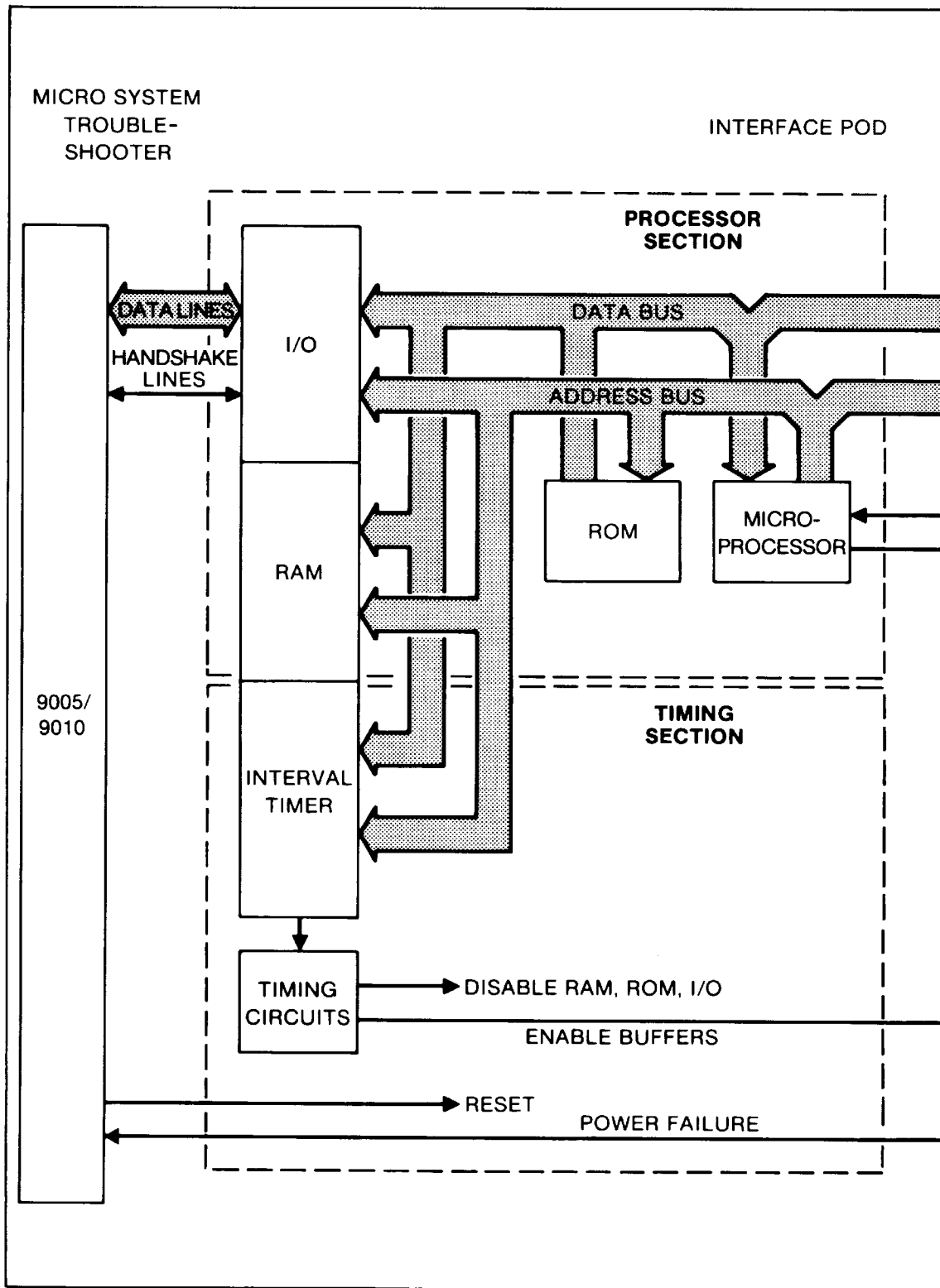

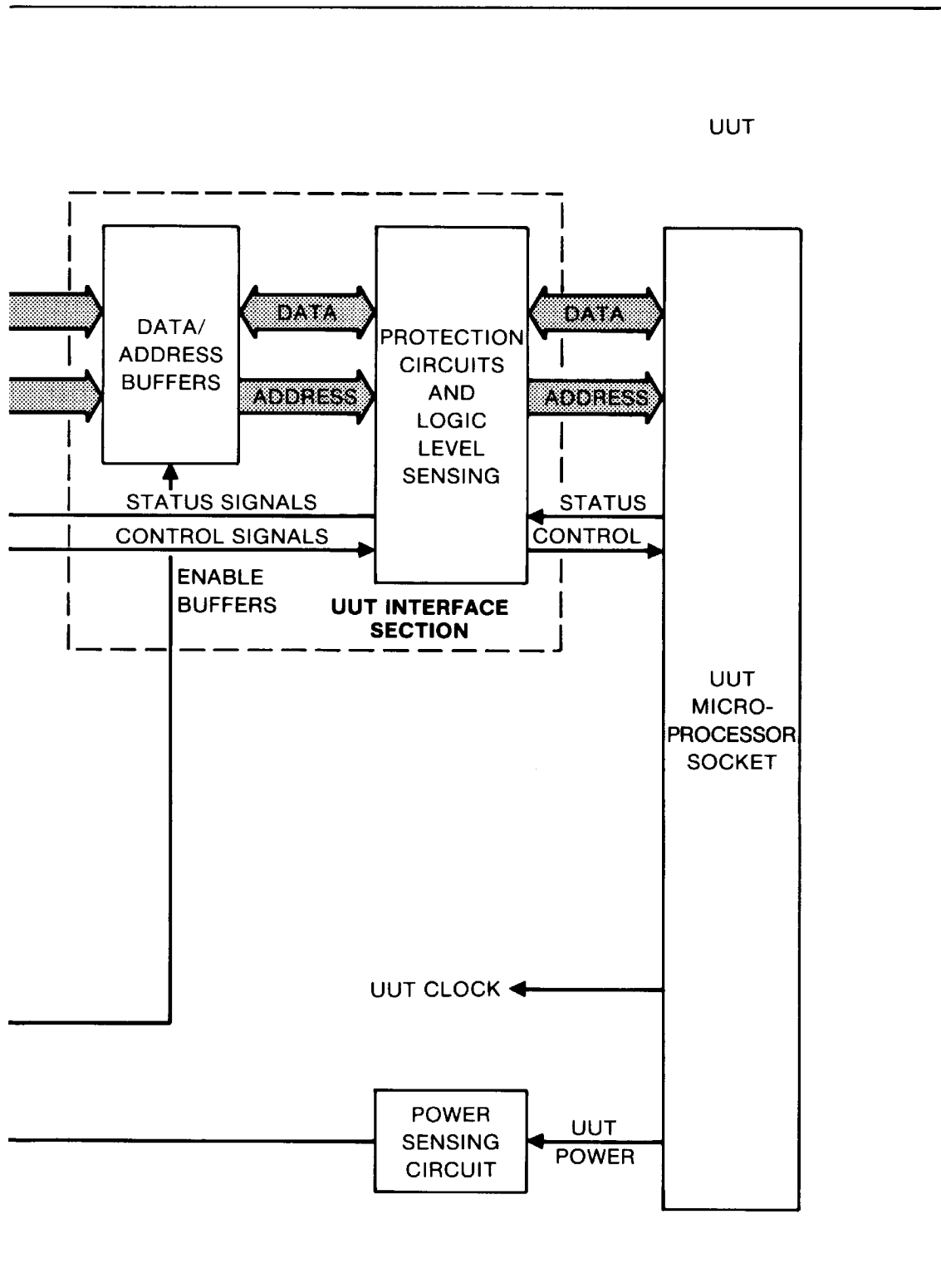

Figure 4-1. General Block Diagram

4-4. UUT Interface Section

The UUT Interface Section, shown in Figure 4-1, include the following elements:

- Data and address buffers
- Protection circuits for signal lines
- Logic level detection circuits for data, address, status and control lines

The data and address buffers are enabled to connect the microprocessor to the UUT, or disabled to isolate the microprocessor from the UUT. Control of the buffers is maintained by the timing section.

Each line to the UUT contains a protection circuit. A protection circuit consists of a 100-ohm series-resistor and clipping diodes. This circuit prevents over voltage conditions from damaging pod components.

Each line to the UUT contains a detection circuit. A detection circuit consists of a latch connected to the UUT side of the 100-ohm protection resistor. The latch senses the level at the UUT side of the protection circuit, and at the conclusion of each UUT operation, stores the level of the UUT line. Each latch is then individually addressed and read by the Processor Section. Their contents are then compared with the desired results as a means of detecting UUT bus faults.

4-5. Timing Section

The primary function of the timing section is to cause the microprocessor to work with either the Processor Section or the UUT Interface Section at a time pre-determined by the microprocessor itself. Causing the microprocessor to work with one section or the other as required during the execution of troubleshooter commands, permits the use of only one microprocessor in the pod.

The Timing Section of the pod, shown in Figure 4-1, consists of an interval timer and an arrangement of timing circuits. The interval timer, preset by the microprocessor, determines the time at which the microprocessor switches from addressing the Processor Section (RAM, ROM and I/O) to addressing the UUT Interface Section (and UUT). This timing is critical, since any attempt by the microprocessor to address the Processor Section with addresses meant for the UUT, or vice versa, would result in improper operation.

In their reset state, the timing circuits cause the microprocessor to operate as a part of the Processor Section, which includes an I/O port to the troubleshooter. When the troubleshooter issues a pod command which calls for a UUT read or write operation, the microprocessor sets the interval timer to a specific value. The value set on the interval timer corresponds to the time needed by the Processor Section to prepare for command execution prior to actually addressing the UUT.

When the interval timer reaches timeout, the timing circuits produce an output to disable RAM, ROM, and I/O, and to enable the buffers of the UUT Interface Section. This action causes the microprocessor to control the UUT Interface Section instead of the Processor Section. At the same time, the microprocessor, having completed preparation for command execution, places a UUT address on the address bus, and UUT data on the data bus (if the command being executed is a write).

After a fixed period of time, the timing circuits terminate the addressing of the UUT, and the microprocessor returns to controlling the RAM, ROM, and I/O elements of the Processor Section. The timing circuits also operate the latches within the logic level detection circuits to store the state of the UUT bus during the UUT bus transaction.

When the RUN UUT mode is commanded, the Timing Section causes the microprocessor to change from controlling the Processor Section to controlling the UUT Interface Section, but does not return control back to the Processor Section. In addition, the $\overline{\text{RESET}}$, $\overline{\text{NMI}}$, and RDY inputs are enabled in the RUN UUT mode. The RUN UUT mode is terminated by a reset signal from the troubleshooter to the pod, which returns control back to the Processor Section.

4-6. UUT Power Sensing

Figure 4-1 also shows a power sensing circuit which constantly monitors the UUT power supply. This circuit produces an output to the troubleshooter in the event UUT power drops below or rises above established limits. See Table 1-1.

4-7. DETAILED BLOCK DIAGRAM DESCRIPTION

The block diagram description that follows covers each of the three pod sections identified in the previous general description of pod operation. A detailed block diagram of the pod is presented in Figure 4-2.

4-8. Processor Section

Refer to Figure 4-2. The Processor Section of the pod is made up of the following components:

- Microprocessor, U4
- ROM, U3
- RAM (128 X 8), U1
- I/O ports A and B, U1
- Address decoder, U7
- Status line buffers, U9

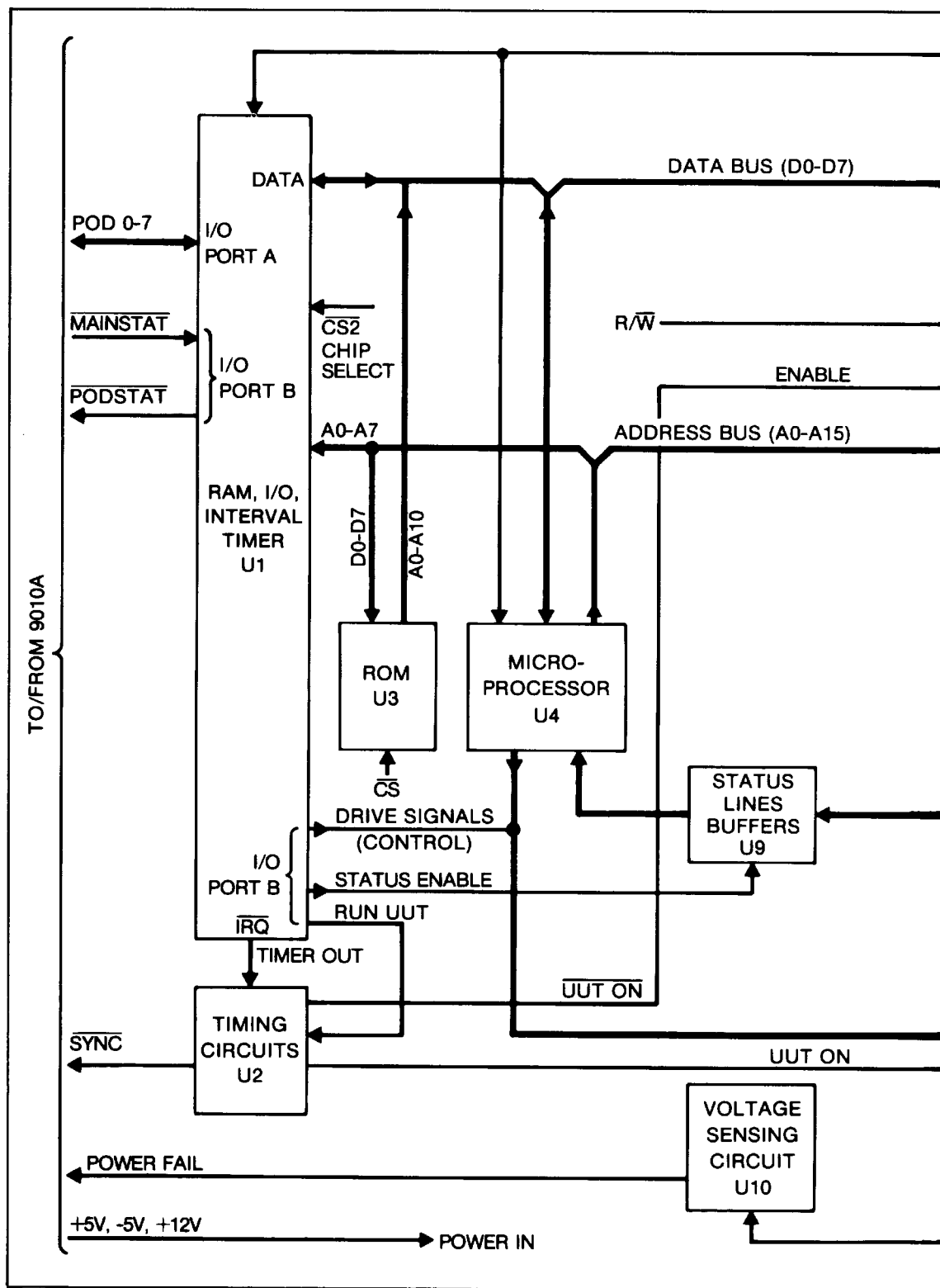

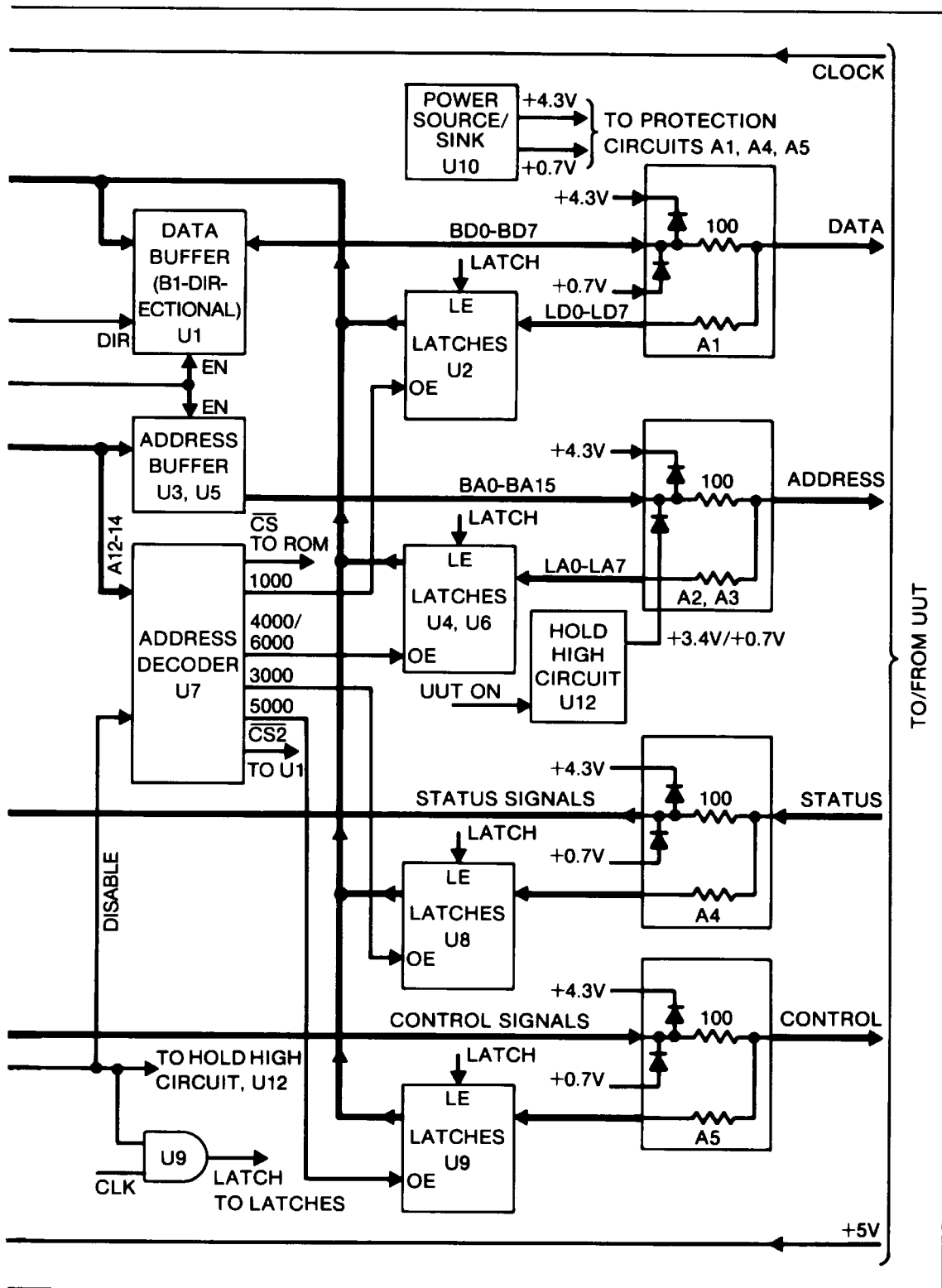

Figure 4-2. Detailed Block Diagram

The Processor monitors the handshake line, $\overline{\text{MAINSTAT}}$, at I/O port B, waiting for troubleshooter commands. The microprocessor addresses I/O port B by means of address lines A0-A7 and address decoder, U7. The address decoder decodes address lines A12-A14 to produce the CS2 signal which selects the RAM-I/O-Interval Timer U1.

The troubleshooter places a low on the $\overline{\text{MAINSTAT}}$ line when a command is placed on lines POD0-7. The microprocessor responds by addressing I/O port A of U4 and reading each byte of the troubleshooter command. As each byte is received, the handshaking lines operate as shown in the upper portion of Figure 4-3 to insure that no data is lost.

Each troubleshooter command causes the microprocessor to execute a corresponding routine contained in ROM U3. This routine, when executed, performs the troubleshooter command by first setting the interval timer (U1) and then performing all necessary internal operations in preparation for addressing the UUT. For example, if the troubleshooter command calls for a write to the UUT, the microprocessor must perform the steps necessary to assemble the UUT address, ready the data to be written, and perform housekeeping operations associated with the command.

In addition, the routine directs the actual write and read functions of the UUT, transmits any response data back to the troubleshooter, and produces a status byte which reflects the current condition of the pod and UUT. During the transmission of data and status back to the troubleshooter, the handshake lines operate as shown in the lower portion of Figure 4-3. The handshake insures that no data is lost during the transmission process.

The microprocessor has the capability of software-driving control line SYNC, as a means of verifying that it can be driven. Also, the microprocessor can control the enabling or disabling of status line RDY as a means of preventing stuck UUT status lines from interfering with pod operation. Both the drive signal for the control line and the enable signals for the status lines are written by the microprocessor through I/O port B of U1.

4-9. UUT Interface Section - General

Refer to Figure 4-2. The UUT Interface Section includes the following components shown in Figure 4-2:

- Bidirectional data buffer, U1
- Protection circuits, A1 - A5
- Address buffers, U3 and U5

- Sensing latches, U2, U4, U6, U8 and U9
- Hold high circuit, U12 and associated components, to hold address lines at FFFF when the UUT is not accessed
- Power source/sink U10 for protection circuits

4-10. UUT Interface Section - Data Lines

The Data Buffer U1 is disabled by the timing circuits whenever the microprocessor is controlling the Processor Section. This disabling prevents data not meant for the UUT from reaching the UUT. Conversely, the data buffer is enabled by the timing circuits when the microprocessor is not controlling the Processor Section, such as, during a UUT read/write operation via data lines BD0-7. The direction of the data buffer is controlled by the DRIVE line, a function of the microprocessor R/ \overline{W} line.

All data passing between the pod and the UUT is fed through a series of protection circuits; one circuit per line. Each protection circuit consists of a 100-ohm resistor in series with the line, and a pair of clipping diodes. The diodes clip the data line at zero and +5 volts.

The data lines are also equipped with logic level detection circuits; one circuit per line. The detection circuits consist of a series of latches coupled to the UUT side of the respective protection circuits. A series resistor at the input of each latch provides overvoltage protection.

The data lines are coupled to the inputs of latches U2 by lines LD0-7. The input to each latch is logic high if the line is driven high, and logic low if the line is driven low. The LATCH signal from the Timing Section latches the data line logic levels, at the time shown in Figure 4-4, to store the logic levels representing the state of each data line.

At the conclusion of a UUT write operation, latches U2 are addressed by the microprocessor. Address decoder U7 produces the address 1000 signal to place the contents of the latches on the data bus. The microprocessor compares the contents of the addressed latches with the intended write data. Any difference between the contents of the latches and the intended data is considered a data error.

4-11. UUT Interface Section - Address Lines

In a manner similar to that described for the data lines, all UUT addresses are fed through a series of protection circuits equipped with resistors and clipping diodes. The diodes used to protect the address lines perform the additional function of holding the address lines at zero volts any time the UUT Interface Section is not controlled by the microprocessor.

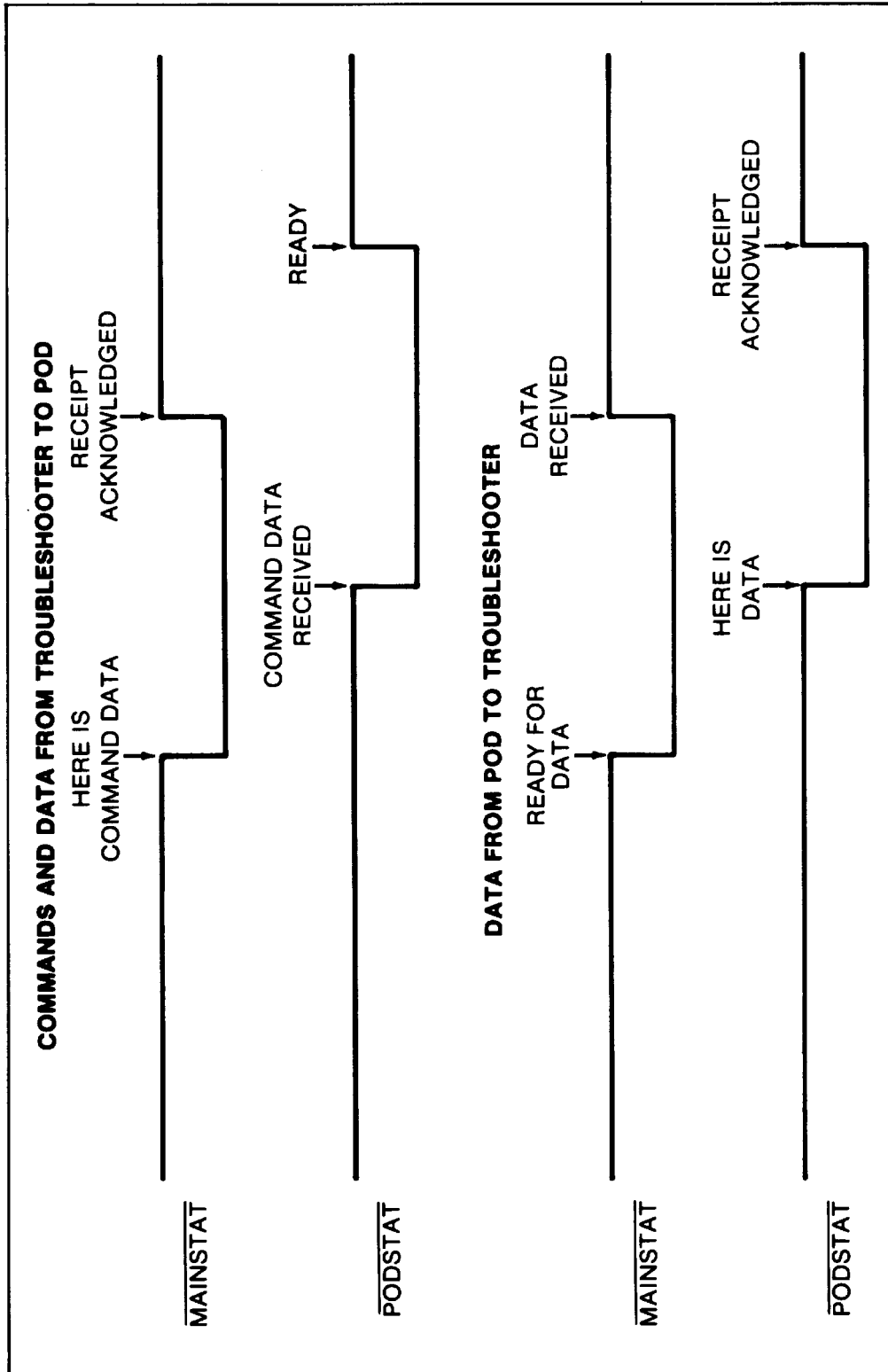

Figure 4-3. Handshaking Signals

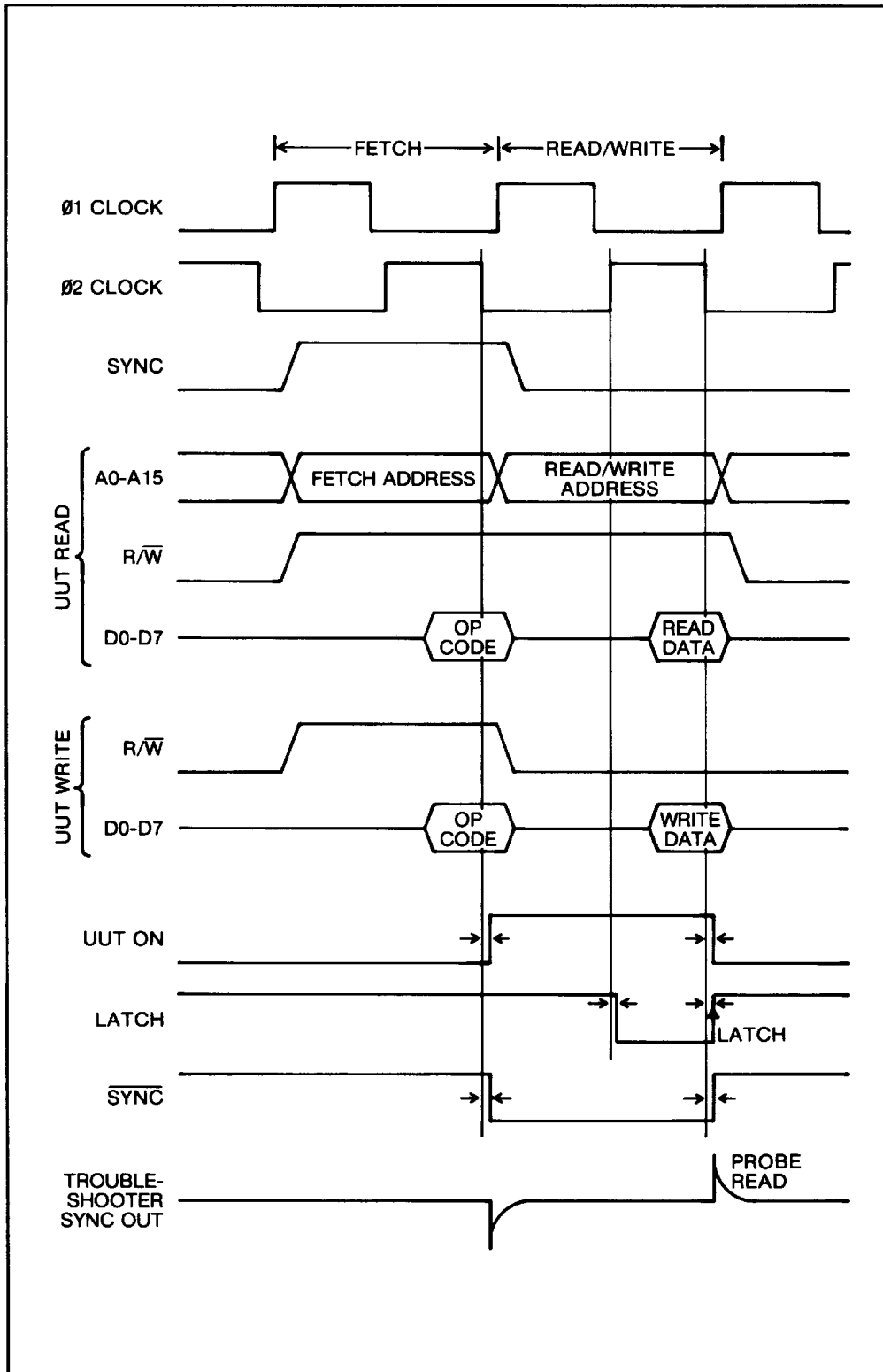

Figure 4-4. UUT ON Signal and Latch Times

Address buffers U3 and U5 are enabled when the microprocessor is controlling the UUT Interface Section. Conversely, the address buffers are disabled to isolate the microprocessor from the UUT whenever the microprocessor is controlling the Processor Section. This isolation prevents the microprocessor from addressing the UUT when operating as part of the Processor Section. In addition, the address lines are held high by the diodes used in the protection circuits.

This holding action is provided by the hold high circuit, made up of U12 and associated components. This circuit drives the +0.7-volt diode clipping voltage up to +3.4 volts whenever the UUT is not being addressed, creating a UUT address of FFFF. Maintaining the UUT at address FFFF prevents any inadvertent operation of the UUT and associated systems equipment.

As described for the data lines, the address lines are equipped with logic level detection circuits; one circuit per line. The detection circuits consist of a series of latches coupled to the UUT side of the respective protection circuits. A series resistor at the input of each latch provides overvoltage protection.

The address lines are coupled to the inputs of latches U4 and U6 by lines LA0-LA15. The input to each latch is logic high if the line is driven high, and logic low if the line is driven low. The LATCH signal from the Timing Section latches the address line logic levels, at the time shown in Figure 4-4, to store the logic levels representing the state of each data line.

At the conclusion of a UUT operation, latches U4 and U6 are separately addressed by the microprocessor. Address decoder U7 produces the address 4000 and 6000 signals to place the contents of the latches on the data bus, one byte at a time. The microprocessor compares the contents of the addressed latches with the actual address. Any difference between the contents of the latches and actual address is considered an address error.

4-12. UUT Interface Section - Status and Control Lines

The status and control lines are provided with protection circuits, logic level detection circuits and latches. These circuits operate in a manner similar to those provided with the data and address lines, and described in the previous paragraphs.

4-13. Timing Section

The timing section consists of the interval timer contained in U1, and timing circuits made up of U2. As mentioned in the description of the Processor Section, the microprocessor executes the troubleshooter command by first setting the interval timer and then performing all necessary internal operations in preparation for addressing the UUT. The interval timer is set to a time equal to the amount of time required by the microprocessor to perform all necessary internal operations.

At the time the interval timer is set, and until the timer times out, a high $\overline{\text{IRQ}}$ output from U1 holds the timing circuits in their reset state. When the timer times out, the $\overline{\text{IRQ}}$ output goes low to enable the timing circuits and produce the UUT ON, $\overline{\text{UUT ON}}$, and the $\overline{\text{SYNC}}$ signals to enable the data and address buffers, and disable the address decoder and send a $\overline{\text{SYNC}}$ pulse back to the troubleshooter. Refer to Figure 4-4 for the timing of the UUT ON signal. The UUT ON signal also disables the hold high circuit, U12, releasing the address bus from the forced UUT address of FFFF.

With the data and address buffers enabled, and the hold high circuit disabled, data and addresses placed on the buses by the microprocessor are directed to the UUT. The Processor Section is disabled at this point by the address decoder U7 which receives the UUT ON signal generated by the timing circuits. With address decoder disabled, the ROM and RAM-I/O-Interval Timer are not selected.

At the time of the next clock pulse, while the microprocessor is still addressing the UUT, the LATCH signal is produced to enable input of each latch circuit. The latches store the condition of all UUT lines.

At the end of the instruction cycle (except in the RUN UUT mode), the timing circuits return to their reset state to disable the data and address buffers, and enable address decoder, U7. This action switches the microprocessor back to control the Processor Section instead of the UUT Interface Section.

The latches store the UUT line logic levels. When addressed by the microprocessor, via address decoder U7, each latch places the condition of the associated UUT line on the data bus. The microprocessor compares the detected UUT line levels with the known expected result and considers any difference to be an error. Any error conditions are indicated in the status byte sent to the troubleshooter at the conclusion of each command.

When the RUN UUT mode is commanded, and the interval timer produces the low $\overline{\text{IRQ}}$ signal, and the timing circuits produce the high UUT ON signal as previously described for the non-RUN UUT mode. However, the RUN UUT command causes the timing circuits to be held in a state which maintains the UUT ON signal and dedicates the microprocessor to the UUT. In this mode, the $\overline{\text{RESET}}$, $\overline{\text{NMI}}$, and RDY inputs are enabled, allowing the UUT to utilize the pod microprocessor in place of the microprocessor removed to facilitate pod connection.

The RUN UUT mode continues until a $\overline{\text{RESET}}$ signal is received from the troubleshooter. The $\overline{\text{RESET}}$ signal causes the microprocessor to resume control of the Processor Section.

Section 5

Maintenance

5-1. INTRODUCTION

This section provides maintenance information for the pod, and includes self test information, repair precautions, disassembly procedures, and troubleshooting information.

5-2. SELF TEST

The troubleshooter can perform a self test on any pod which is operational enough to communicate with the troubleshooter. Self test provides fault location to several areas of the pod by creating appropriate display messages on the troubleshooter. In order to perform self test, the Processor Section (6502 RAM, ROM, I/O, and buses) must be operational. Operation of the processor section is necessary in order for the pod to accept and execute self test commands issued by the troubleshooter.

NOTE

Self test does not examine the pod for all conceivable faults, and may indicate an okay pod when not completely operable. An alternative method of checking pod operability is exercising with a known-good UUT and troubleshooter, observing any reported "UUT failures".

Performance of self test requires that the ribbon cable connector be inserted into the self test socket located on the pod. When the ribbon cable plug is inserted into the self test socket, the following electrical connections are made to facilitate testing (refer also to the schematic diagram contained in Section 7):

- The high order address lines are connected back to the data lines through series resistors. This connection allows the high order address bits to become data during a test read operation.

6502

- A clock signal is applied to the clock input of the pod. This clock signal replaces the clock normally supplied by the UUT to operate the pod.
- All forcing lines and interrupts are set to the active state. Setting these lines allows testing of the individual hardware or software buffering.
- +5V dc is applied to pin 8 to simulate UUT power and check the power fail sensing circuit.
- Ground is applied through the ribbon cable to pins 1 and 21 to notify the troubleshooter that the pod is in the self test configuration.

To perform self test, proceed as follows:

1. If not already connected, connect the interface pod to the troubleshooter as shown in Figure 2-1. Secure the connector using the sliding collar.
2. Open the pins of the self test socket by operating the adjacent thumbwheel. Insert the ribbon cable plug into the socket and close the socket using the thumbwheel.
3. Turn the troubleshooter on and press BUS TEST to initiate self test.
4. If the troubleshooter and pod are operating normally, the troubleshooter display reads *POD SELF-TEST 6502 OK*.
5. If the pod is defective, but not completely dead, the troubleshooter displays *POD SELF-TEST 6502 FAIL xx*, where xx represents the pod fault listed in Table 5-1. Refer to the troubleshooting procedures to further isolate the problem.
6. If the pod is inoperative, the troubleshooter reads *POD TIMEOUT - ATTEMPTING RESET*. This message indicates that the pod is not responding to commands issued by the troubleshooter. Refer to the troubleshooting procedures to isolate the problem.

5-3. REPAIR PRECAUTIONS

CAUTION

Static discharge can damage MOS components contained in the pod. To prevent this possibility, take the following precautions when troubleshooting and/or repairing the unit.

Table 5-1. Self Test Failure Codes

CODE	POSSIBLE FAULT
00	1. UUT power sensing circuit failure 2. Control line(s) cannot be driven 3. Address line(s) cannot be driven 4. Wrong data read
01	1. UUT power sensing circuit failure 2. Control line(s) cannot be driven 3. Address line(s) cannot be driven 4. Data line(s) cannot be driven
01	One or more control lines not driveable
03	Forcing or interrupt line buffer(s) or associated logic faulty.

- Never remove, install, or otherwise connect or disconnect PCB (printed circuit board) assemblies without disconnecting the pod from the troubleshooter.
- Perform all repairs at a static-free work station.
- Do not handle ICs or PCB assemblies by their connectors.
- Attach static ground straps to repair personnel.
- Use conductive foam to store replacement or removed ICs.
- Remove all plastic, vinyl and styrofoam from the work area.
- Use a grounded soldering iron.

The soldering iron used in pod repair should have a rating of 25 watts or less to prevent overheating the PCB assembly.

5-4. TROUBLESHOOTING

5-5. Introduction

Pod failure is usually identifiable from the troubleshooter display. Two types of messages which indicate pod failure are:

- *POD TIMEOUT -ATTEMPTING RESET*; when this message is displayed, the pod does not respond to troubleshooter commands or reset

pulses. This message may be due to stuck forcing lines not disabled during troubleshooter setup procedures described in the Operator Manual.

- Any recurring UUT test-failure or error message when testing a known-good UUT indicates pod failure. Since the UUT is known to be good, errors attributed to the UUT by the troubleshooter are actually pod errors.

Troubleshooting the pod is similar to troubleshooting any other microprocessor-based UUT, and requires the equipment listed in Table 5-2. The troubleshooting information presented in the following paragraphs does not provide step-by-step fault isolation procedures, but provides a troubleshooting guide for use while employing normal fault isolation techniques.

Figure 5-1 shows the non-component side of the interface PCB with component outlines and identification superimposed. Refer to this figure to locate various electrical points on the interface PCB during troubleshooting procedures.

The troubleshooting information should be used in conjunction with the schematic diagrams contained in Section 7 and the Theory of Operation presented in Section 4.

The troubleshooting guidelines presented in the following paragraphs are intended to assist in the isolation of faults within the pod. If attempted troubleshooting fails to reveal the pod fault, return of the pod to the nearest Fluke Service Center is recommended. Refer to the troubleshooter Service Manual for a list of Fluke Service Centers.

Table 5-2. Required Test Equipment

EQUIPMENT TYPE	REQUIRED TYPE
Micro System Troubleshooter Interface Pod Digital Multimeter Oscilloscope	Fluke 9000 Series Fluke 9000A-6502 Fluke 8020 Tektronix 485 or equivalent

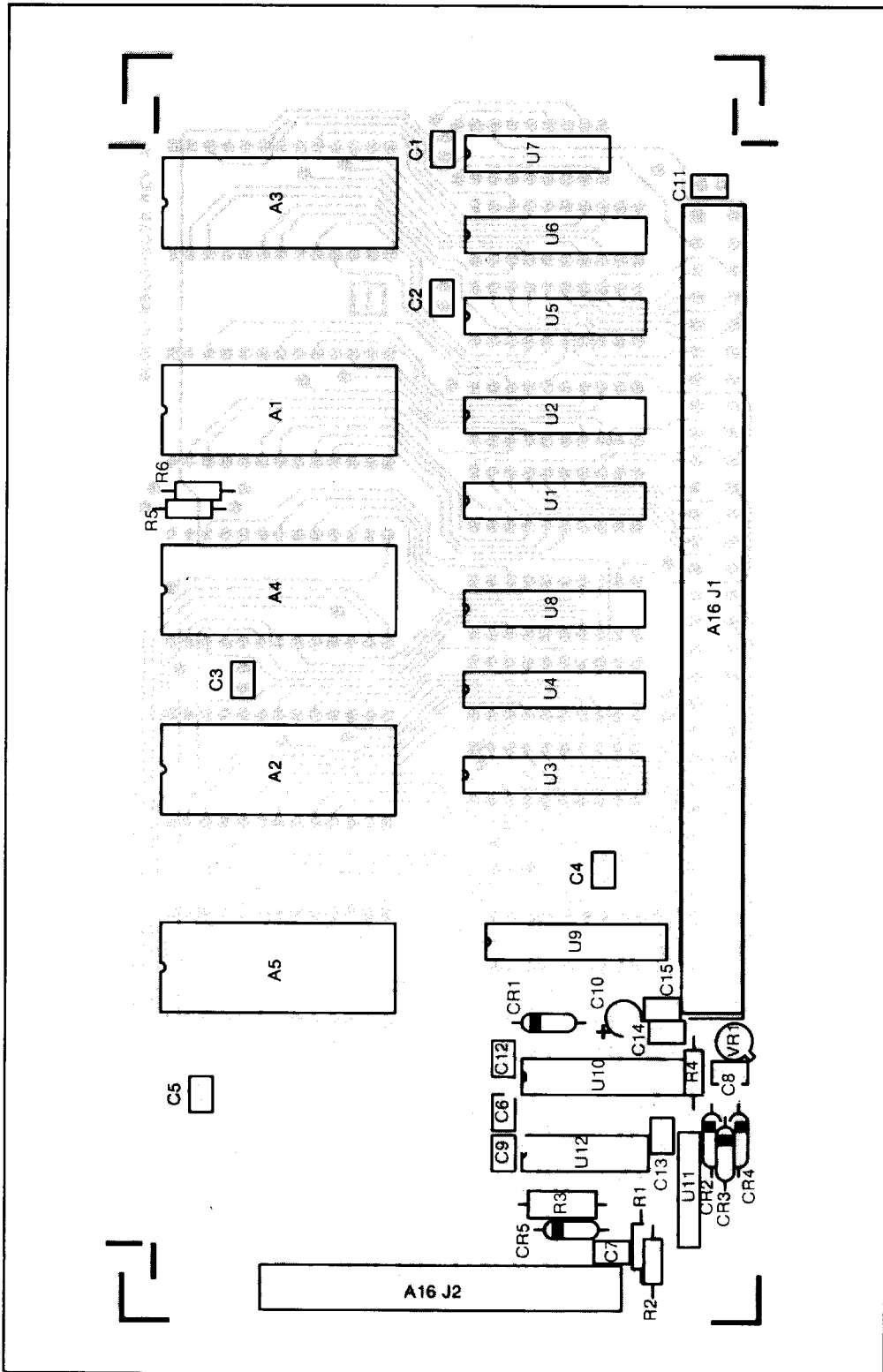

Figure 5-1. Interface PCB, Non-Component Side

5-6. Pod Defective or Inoperative?

Before attempting to repair a faulty pod, the level of failure should be determined. A faulty pod can be categorized as either defective or inoperative, depending upon the result of the self test.

If the result of a self test produces a troubleshooter display of *POD SELF-TEST 6502 FAIL xx*, the pod is considered to be defective but not inoperative. Troubleshoot a defective pod as described under the heading Troubleshooting a Defective Pod. Select a suitable UUT as described under the heading Selecting a UUT for Pod Testing.

NOTE

*It is possible for a pod to produce a self test message of **POD SELF-TEST 6502 OK** and still be faulty. Such a pod causes the display of test-failure or error messages on the troubleshooter when used to test a known-good UUT. In this case, errors attributed to the UUT are actually pod errors.*

If the result of a self test, or any other troubleshooter operation, produces a troubleshooter display of *POD TIMEOUT -ATTEMPTING RESET*, the pod is considered to be inoperative. Troubleshoot an inoperative pod as described under the heading Troubleshooting and Inoperative Pod. Select a suitable UUT as described under the heading Selecting a UUT for Pod Testing.

NOTE

*The **POD TIMEOUT -ATTEMPTING RESET** message can also result from stuck UUT forcing lines which can disable the pod. Forcing lines should be disabled during troubleshooter setup procedures as described in the Operator Manual.*

5-7. Selecting a UUT for Pod Testing

In order to troubleshoot a pod, a known-good UUT must be connected to the pod via the ribbon cable and connector. The UUT may be any device which normally employs a 6502 microprocessor and to which power can easily be applied. The UUT is needed to provide the following functions during pod testing:

- RAM and ROM for performing read/write operations
- 6502 compatible clock signal to drive the pod
- +5V dc UUT power to check the UUT power sensing circuit

Instead of connection to a known-good UUT, the ribbon cable connector may be connected to the self test socket on the pod. The self test socket provides a 6502 compatible clock signal, +5V dc, and also simulates ROM by connecting the high order address lines back to the data lines (refer to the schematic diagram for details).

However, insertion of the ribbon cable connector directly into the self test socket places pins 1 and 21 at ground. The pod senses the ground at pins 1 and 21 and notifies the troubleshooter of the self test connection. As a result, the troubleshooter inhibits normal operation and allows performance of only self test.

During pod troubleshooting procedures, normal troubleshooter operation must be allowed. Consequently, the pod must be prevented from sensing the ribbon cable connector in the self test socket. To prevent the pod from sensing the self test connection, pins 1 and 21 of the connector must be effectively removed.

To effectively remove pins 1 and 21 of the connector, obtain one of the two replacement ribbon cable connectors supplied with the pod, and modify as follows:

1. Carefully separate the connector body halves using a small screwdriver.
2. Remove pins 1 and 21 from the connector and reassemble the body.
3. Insert the modified replacement connector into the self test socket.
4. Insert the ribbon cable connector into the modified replacement connector.

In addition to modifying the ribbon cable connector, be sure to disable all forcing line and interrupt inputs, and set all forcing line and interrupt traps to NO during Setup Editing as described in the Operator Manual. Disabling these inputs and messages is necessary when utilizing the self test socket since all lines are wired to the active state.

5-8. Troubleshooting a Defective Pod

NOTE

The following paragraphs reference three distinct areas of the pod identified as the Processor Section, the UUT Interface Section, and the Timing Circuits. The components which make up these sections are identified in the Theory of Operation, presented in Section 4.

A pod is considered defective when the performance of self test produces a troubleshooter display of *POD SELF TEST 6502 FAIL xx*, where *xx* represents the pod fault listed in Table 5-1. The fact that a self test can be performed indicates operation of the Processor Section, since operation of the Processor Section is necessary for troubleshooter/pod communication. With the Processor Section proven to be good, the UUT Interface Section of the Timing Circuits contain the fault.

Prepare to troubleshoot the defective pod as follows:

1. Disassemble the pod by removing the PCB assemblies from the case, and the shield from the PCB assemblies. (Refer to disassembly information under the heading Disassembly.) It is not necessary to separate the PCB assemblies at this point.
2. Connect the pod to the troubleshooter, and the ribbon cable connector to the UUT, as shown in Figure 5-2. Note that the troubleshooter is connected by means of the shielded cable, and not by means of a second pod, to the microprocessor socket. Also, Figure 5-2 shows the self test socket as the UUT, although any suitable UUT may be used. (Refer to Selecting a UUT for Pod Testing.)

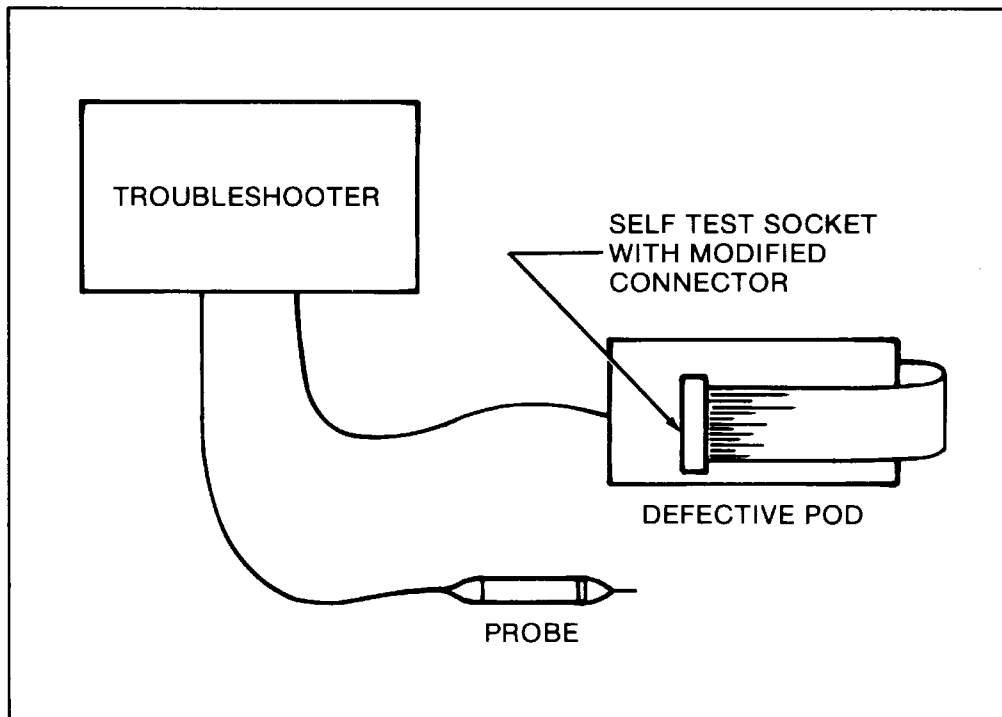

Figure 5-2. Troubleshooting a Defective Pod

NOTE

All references to data and addresses in the following troubleshooting guide are in hexadecimal notation. Unless otherwise noted, all troubleshooter probe operations are performed in the synchronized mode.

NOTE

When troubleshooting a pod, perform looping tests of the most simple type (such as reads and writes as opposed to ROM and RAM tests) that show a fault symptom. A synchronized probe can then be used to trace a fault once such a looping test has it isolated.

5-9. SELF TEST CODE 00

If self test produces a troubleshooter display of *POD SELFT-TEST 6502 FAIL 00*, a UUT read operation has failed and one or more of the following problems is indicated:

- UUT power sensing circuit failure
- Control line(s) cannot be driven
- Address line(s) cannot be driven
- Wrong data read

To further isolate the trouble, proceed as follows:

1. Check operation of the UUT power sensing circuit by verifying the +5 volt UUT supply at the ribbon cable connector and zero volts on the Power Fail line. Check the Power Fail line at the PCB-to-PCB connector, and if necessary, at the shielded cable connector.
2. Perform a read operation. Use address 0FF0 if using the self test socket as the UUT. (The self test socket sends the upper address byte to the data lines. During self test, read operations at 0FF0 and F00F take place.) Use any address containing known data if using some other UUT.
 - a. If the troubleshooter indicates a control line error, examine the entire troubleshooter display to determine the stuck control line(s). While looping on the error, use the probe or a scope to locate the point of control line failure.
 - b. If the troubleshooter indicates an address line error, note the failed address line(s) indicated on the troubleshooter display. While looping on the error, use the probe or a scope to locate the point of address line failure.

c. If the data read, indicated on the troubleshooter display, is not 0F when using the self test socket, or is not identical to the known data of the UUT used for this test, a data line or address line failure is indicated. Determine the failed line(s) from the display and locate the point of failure using the synchronized probe or a scope while performing a looping read operation.

3. Repeat steps 2b and 2c at different addresses and for different data in order to toggle each of the address and data lines.

4. Check for operation of the interval timer and timing circuits by observing pin 25 (\overline{IRQ}) of U1 for a low-going output each time a read operation is executed. If the \overline{IRQ} signal is present, check for a \overline{SYNC} signal at pin 10 of the shielded cable connector, and for a UUT ON signal at the PCB-to-PCB connector. The absence of these signals allows the pod to communicate with the troubleshooter, but prevents the latches from detecting addresses, data, and control signals sent to the UUT (or self test socket). Failure of these signals may also prevent data read from the UUT from reaching the pod microprocessor.

5-10. SELF TEST CODE 01

If self test produces a troubleshooter display of *POD SELF-TEST 6502 FAIL 01*, one or more of the following failures is indicated:

- UUT power sensing circuit failure
- Control line(s) cannot be driven
- Address line(s) cannot be driven
- Data line(s) cannot be driven

To further isolate the trouble, proceed as follows:

1. Check operation of the UUT power sensing circuit by verifying the +5 volt UUT supply at the ribbon cable connector and zero volts on the Power Fail line. Check the Power Fail line at the PCB-to-PCB connector, and if necessary, at the shielded cable connector.

2. Perform a write operation; use 0FF0 for the address and 0F for the data.

a. If the troubleshooter indicates a control line error, examine the entire troubleshooter display to determine the stuck control line(s). While looping on the error, use the probe or a scope to locate the point of control line failure.

- b. If the troubleshooter indicates an address line error, note the failed address line(s) indicated on the troubleshooter display. While looping on the error, use the probe or a scope to locate the point of address line failure.
 - c. If the troubleshooter indicates a data line error, note the failed line(s) indicated on the troubleshooter display. While looping on the error, use the probe or a scope to locate the point of failure.
3. Repeat steps 2b and 2c using F00F for the address and F0 for the data to check address and data lines in the opposite state.
 4. Check for operation of the interval timer and timing circuits by observing pin 25 ($\overline{\text{IRQ}}$) of U1 for a low-going output each time a write operation is executed. If the $\overline{\text{IRQ}}$ signal is present, check for a $\overline{\text{SYNC}}$ signal at pin 10 of the shielded cable connector, and for a UUT ON signal at the PCB-to-PCB connector. The absence of these signals allows the pod to communicate with the troubleshooter, but prevents the latches from detecting addresses, data, and control signals sent to the UUT (or self test socket). Failure of these signals may also prevent write data from reaching the UUT.

5-11. SELF TEST CODE 02

If self test produces a troubleshooter display of *POD SELF-TEST 6502 FAIL 02*, failure of one or more of the control lines is indicated. To check each of the control lines, use the troubleshooter to perform a BUS TEST. Refer to the heading Bit Assignment - Control Lines, located in Section 3, for interpretation of the troubleshooter message.

5-12. SELF TEST CODE 03

If self test produces a troubleshooter display of *POD SELF-TEST 6502 FAIL 03*, failure of one or more status line buffers is indicated. Each of the status (forcing) lines, which have the ability to interrupt or otherwise interfere with microprocessor operation, are selectively buffered from the microprocessor.

Buffering of the RDY line is accomplished by means of gates which are enabled or inhibited by port B outputs of the RAM-I/O-Interval Timer.

5-13. Troubleshooting an Inoperative Pod

NOTE

The following paragraphs reference three distinct areas of the pod identified as the Processor Section, the UUT Interface Section, and the Timing Circuits. The components which make up these sections are identified in the Theory of Operation, presented in Section 4.

A pod is considered inoperative when the performance of self test, or any other troubleshooter operation, produces a troubleshooter message of *POD TIMEOUT-ATTEMPTING RESET*. This troubleshooter message results from a lack of response by the pod to troubleshooter commands. Since it is the function of the Processor Section to respond to troubleshooter commands, lack of response indicates failure of the Processor Section.

Prepare to troubleshoot the inoperative pod as follows:

1. Disassemble the pod. Refer to Disassembly.
2. Remove the microprocessor from its socket.
3. Connect the pod under test to +5 volt and -5 volt power supplies. Apply power to the connector normally coupled to the troubleshooter; use pins 2 and 15 for +5 volts, pin 21 for -5 volts, and pin 25 for ground. If available, use a second troubleshooter and shielded cable to provide power to the pod.
4. Connect a 9000 Series Troubleshooter to a second pod. Apply power to the troubleshooter, then connect the second pod ribbon cable to the microprocessor socket of the pod under test.

CAUTION

Do not apply or remove any power with ribbon cable connected between second pod and inoperative pod.

NOTE

All references to data and addresses in the following troubleshooting guide are in hexadecimal notation.

With reference to the Theory of Operation contained in Section 4 and the schematic diagram contained in Section 7, troubleshoot an inoperative pod using the following steps as a guide:

1. Reset the pod by momentarily shorting pins 22 and 23 of the shielded cable connector located on the upper PCB assembly.
2. Perform a BUS TEST.
3. Perform a RAM SHORT and RAM LONG TEST. The RAM addresses are listed in Table 5-3.
4. Perform a ROM TEST. The ROM addresses are listed in Table 5-3.

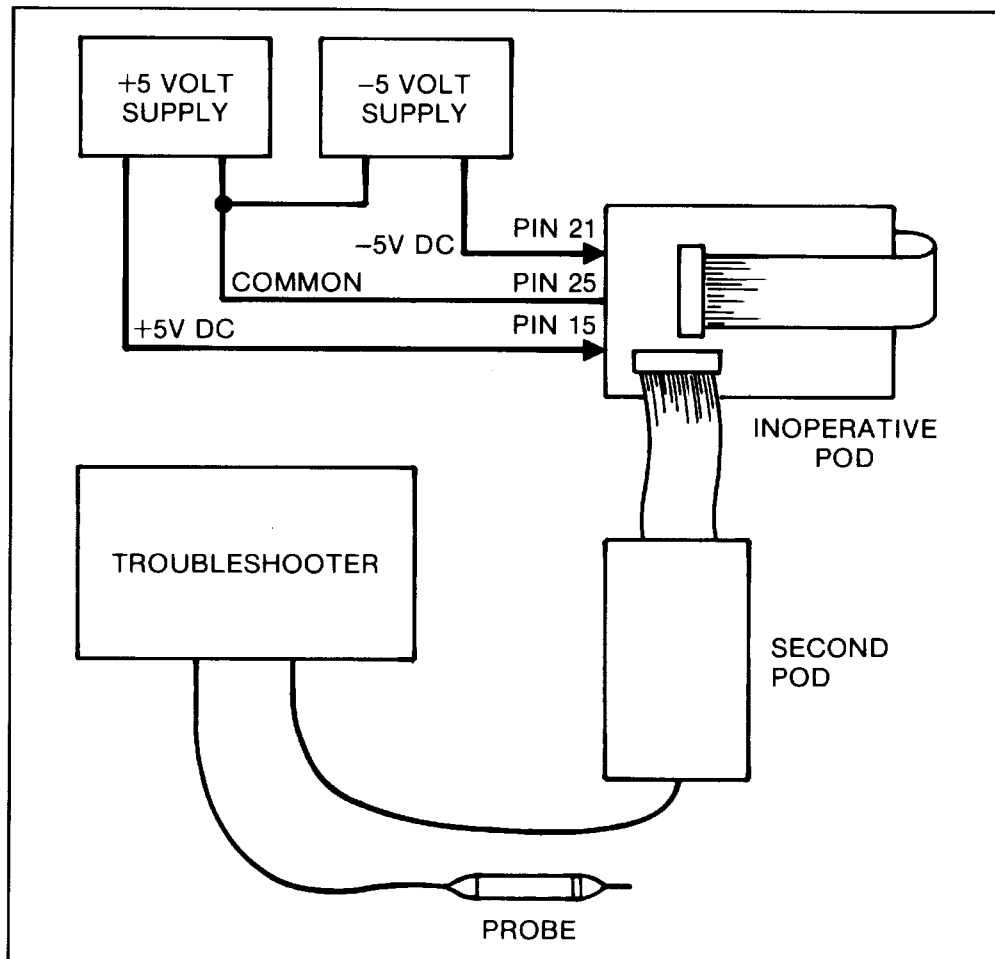

Figure 5-3. Troubleshooting an Inoperative Pod

Table 5-3. 6502 Pod Memory and I/O Addresses

ADDRESSABLE DEVICE	ADDRESS (HEX)
RAM	0000 - 007F
ROM	FC00 - FFFF
I/O-Port A Direction Register	0081
-Port A Data Register	0080
-Port B Direction Register	0083
-Port B Data Register	0082
Interval Timer -Divide by 1	009C
Interval Timer Disable	0094

5. Check the output operation of I/O port A (contained in U1) as follows:
 - a. Perform a write operation to the port A direction register to set all lines of I/O port A (PA0-PA7) as outputs. The write address is 0081; write data is FF.
 - b. Perform a write operation to the port A data register to set all bits high. The write address is 0080; write data is FF.
 - c. Check the port A lines (PA0-PA7) with the probe or scope for all logic high levels.
 - d. Repeat step b with 00 as the write data.
 - e. Repeat step c, checking for all logic low levels.
6. Check the input operation of I/O port A (contained in U1) as follows:
 - a. Perform a write operation to the port A direction register to set all lines of I/O port A (PA0-PA7) as inputs. The write address is 0081; write data is 00.
 - b. Perform a read operation at the port A data register, address 0080, while sequentially applying the probe (with high pulses selected) to each of the port A input pins (pins 8-15 of U1) and observing the troubleshooter display. The troubleshooter should indicate each high input of port A.
7. Check the output operation of port B (PB0-PB7) by repeating step 5 and using address 0083 for the port B direction register, and address 1082 for the port B data register.
8. Check the input operation of port B, line PB7 ($\overline{\text{MAINSTAT}}$) by repeating step 6. Use address 0083 for the port B direction register and write data 00 to set line PB7 as an input. Perform the looping read at address 0082 and apply +5 volts to U1, pin 16.
9. Check operation of the interval timer (contained in U1) by performing a write operation at address 009C; write data = 0F. Verify that the $\overline{\text{IRQ}}$ output of U1 goes low in response to the write operation.
10. Check for the occurrence of the UUT ON signal (produced by the timing circuits as a result of the low $\overline{\text{IRQ}}$ signal) at the PCB-to-PCB connector.

11. Check for the occurrence of the $\overline{\text{SYNC}}$ signal at pin 10 of the shielded cable connector.
12. Check the address decoder by performing read operations at addresses 0000, 2000, 3000, 4000, 5000, 6000, and 7000. Verify that the respective decoder output goes low when addressed.
13. If repairs have been made to the inoperative pod as a result of the preceding checks, attempt self test. If self test operates, but the pod fails, refer to Troubleshooting a Defective Pod.

The troubleshooting guidelines presented in the preceding paragraphs are intended to assist in the isolation of faults within the pod. If attempted troubleshooting fails to reveal the pod fault, return of the pod to the nearest Fluke Service Center is recommended. Refer to the troubleshooter Service Manual for a list of Fluke Service Centers.

5-14. DISASSEMBLY

To gain access to the two PCB assemblies within the pod, proceed as follows:

1. Remove the ribbon cable plug from the self test socket.
2. Remove the four phillips screws holding the pod case halves together and carefully open the case.
3. With the PCB assemblies removed from the case halves, remove the screw which retains the shield. Remove the shield.

NOTE

To troubleshoot the pod, it may not be necessary to separate the two PCB assemblies except to replace components. Figure 5-1 shows the location of each component on the lower PCB assembly relative to the accessible non-component side of the board.

4. If it is not necessary to separate the two PCB assemblies, temporarily replace the shield retaining screw; otherwise, remove the second screw from its standoff and carefully pull the boards apart at the connector.
5. To operate the pod with the two printed circuit boards separated from each other, reconnect them in a side-by-side fashion using the test adapter, Fluke part no. 613828. Make sure that correct pin-to-pin relationships are maintained.

Section 6

List of Replaceable Parts

6-1. INTRODUCTION

This section contains an illustrated parts breakdown of the instrument. Components are listed alphanumerically by assembly.

Parts lists include the following information:

1. Reference Designation.
2. Description of Each Part.
3. FLUKE Stock Number.
4. Federal Supply Code for Manufacturers. (See the 9000 Series Troubleshooter Service Manual for Code-to-Name list).
5. Manufacturer's Part Number.
6. Total Quantity of Components Per Assembly.
7. Recommended quantity: This entry indicates the recommended number of spare parts necessary to support one to five instruments for a period of 2 years. This list presumes an availability of common electronic parts at the maintenance site. For maintenance for 1 year or more at an isolated site, it is recommended that at least one of each assembly in the instrument be stocked.

6-2. HOW TO OBTAIN PARTS

Components may be ordered directly from the manufacturer's part number, or from the John Fluke Mfg. Co., Inc. or an authorized representative by using the FLUKE STOCK NUMBER.

6502

In the event the part ordered has been replaced by a new or improved part, the replacement will be accompanied by an explanatory note and installation instructions if necessary.

To ensure prompt and efficient handling of your order, include the following information.

1. Quantity.
2. FLUKE Stock Number.
3. Description.
4. Reference Designation.
5. Printed Circuit Board Part Number and Revision Letter.
6. Instrument Model and Serial Number.

A Recommended Spare Parts Kit for your basic instrument is available from the factory. This kit contains those items listed in the REC QTY column for the parts lists in the quantities recommended.

Parts price information is available from the John Fluke Mfg. Co., Inc. or its representative. Prices are also available in a Fluke Replacement Parts Catalog, which is available upon request.

CAUTION



Indicated devices are subject to damage by static discharge.

Table 6-1. 9000A-6502 Interface Pod Final Assembly

REF DES	DESCRIPTION	FLUKE STOCK NO.	MFG SPLY CODE	MFG PART NO.	TOT QTY	REC QTY	N O T E
	9000A-6502 INTERFACE POD FINAL ASSY. FIGURE 6-1 (9000A-6502-5071)	ORDER BY	MODEL #	9000A-6502			
A15	⊗ PROCESSOR PCB ASSEMBLY	579482	89536	579482	1		
A16	⊗ INTERFACE PCB ASSEMBLY	581272	89536	581272	1		
H1	SCREW, PHP, 4-40 X 1/4	185918	89536	185918	2		
H2	SCREW, PHP, 4-40 X 1/2	152132	89536	152132	4		
MP1	DECAL, 6502 POD	536714	89536	536714	1		
MP2	DECAL, 6502 SPEC	584250	89536	584250	1		
MP3	CASE, (BOTTOM)	579573	89536	579573	1		
MP4	KNOB, ACCUATOR	582916	89536	582916	1		
MP5	CASE, (TOP)	579565	89536	579565	1		
MP6	SHIELD	586479	89536	586479	1		
W1	CABLE ASSEMBLY, POD	581827	89536	581827	1		
W2	CABLE, UUT	585141	89536	585141	1		

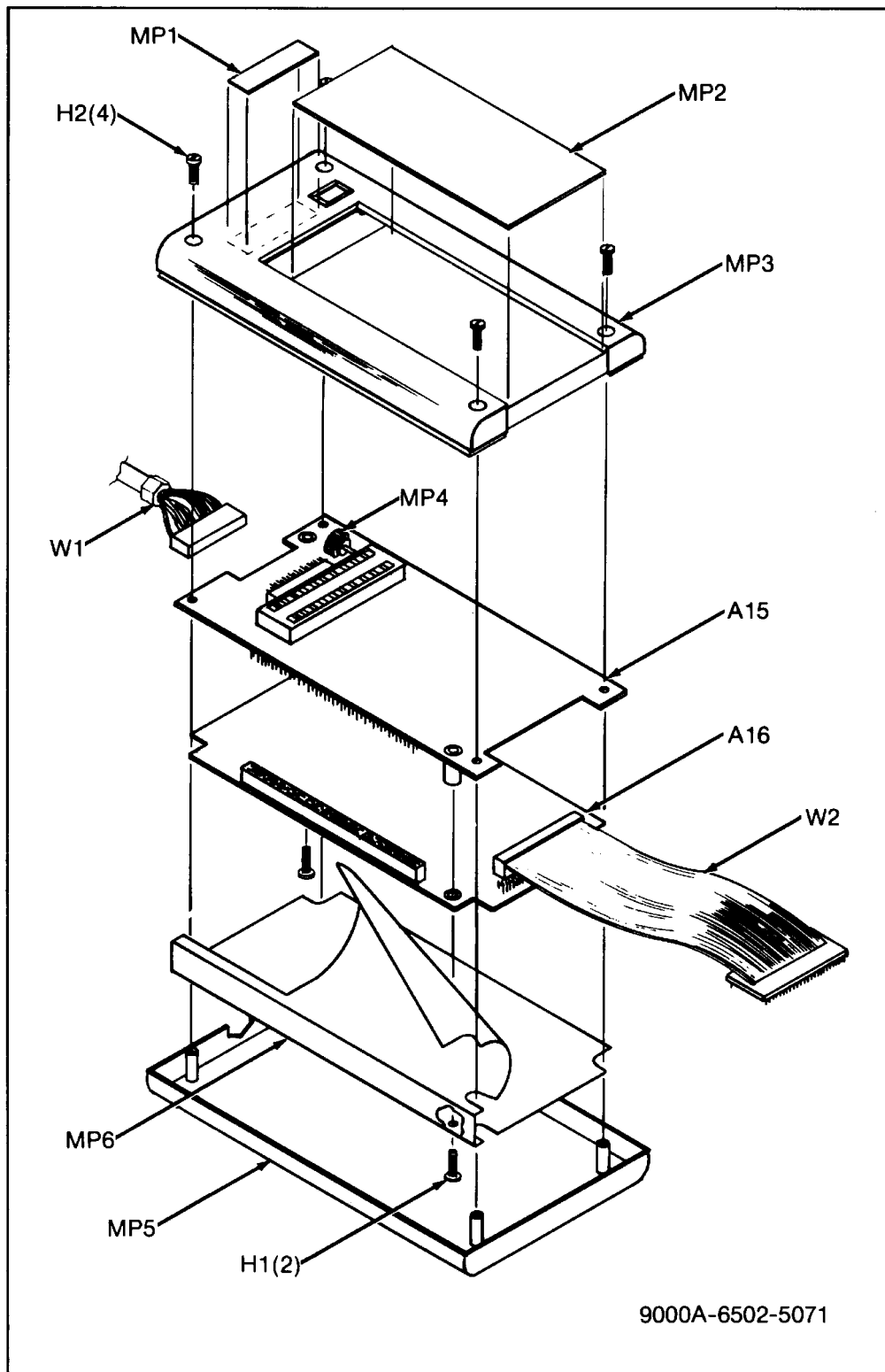

Figure 6-1. 9000A-6502 Interface Pod Final Assembly

Table 6-2. A15 Processor PCB Assembly

REF DES	DESCRIPTION	FLUKE STOCK NO.	MFG SPLY CODE	MFG PART NO.	TOT QTY	REC QTY	W O T E
A15	Ø 9000A-6502 PROCESSOR PCB ASSEMBLY FIGURE 6-2 (9000A-6502-4071T)	579482	89536	579482	REF		
C1	CAP, CER, 0.22 UF +/-20%, 50V	519157	51406	RPE111Z5U224M50V	7		
C2	CAP, CER, 0.22 UF +/-20%, 50V	519157	51406	RPE111Z5U224M50V	REF		
C3	CAP, CER, 0.22 UF +/-20%, 50V	519157	51406	RPE111Z5U224M50V	REF		
C4	CAP, CER, 0.22 UF +/-20%, 50V	519157	51406	RPE111Z5U224M50V	REF		
C5	CAP, CER, 0.22 UF +/-20%, 50V	519157	51406	RPE111Z5U224M50V	REF		
C6	CAP, CER, 0.22 UF +/-20%, 50V	519157	51406	RPE111Z5U224M50V	REF		
C7	CAP, CER, 0.22 UF +/-20%, 50V	519157	51406	RPE111Z5U224M50V	REF		
C8	CAP, CER, 22 PF +/-5%, 100V	448449	80031	2222-638-10229	1		
J1	POST CONTACT HEADER, 26-POS	512590	89536	512590	1		
MP1	SPACER, STANDOFF (NOT SHOWN)	602284	89536	602284	2		
P1	CONNECTOR, AMP PIN	513879	00779	4-870221	60		
R1	RES, DEP. CAR, 51 +/-5%, 1/4W	414540	80031	CR251-4-5P51E	1		
R2	RES, DEP. CAR, 1K +/-5%, 1/4W	343426	80031	CR251-4-5P1K	1		
R3	RES, COMP, 4.7K +/-5%, 1/4W	348821	01121	CB4725	4		
R4	RES, COMP, 4.7K +/-5%, 1/4W	348821	01121	CB4725	REF		
R5	RES, COMP, 4.7K +/-5%, 1/4W	348821	01121	CB4725	REF		
R6	RES, COMP, 4.7K +/-5%, 1/4W	348821	01121	CB4725	REF		
R7	RES, DEP. CAR, 2.2K +/-5%, 1/4W	343400	80031	CR251-4-5P2K2	1		
U1	Ø IC, RAM, I/O, TIMER ARRAY	536417	55576	SYP6532A	1	1	
U2	Ø IC, TTL, DUAL, J-K FLIP-FLOP	414029	01295	SN74LS112N	1	1	
U3	Ø IC, ROM, 16K	536599	89536	536599	1	1	
U4	Ø IC, N-MOS, 8-BIT, MICROPROCESSOR	535807	55576	SYP6502B	1	1	

Table 6-2. A15 Processor PCB Assembly (cont)

REF DES	DESCRIPTION	FLUKE STOCK NO.	MFG SPLY CODE	MFG PART NO.	TOT QTY	REC QTY	N O T E
U5	⊕ IC, TTL, C-MOS, 6800 CLOCK GENERATOR	586065	04713	MC6875L	1	1	
U6	IC, TTL, QUAD, 2-INPUT, POS NAND GATE	393033	01295	SN74LS00N	1	1	
U7	IC, TTL, QUAD BUS BUFFERS	472746	01295	SN74LS125N	1	1	
U8	IC, TTL, HEX INVERTER	393058	01295	SN74LS04N	1	1	
U9	IC, TTL, QUAD, 2-INPUT, POS AND GATES	393066	01295	SN74LS08N	1	1	
U10	IC, TTL, QUAD, 2-IN POS OR GATE	393108	01295	SN74LS32N	1	1	
U11	IC, TTL, QUAD, 2-IN POS OR GATE	393108	01295	SN74LS32N	REF		
U12	RESISTOR NETWORK, 2K	574905	89536	574905	1	1	
U13	RESISTOR NETWORK, 4.7K	412916	89536	412916	1	1	
U14	RESISTOR NETWORK, 4.7K	484063	89536	484063	1	1	
W2	WIRE, JUMPER	529776	89536	529776	7		
W3	WIRE, JUMPER	529776	89536	529776	REF		
W6	WIRE, JUMPER	529776	89536	529776	REF		
W8	WIRE, JUMPER	529776	89536	529776	REF		
W12	WIRE, JUMPER	529776	89536	529776	REF		
W13	WIRE, JUMPER	529776	89536	529776	REF		
W20	WIRE, JUMPER	529776	89536	529776	REF		
XU1	SOCKET, IC, 40-PIN	429282	09922	DILB40P-108	2		
XU3	SOCKET, IC, 24-PIN	376236	91506	324-AG39D	1		
XU4	SOCKET, IC, 40-PIN	429282	09922	DILB40P-108	REF		

Table 6-3. A16 Interface PCB Assembly

REF DES	DESCRIPTION	FLUKE STOCK NO.	MFG SPLY CODE	MFG PART NO.	TOT QTY	REC QTY	N O T E
A16	9000A-6800 INTERFACE PCB ASSEMBLY FIGURE 6-3 (9000A-6800-4072T)	581272	89536	581272	REF		
A16A1	HYBRID, PROTECTION CIRCUIT	583021	89536	583021	5		
A16A2	HYBRID, PROTECTION CIRCUIT	583021	89536	583021	REF		
A16A3	HYBRID, PROTECTION CIRCUIT	583021	89536	583021	REF		
A16A4	HYBRID, PROTECTION CIRCUIT	583021	89536	583021	REF		
A16A5	HYBRID, PROTECTION CIRCUIT	583021	89536	583021	REF		
C1	CAP, CER, .22 UF +/-20%, 50V	519157	51406	RPE111Z5U224M50V	12		
C2	CAP, CER, .22 UF +/-20%, 50V	519157	51406	RPE111Z5U224M50V	REF		
C3	CAP, CER, .22 UF +/-20%, 50V	519157	51406	RPE111Z5U224M50V	REF		
C4	CAP, CER, .22 UF +/-20%, 50V	519157	51406	RPE111Z5U224M50V	REF		
C5	CAP, CER, .22 UF +/-20%, 50V	519157	51406	RPE111Z5U224M50V	REF		
C6	CAP, CER, .22 UF +/-20%, 50V	519157	51406	RPE111Z5U224M50V	REF		
C7	CAP, CER, .22 UF +/-20%, 50V	519157	51406	RPE111Z5U224M50V	REF		
C8	CAP, CER, .22 UF +/-20%, 50V	519157	51406	RPE111Z5U224M50V	REF		
C9	CAP, CER, 0.01 UF +/-20%, 100V	407361	72982	8121-A100-W5R-103M	1		
C10	CAP, TA, 1 UF +/-20%, 35V	161919	56289	196D010X0035G	1		
C11	CAP, CER, .22 UF +/-20%, 50V	519157	51406	RPE111Z5U224M50V	REF		
C12	CAP, CER, .22 UF +/-20%, 50V	519157	51406	RPE111Z5U224M50V	REF		
C13	CAP, CER, .22 UF +/-20%, 50V	519157	51406	RPE111Z5U224M50V	REF		
C15	CAP, CER, .22 UF +/-20%, 50V	519157	51406	RPE111Z5U224M50V	REF		
CR1	DIODE, SI, HI-SPEED SWITCHING	203323	07910	1N4448	5	1	
CR2	DIODE, SI, HI-SPEED SWITCHING	203323	07910	1N4448	REF		
CR3	DIODE, SI, HI-SPEED SWITCHING	203323	07910	1N4448	REF		

Table 6-3. A16 Interface PCB Assembly (cont)

REF DES	DESCRIPTION	FLUKE STOCK NO.	MFG SPLY CODE	MFG PART NO.	TOT QTY	REC QTY	NOTE
CR4	DIODE, SI, HI-SPEED SWITCHING	203323	07910	1N4448	REF		
CR5	DIODE, SI, HI-SPEED SWITCHING	203323	07910	1N4448	REF		
J1	CONNECTOR, 60-PIN	602813	00779	86396-6	1		
J2	CONNECTOR, POST	267500	00779	86144-2	40		
R1	RES, DEP. CAR, 1K +/-5%, 1/4W	343426	80031	CR251-4-5P1K	2		
R2	RES, DEP. CAR, 1K +/-5%, 1/4W	343426	80031	CR251-4-5P1K	REF		
R3	RES, COMP, 120 +/-10%, 1/2W	108696	01121	RC20GF120KS	1		
R4	RES, DEP. CAR, 2.2K +/-5%, 1/4W	343400	80031	CR251-4-5P2K2	1		
R5	RES, DEP. CAR, 200 +/-5%, 1/4W	441451	80031	CR251-4-5P200E	2		
R6	RES, DEP. CAR, 200 +/-5%, 1/4W	441451	80031	CR251-4-5P200E	REF		
U1	⊗ IC, C-MOS, OCTAL BUS TRANSCEIVER	535906	36665	74C245AC	3	1	
U2	⊗ IC, C-MOS, OCTAL LATCH HI-SPEED	585364	36665	74SC374A	5	1	
U3	⊗ IC, C-MOS, OCTAL BUS TRANSCEIVER	535906	36665	74C245AC	REF		
U4	⊗ IC, C-MOS, OCTAL LATCH HI-SPEED	585364	36665	74SC374A	REF		
U5	⊗ IC, C-MOS, OCTAL BUS TRANSCEIVER	535906	36665	74C245AC	REF		
U6	⊗ IC, C-MOS, OCTAL LATCH HI-SPEED	585364	36665	74SC374A	REF		
U7	IC, TTL, LO-PWR, 3-8 LINE DECODER	407585	01295	SN74LS138N	1	1	
U8	⊗ IC, C-MOS, OCTAL LATCH HI-SPEED	585364	36665	74SC374A	REF		
U9	⊗ IC, C-MOS, OCTAL LATCH HI-SPEED	585364	36665	74SC374A	REF		
U10	IC, PROTECTOR	585992	89536	585992	1		
U11	RESISTOR NETWORK	583476	89536	583476	1	1	
U12	IC, TTL, DUAL 4-INPUT NAND LINE DRIVER	585414	01295	SN74S140N	1	1	
VR1	IC, LIN, LOW VOLTAGE REFERENCE	452771	89536	452771	1	1	
XU1	SOCKET, IC, 20-PIN	454421	01295	C932002	3		
XU3	SOCKET, IC, 20-PIN	454421	01295	C932002	REF		

Table 6-3. A16 Interface PCB Assembly (cont)

REF DES	DESCRIPTION	FLUKE STOCK NO.	MFG SPLY CODE	MFG PART NO.	TOT QTY	REC QTY	N O T E
XU5	SOCKET, IC, 20-PIN	45421	01295	C932002	REF		
XU10	SOCKET, IC, 18-PIN	413229	01295	C 93102	1		
XVR1	INSULATOR (NOT SHOWN)	175125	89536	175125	1		

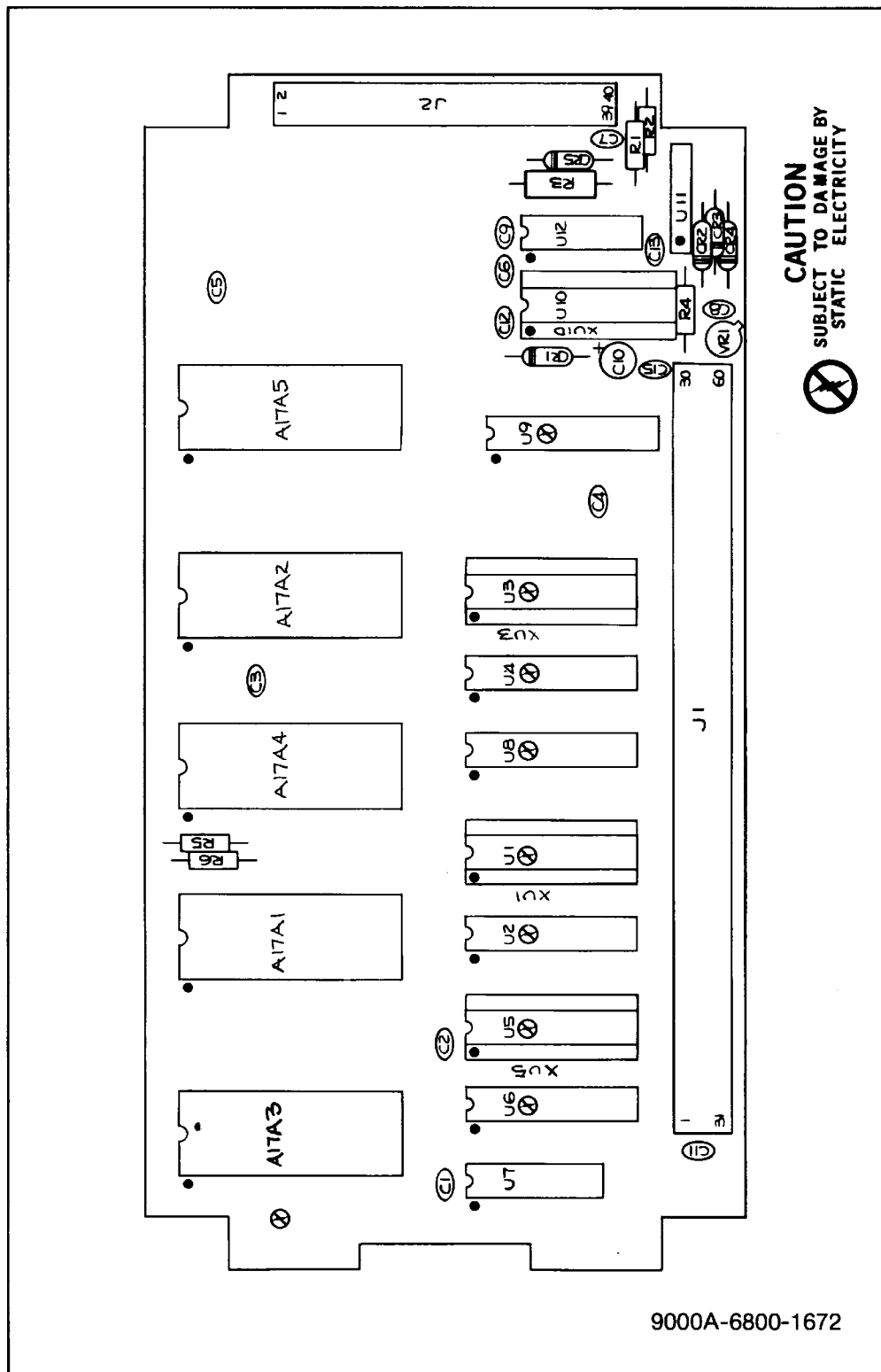

Figure 6-3. A16 Interface PCB Assembly

Section 7

Schematic Diagrams

TABLE OF CONTENTS

FIGURE	TITLE	PAGE
7-1.	A15 Processor PCB Assembly	7-2
7-2.	A16 Interface PCB Assembly	7-4

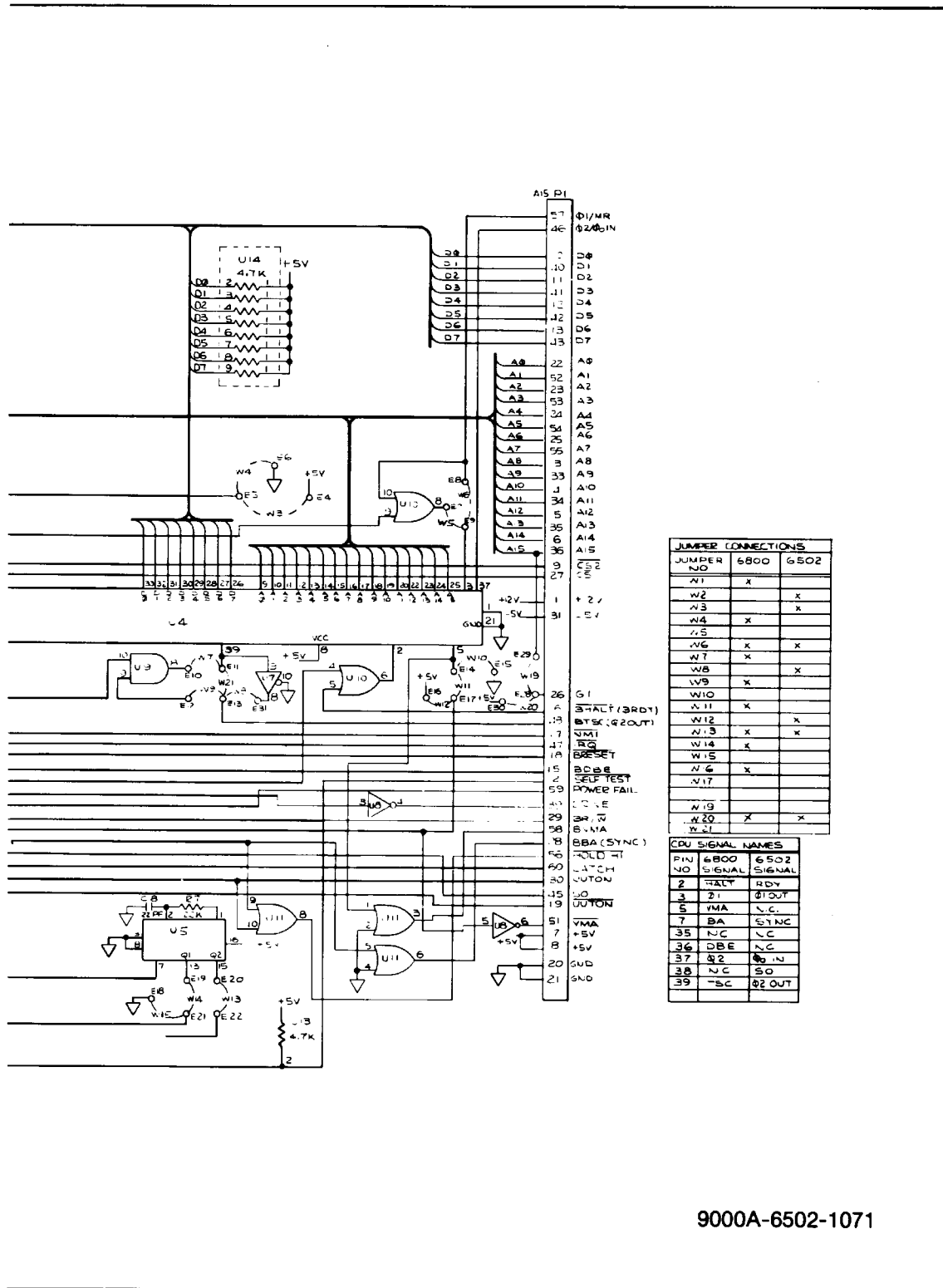
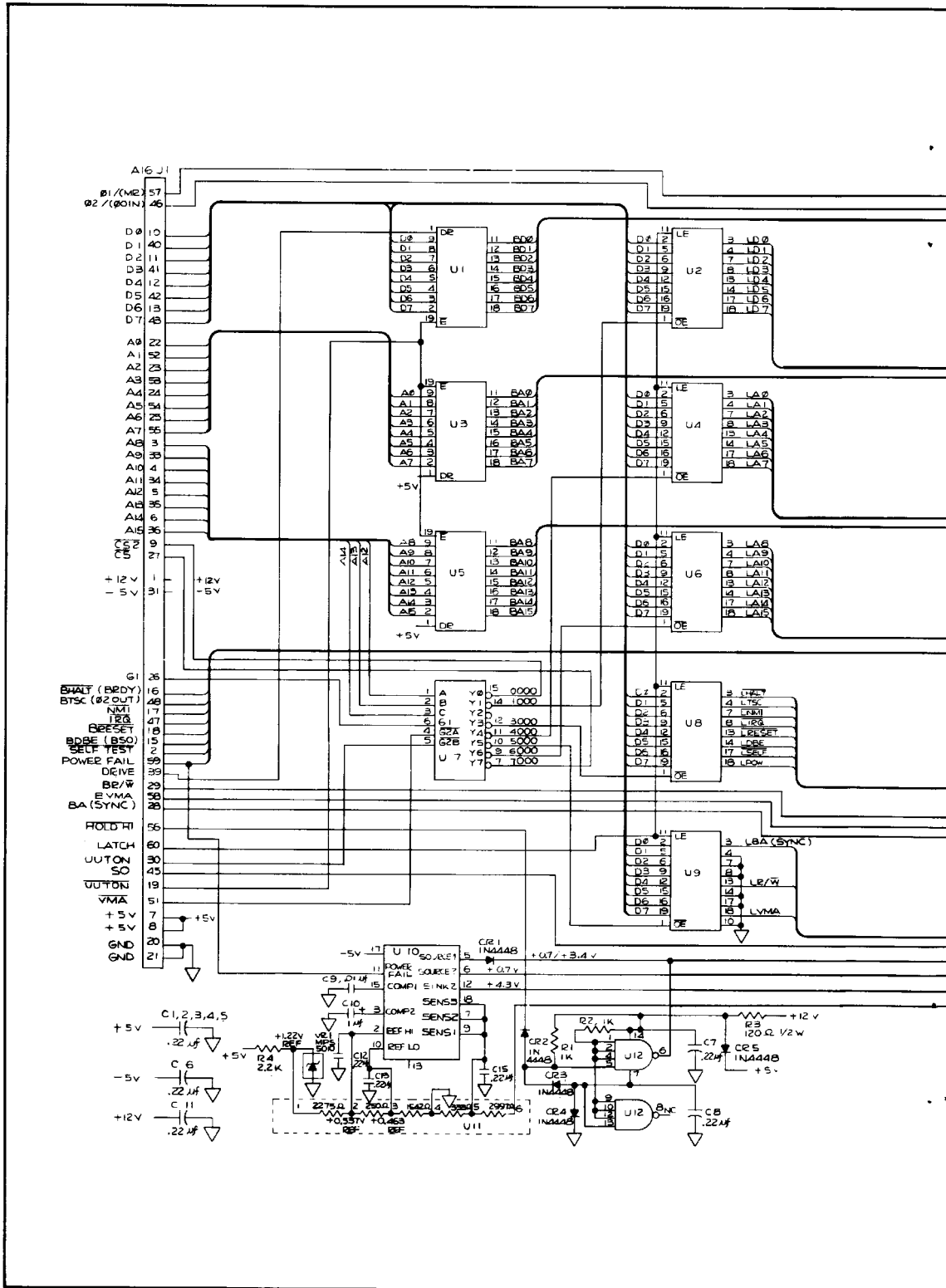

Figure 7-1. A15 Processor PCB Assembly



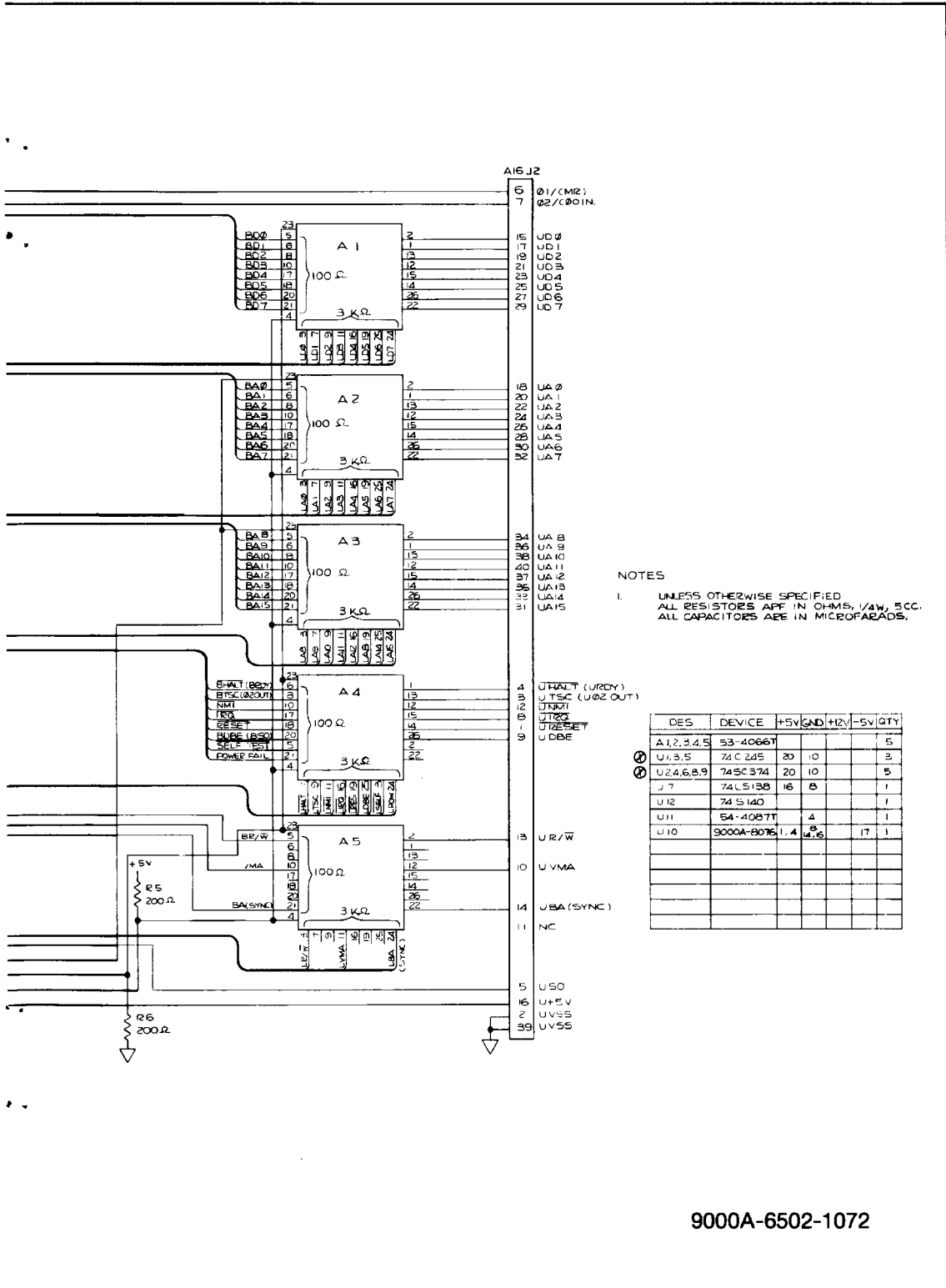

Figure 7-2. A16 Interface PCB Assembly