

9010A

Micro-System Troubleshooter

Service Manual



NOTE

This manual documents Model 9010A and its assemblies at the revision levels shown in Appendix 7A. If your instrument contains assemblies with different revision letters, it will be necessary for you to either update or backdate this manual. Refer to the supplemental change/errata sheet for newer assemblies, or to the backdating sheet in Appendix 7A for older assemblies.

9010A

Micro-System

Troubleshooter

Service Manual

P/N 609297
APRIL 1982

©1982, John Fluke Mfg. Co., Inc., all rights reserved. Litho in U.S.A.



WARRANTY

Notwithstanding any provision of any agreement the following warranty is exclusive:

The JOHN FLUKE MFG. CO., INC., warrants each instrument it manufactures to be free from defects in material and workmanship under normal use and service for the period of 1-year from date of purchase. This warranty extends only to the original purchaser. This warranty shall not apply to fuses, disposable batteries (rechargeable type batteries are warranted for 90-days), or any product or parts which have been subject to misuse, neglect, accident, or abnormal conditions of operations.

In the event of failure of a product covered by this warranty, John Fluke Mfg. Co., Inc., will repair and calibrate an instrument returned to an authorized Service Facility within 1 year of the original purchase; provided the warrantor's examination discloses to its satisfaction that the product was defective. The warrantor may, at its option, replace the product in lieu of repair. With regard to any instrument returned within 1 year of the original purchase, said repairs or replacement will be made without charge. If the failure has been caused by misuse, neglect, accident, or abnormal conditions of operations, repairs will be billed at a nominal cost. In such case, an estimate will be submitted before work is started, if requested.

THE FOREGOING WARRANTY IS IN LIEU OF ALL OTHER WARRANTIES, EXPRESS OR IMPLIED, INCLUDING BUT NOT LIMITED TO ANY IMPLIED WARRANTY OF MERCHANTABILITY, FITNESS, OR ADEQUACY FOR ANY PARTICULAR PURPOSE OR USE. JOHN FLUKE MFG. CO., INC., SHALL NOT BE LIABLE FOR ANY SPECIAL, INCIDENTAL, OR CONSEQUENTIAL DAMAGES, WHETHER IN CONTRACT, TORT, OR OTHERWISE.

If any failure occurs, the following steps should be taken:

1. Notify the JOHN FLUKE MFG. CO., INC., or nearest Service facility, giving full details of the difficulty, and include the model number, type number, and serial number. On receipt of this information, service data, or shipping instructions will be forwarded to you.
2. On receipt of the shipping instructions, forward the instrument, transportation prepaid. Repairs will be made at the Service Facility and the instrument returned, transportation prepaid.

SHIPPING TO MANUFACTURER FOR REPAIR OR ADJUSTMENT

All shipments of JOHN FLUKE MFG. CO., INC., instruments should be made via United Parcel Service or "Best Way"™ prepaid. The instrument should be shipped in the original packing carton; or if it is not available, use any suitable container that is rigid and of adequate size. If a substitute container is used, the instrument should be wrapped in paper and surrounded with at least four inches of excelsior or similar shock-absorbing material.

CLAIM FOR DAMAGE IN SHIPMENT TO ORIGINAL PURCHASER

The instrument should be thoroughly inspected immediately upon original delivery to purchaser. All material in the container should be checked against the enclosed packing list. The manufacturer will not be responsible for shortages against the packing sheet unless notified immediately. If the instrument is damaged in any way, a claim should be filed with the carrier immediately. (To obtain a quotation to repair shipment damage, contact the nearest Fluke Technical Center.) Final claim and negotiations with the carrier must be completed by the customer.

The JOHN FLUKE MFG. CO., INC., will be happy to answer all applications or use questions, which will enhance your use of this instrument. Please address your requests or correspondence to: JOHN FLUKE MFG. CO., INC., P.O. BOX C9090, EVERETT, WASHINGTON 98206, ATTN: Sales Dept. For European Customers: Fluke (Holland) B.V., P.O. Box 5053, 5004 EB, Tilburg, The Netherlands.

*For European customers, Air Freight prepaid.

John Fluke Mfg. Co., Inc., P.O. Box C9090, Everett, Washington 98206

Table of Contents

SECTION	TITLE	PAGE
1	INTRODUCTION AND SPECIFICATIONS	1-1
	1-1. THE 9010A INSTRUCTION MANUAL SET	1-1
	1-4. INSTRUMENT DESCRIPTION	1-1
	1-6. LIST OF RECOMMENDED TEST EQUIPMENT	1-2
	1-8. SPECIFICATIONS	1-2
2	SHIPPING AND SERVICE INFORMATION	2-1
	2-1. SHIPPING INFORMATION	2-1
	2-7. QUESTIONS/PROBLEMS	2-1
3	THEORY OF OPERATION	3-1
	3-1. INTRODUCTION	3-1
	3-3. OVERALL BLOCK DIAGRAM DESCRIPTION	3-1
	3-4. Interface Pod Function	3-1
	3-8. Troubleshooter Organization	3-1
	3-11. Immediate Mode Operation	3-4
	3-17. Programming Mode Operation	3-4
	3-19. Executing Mode Operation	3-4
	3-21. Probe Logic Function	3-4
	3-25. Signature Generator/Event Counter Function	3-5
	3-28. Magnetic Tape Controller Function	3-5
	3-30. RS-232 Interface Function (Option -001)	3-5
	3-32. DETAILED BLOCK DIAGRAM DESCRIPTION	3-5
	3-33. Introduction	3-5
	3-35. Control Section	3-5
	3-48. Display/Keyboard Assembly	3-8
	3-67. Pod/Probe PIA	3-11
	3-71. Pod Communication	3-11
	3-75. Probe Logic	3-11
	3-101. Signature Generator and Event Counter	3-16
	3-105. Magnetic Tape Controller	3-17
4	MAINTENANCE	4-1
	4-1. INTRODUCTION	4-1
	4-3. GENERAL INFORMATION	4-1
	4-4. Access Information	4-1
	4-6. Cleaning	4-1
	4-9. FUSE REPLACEMENT	4-1
	4-10. Line Fuse	4-1
	4-12. Probe Fuse	4-1
	4-14. PERFORMANCE TEST	4-2
	4-15. Self Test	4-2

TABLE OF CONTENTS, *continued*

SECTION	TITLE	PAGE
4-19.	Probe Level Detection/Verification	4-5
4-21.	Probe Pulser Checks	4-5
4-23.	Magnetic Tape Check	4-5
4-25.	Pod Connector Checks	4-5
4-27.	Display/Keyboard Check	4-5
4-29.	CALIBRATION ADJUSTMENTS	4-5
4-30.	Power Supply Adjustment	4-5
4-32.	Magnetic Tape Speed Adjustment	4-5
4-34.	Probe Input Compensation Adjustment	4-7
4-36.	REPAIR PRECAUTIONS	4-7
4-37.	TROUBLESHOOTING	4-8
4-38.	Introduction	4-8
4-40.	Power Supply Checks	4-8
4-44.	Bus/RAM/ROM Checks	4-8
4-46.	I/O Selector Checks	4-10
4-49.	Power-On Reset/Watchdog Timer Checks	4-10
4-51.	Pod/Probe PIA Checks	4-11
4-53.	Probe Related Circuit Checks	4-11
4-66.	Signature Register Checks	4-21
4-68.	Event Counter Checks	4-21
4-70.	Display/Keyboard Checks	4-21
5	LIST OF REPLACEABLE PARTS	5-1
	TABLE OF CONTENTS	5-1
5-1.	INTRODUCTION	5-2
5-4.	HOW TO OBTAIN PARTS	5-2
6	OPTION AND ACCESSORY INFORMATION	6-1
	TABLE OF CONTENTS	6-1
7	GENERAL INFORMATION	7-1
7A	MANUAL CHANGE INFORMATION	7A-1
8	SCHEMATIC DIAGRAMS	8-1
	TABLE OF CONTENTS	8-1

List of Tables

TABLE	TITLE	PAGE
1-1.	Required Test Equipment	1-2
1-2.	9010A Specifications	1-2
4-1.	Self Test Failure Codes	4-3
4-2.	Display Performance Test	4-5
4-4.	Memory Addresses and Signatures	4-10
4-5.	DIA (U22) Test	4-12
4-6.	Free Running Probe Check	4-15
4-7.	Synchronized Probe Check	4-18
4-8.	Probe Pulse Output Check	4-19
4-9.	Signature Register Test	4-22
4-10.	Event Counter Test	4-23
4-11.	Keyboard Switch Identification	4-25
4-12.	Display/Keyboard Communication Check	4-27
4-13.	Memory and I/O Device Addressing and Commands	4-32

List of Illustrations

FIGURE	TITLE	PAGE
Frontispiece	9010A Micro-System Troubleshooter	vi
1-1.	9010A Outline Drawing	1-5
3-1.	Connection of Troubleshooter to UUT	3-2
3-2.	General Block Diagram	3-3
3-3.	Control Section	3-7
3-4.	Control Section Signals	3-8
3-5.	Display/Keyboard Assemblies	3-10
3-6.	Pod/Probe PIA Signals	3-12
3-7.	MAINSTAT/PODSTAT Signals	3-12
3-8.	Probe Logic	3-13
3-9.	Probe Fuse Sensing Circuit	3-15
3-10.	Signature Register/Event Counter	3-16
3-11.	Magnetic Tape Controller	3-18
3-12.	Tape Data Ratio Coding	3-19
4-1.	Line Fuse Replacement	4-2
4-2.	Probe Fuse Location	4-3
4-3.	Asynchronous Input Values	4-5
4-4.	Power Supply Test Points and Adjustments	4-6
4-5.	Tape Speed Adjustments	4-7
4-6.	Probe Component Test Points and Adjustments	4-8
4-7.	Main Assembly Components	4-9
4-8.	Display/Keyboard Self-Test Points	4-24
4-9.	Keyboard Test Pattern	4-25
4-10.	Read Test Waveforms	4-30
4-11.	Write Test Waveforms	4-31

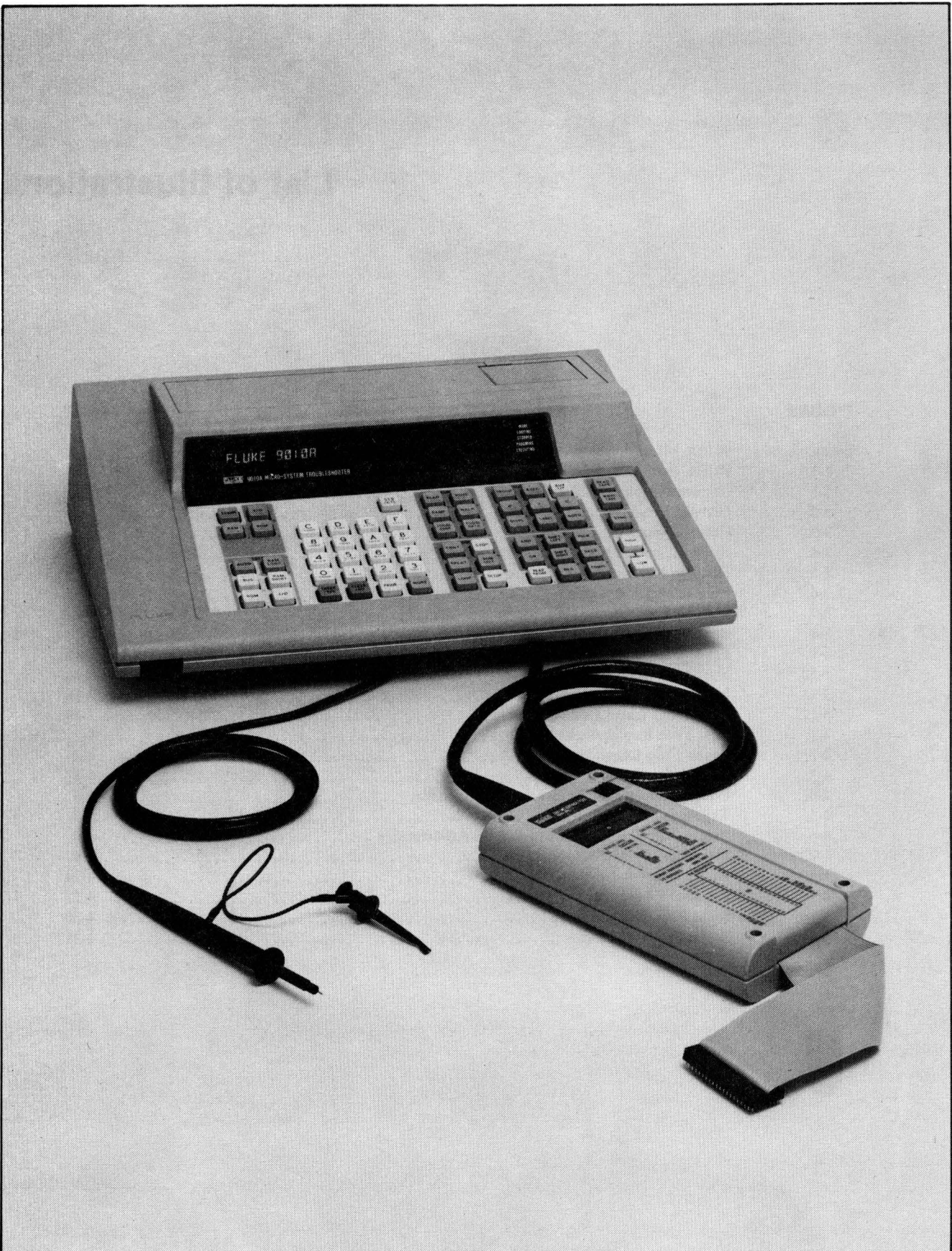

9010A Micro-System Troubleshooter

Section 1

Introduction and Specifications

WARNING

THESE SERVICING INSTRUCTIONS ARE FOR USE BY QUALIFIED PERSONNEL ONLY. TO AVOID ELECTRICAL SHOCK, DO NOT PERFORM ANY SERVICING OTHER THAN THAT CONTAINED IN THE OPERATOR MANUAL UNLESS YOU ARE QUALIFIED TO DO SO.

1-1. THE 9010A INSTRUCTION MANUAL SET

1-2. The Fluke Model 9010A Micro System Troubleshooter is documented by a set of three manuals and a reference guide, all described below:

Operator Manual

Provides instrument description and specifications, operating instructions including troubleshooting and test techniques, probe useage, execution of programs, options and accessories, and routine operator maintenance.

Programming Manual

Provides description of instrument programming capabilities; writing, editing, and execution of programs. Little or no experience is required to program the 9010A.

Service Manual

Provides specifications, theory of operation, troubleshooting, repair/maintenance information, disassembly procedures, a list of replaceable parts, and schematic diagrams. Intended for use by qualified service personnel.

Reference Guide

Quick-reference operating and programming information.

1-3. In addition, an Interface Pod Manual is provided with each interface pod. The pod manual contains the following information:

Interface Pod Manual

Provides specifications, microprocessor data, status and control line identification information, interface pod operating characteristics, theory of operation, troubleshooting procedures, disassembly information, a list of replaceable parts, and schematic diagrams.

1-4. INSTRUMENT DESCRIPTION

1-5. The 9010A Microsystem troubleshooter is a portable service instrument for testing and troubleshooting microprocessor-based equipment. The 9010A provides the following features:

- Keyboard selection of functions and operating modes.
- 32-character display for presentation of test results, operator messages, and prompts.
- Single-keystroke validation of electrical integrity of uP bus.
- Learn function for mapping UUT (unit under test) address space and identifying RAM, ROM, and I/O.
- Comprehensive, functional testing of RAM, ROM, and I/O.
- Nine troubleshooting functions for troubleshooting on or off the bus.

- On-line programming for development of system test and fault isolation programs.
- Consistent prompts and defaults for easy selection and specification of operations.
- Detailed error messages for locating UUT failures.
- Dual-function stimulus/response probe for generating bus-synchronized pulses or gathering signatures, counting events, and detecting logic levels.
- Hexadecimal keyboard for data entry.
- Sixteen 32-bit internal registers for storage and manipulation of data.
- Built-in cassette recorder for nonvolatile storage and transfer of test programs and data on minicassettes.
- Optional RS-232 port for remote communication.
- Optional interface pods for interfacing with most off-the-shelf microprocessors.
- UUT microprocessor emulation for execution of UUT program code.
- Rear-panel scope trigger output synchronized to UUT microprocessor bus events.

1-6. LIST OF RECOMMENDED TEST EQUIPMENT

1-7. Table 1-1 lists the test equipment required to complete the adjustment and troubleshooting procedures described in Section 4 of this manual. Equivalent equipment, if available, may be used in place of the recommended models.

1-8. SPECIFICATIONS

1-9. Specifications for the 9010A are listed in Table 1-2. The dimensions of the 9010A are shown in Figure 1-1.

Table 1-1. Required Test Equipment

INSTRUMENT TYPE	RECOMMENDED MODEL
Micro System Troubleshooter	Fluke 9010A
Interface Pod	Fluke 9000A-Z80
Digital Multimeter	Fluke 8020, 0.1%
Oscilloscope	Tektronix 485 or equivalent
Storage Oscilloscope	Tektronix 7623A w/7A18 plug-in
Variable Dc Power Supply	Any 0-10V Model

Table 1-2. 9010A Specifications

DISPLAY	32 character, 14 segment alphanumeric with decimal points.
KEYBOARD FUNCTIONS	
Data Entry	16-Key hexadecimal keyboard (0 through 9, A through F) for entering data.
ENTER/YES	Used for terminating expressions, responding to questions.
CLEAR/NO	Used for terminating expressions, responding to questions, deleting unwanted input.
Mapping UUT Memory	
LEARN	Locates and identifies RAM, and I/O read-write registers. Computes ROM signatures and identifies read/writable I/O bits.
Viewing UUT Memory	
VIEW RAM, VIEW ROM, VIEW I/O	Allows viewing or editing of UUT address space information.

Table 1-2. 9010A Specifications (cont)

Functional Tests

BUS TEST	Checks electrical integrity of UUT microprocessor bus.
ROM TEST	Computes ROM signature and compares to specified ROM signature.
I/O TEST	Checks read-write capability of I/O registers.
RAM SHORT	Checks read-write capability and decoding of RAM locations.
RAM LONG	Checks bit pattern sensitive failures using an expanding checker-board pattern on RAM locations as well as those tests performed by RAM short test.
AUTO TEST	Performs in sequence BUS TEST, ROM TEST, RAM SHORT and I/O TEST.

Troubleshooting Functions

READ	Reads from UUT at an operator-specified address and reports value read.
WRITE	Writes operator-specified data to an operator-specified UUT address.
RAMP	Writes a binary incrementing pattern to an operator-specified UUT address.
WALK	Writes a rotating operator-specified bit pattern to the data lines at an operator-specified UUT address.
TOGGL DATA	Toggles an operator-specified data bit at a UUT address from one binary logic state to the other.
TOGGL ADDR	Toggles an operator-specified UUT address bit from one binary logic state to the other.
READ STS	Reads and displays the values of the UUT microprocessor status lines.
WRITE CTL	Writes operator-specified values to control lines on the UUT microprocessor bus.
TOGGL DATA CTL	Toggles an operator-specified control line from one binary logic state to another.

Mode Controls

CONT	Continues an interrupted operation (operations are typically interrupted to report errors).
STOP	Halts current 9010A operation.
RPEAT	Repeats the previously performed 9010A operation once.
LOOP	Continuously performs the previous operation.
RUN UUT	Executes UUT program code beginning at an operator-specified address.

Editing

MORE	Advances display to next line of information or next program step.
PRIOR	Scrolls display to previous line of information or prior program step.

Test Sequencing Eight functions for entering or executing programs, and creating program messages, branches and loops.

Arithmetic Eight functions for performing arithmetic on numeric quantities and manipulating data in registers.

Table 1-2. 9010A Specifications (cont)

Selecting UUT-Specific Operations	
SETUP	Allows the operator to select specific 9010A error detection and operating features to meet the requirements of a particular UUT.
Cassette Tape Operations	
READ TAPE	Reads information from cassette tape into 9010A memory.
WRITE TAPE	Writes information from 9010A memory onto cassette tape.
Probe Controls	
SYNC	Allows specification of probe synchronization to UUT bus events.
HIGH and LOW	Control generation of stimuli by the probe.
READ PROBE	Gathers response information at probe tip and displays signature, logic state history, and event count.
RS-232 Interface Option Control	
AUX I/F	Controls transfer of data over RS-232 Interface (if installed).
CASSETTE TAPE	Minicassettes store UUT memory map information, setup parameters, and program. Minicassette type: Verbatim.
PROBE	
General	Single-point stimulus and response probe.
STIMULUS	Pulse high, low, or toggle between high and low.
RESPONSE	Signature computation, logic states detected, event count.
Stimulus Mode	
STIMULUS PULSE WIDTH	
Address or data-valid sync	Equals address-valid or data-valid interval of the interface pod μ P.
Free-run	2 μ sec nominal.
STIMULUS PULSE AMPLITUDE	
High	>4V at +100 mA
Low	<0.2V at -100 mA
Response Mode	
INDICATOR THRESHOLD	
Logic High (Red)	>2.4V
Logic Low (Green)	<0.8V
Logic Tristate	<2.4V and >0.8V
INDICATOR THRESHOLD ACCURACY .	\pm 0.2V
INDICATOR MINIMUM PULSE WIDTH	
Logic High	>75 ns
Logic Tristate	>100 ns
Logic Low	>75 ns
Maximum Safe Input Voltage at Probe Tip .	-30V dc to +30V dc
Probe Fuse	The ground clip used with the probe is protected by a series-connected fuse located adjacent to the probe connector. A blown fuse is sensed by the 9010A and reported by a message on the display.

Table 1-2. 9010A Specifications (cont)

9010A OPERATOR-ACCESSIBLE MEMORY	
Tape-Transferable Memory	Approximately 12k bytes for storage of UUT memory map information, Setup parameters, and programs. Contents may be transferred to and from cassette tape or transferred to and from a remote device via the RS-232 Interface Option.
Registers	Sixteen 32-bit registers.
GENERAL	
Power Requirements	100, 120, 220 or 240V ac $\pm 10\%$ 50 or 60 Hz $\pm 5\%$ 40 Watts maximum
Size	11.7x38.7x31.1cm. (HXWXL) (4.6x15.25x12.25in.) See Figure 1-2.
Weight	5 kg. (11 lb.)
Environmental	
STORAGE TEMPERATURE	
Without Cassette Tape	-40 to +70°C (RH <95%)
With Cassette Tape	+4 to 50°C (10% to 90% RH)
OPERATING TEMPERATURE	
Without Cassette Tape	0 to 25°C (RH <95%) 25 to 40°C (RH <75%) 40 to 50°C (RH <45%)
With Cassette Tape	10 to 25°C (20% to 80% RH) 25 to 30°C (20% to 73% RH) 30 to 35°C (20% to 49% RH) 35 to 40°C (20% to 32% RH)
<i>NOTE: All relative humidity (RH) conditions are non-condensing.</i>	

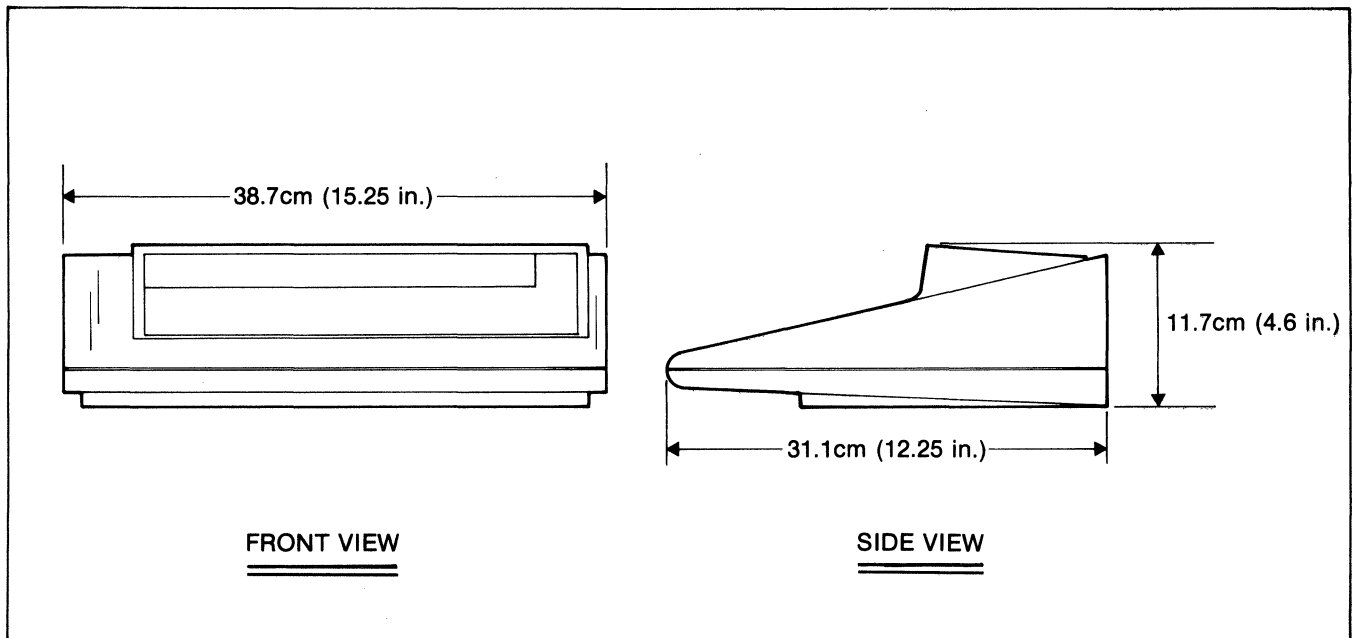

Figure 1-1. 9010A Outline Drawing

Section 2

Shipping and Service Information

2-1. SHIPPING INFORMATION

2-2. The 9010A is packed and shipped in a foam-packed container. When you receive the 9010A, inspect the instrument thoroughly for possible shipping damage. Special instructions for inspection and claims are included with the shipping container.

2-3. If reshipment is necessary, use the original container. If the original container is not available, order a new one from John Fluke Mfg. Co., Inc. P.O. Box C9090, Everett, WA 98206. Telephone (206) 342-6300

2-4. SERVICE INFORMATION

2-5. Each Fluke Model 9010A Micro System Troubleshooter is warranted for a period of one year

upon delivery to the original purchaser. A copy of the WARRANTY is located at the front of this manual.

2-6. Factory authorized calibration and service for each Fluke product is available at various worldwide locations. Section 7 contains a complete list of these service centers. If requested, the customer will be provided with an estimate before any work begins on instruments that are beyond the warranty period.

2-7. QUESTIONS/PROBLEMS

2-8. For additional information, contact your nearest Fluke Sales Representatives (see Section 7) or the John Fluke Mfg. Co., Inc. at the address or telephone given in the Shipping Information.

Section 3

Theory of Operation

3-1. INTRODUCTION

3-2. This section presents the theory of operation for the 9010A on a general block diagram level, followed by more detailed block diagram descriptions of each portion of the instrument.

3-3. OVERALL BLOCK DIAGRAM DESCRIPTION

3-4. Interface Pod Function

3-5. The main function of the troubleshooter is to diagnose problems within any bus-oriented microprocessor based equipment. As shown in Figure 3-1, the troubleshooter is connected to the unit under test (UUT) via its microprocessor socket and a matching interface pod. The interface pod is compatible with the pin layout, the status/control functions, interrupt handling, and timing for the particular microprocessor employed by the unit under test.

3-6. In order to perform tests on a UUT, the troubleshooter issues commands and address information to the interface pod. Each troubleshooter command causes the microprocessor within the pod to execute a corresponding routine contained in its ROM. The routine, when executed within the interface pod, performs the commanded functions, such as a read or a write to the UUT at the specified address.

3-7. In short, the troubleshooter issues a basic command, and the interface pod performs the actual operation in a manner compatible with the microprocessor type employed by the UUT. For a complete description of interface pod operation, refer to the particular Interface Pod Manual.

3-8. Troubleshooter Organization

3-9. The troubleshooter is a microprocessor-based system, complete with 16K bytes of RAM and several I/O devices, including a magnetic tape unit and an optional communications interface. The general block diagram of

the instrument, presented in Figure 3-2, shows the internal organization of the instrument. The microprocessor initiates and controls all troubleshooter operations under the direction of firmware contained in ROM. The microprocessor views the RAM and ROM as memory devices, and views the following as I/O devices:

- Pod/Probe PIA (peripheral interface adapter)
- Display/Keyboard Assembly
- Signature Generator and Event Counter Circuit
- Magnetic Tape Controller
- RS-232 Interface (Option -001)

3-10. The microprocessor, in conjunction with the RAM, the ROM, the I/O selector, and the address and data buses, service each I/O device as required to:

- Issue commands and address data to the interface pod.
- Receive read data and status information from the interface pod.
- Receive keyboard data (operator commands) from the display/keyboard assembly.
- Send display data to the display assembly.
- Turn the probe pulse circuitry on or off.
- Receive signatures and/or event counts generated by the signature generator and event counter circuit from data at the probe tip.
- Write programs and test data stored in RAM to the magnetic tape unit for future use.

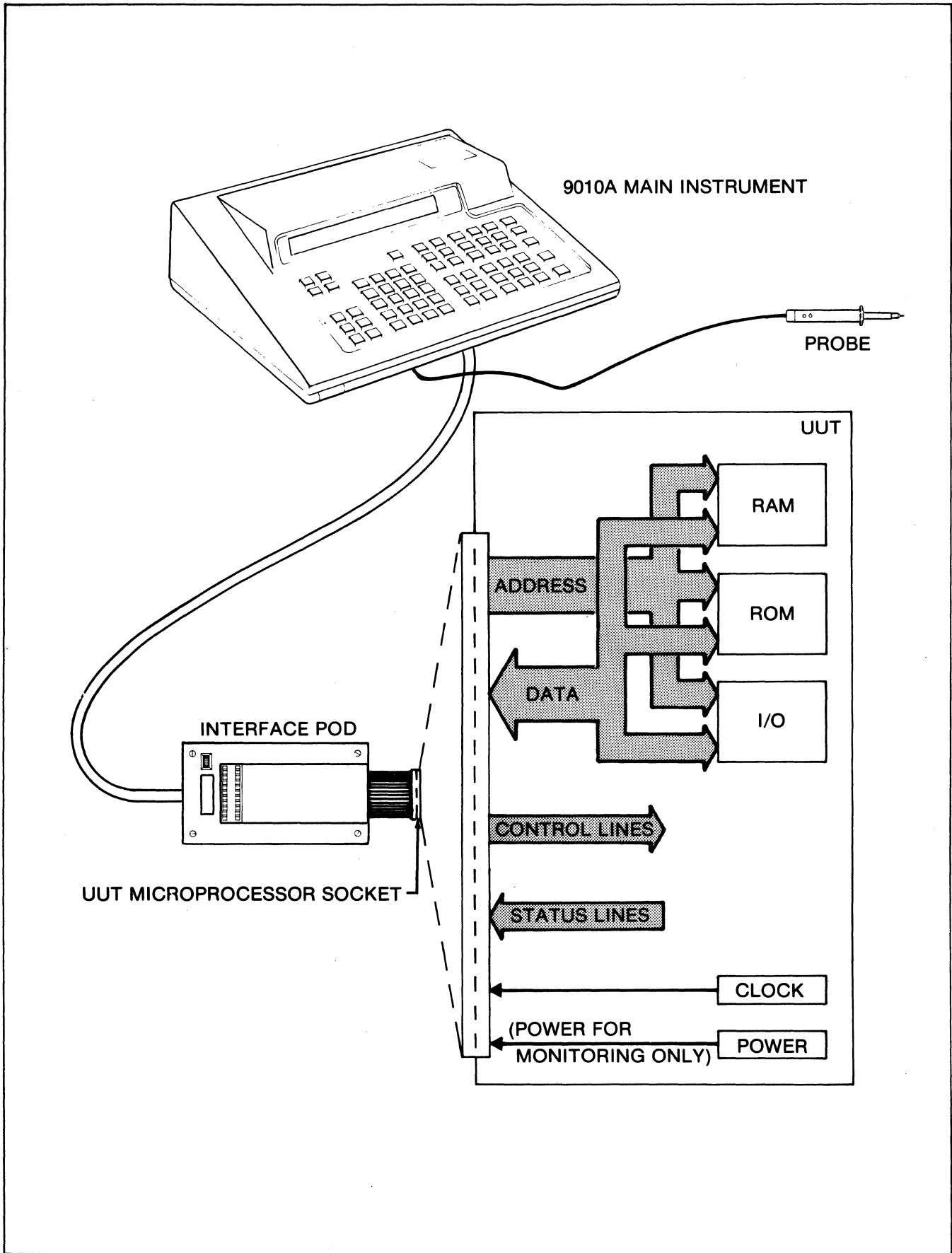

Figure 3-1. Connection of Troubleshooter to UUT

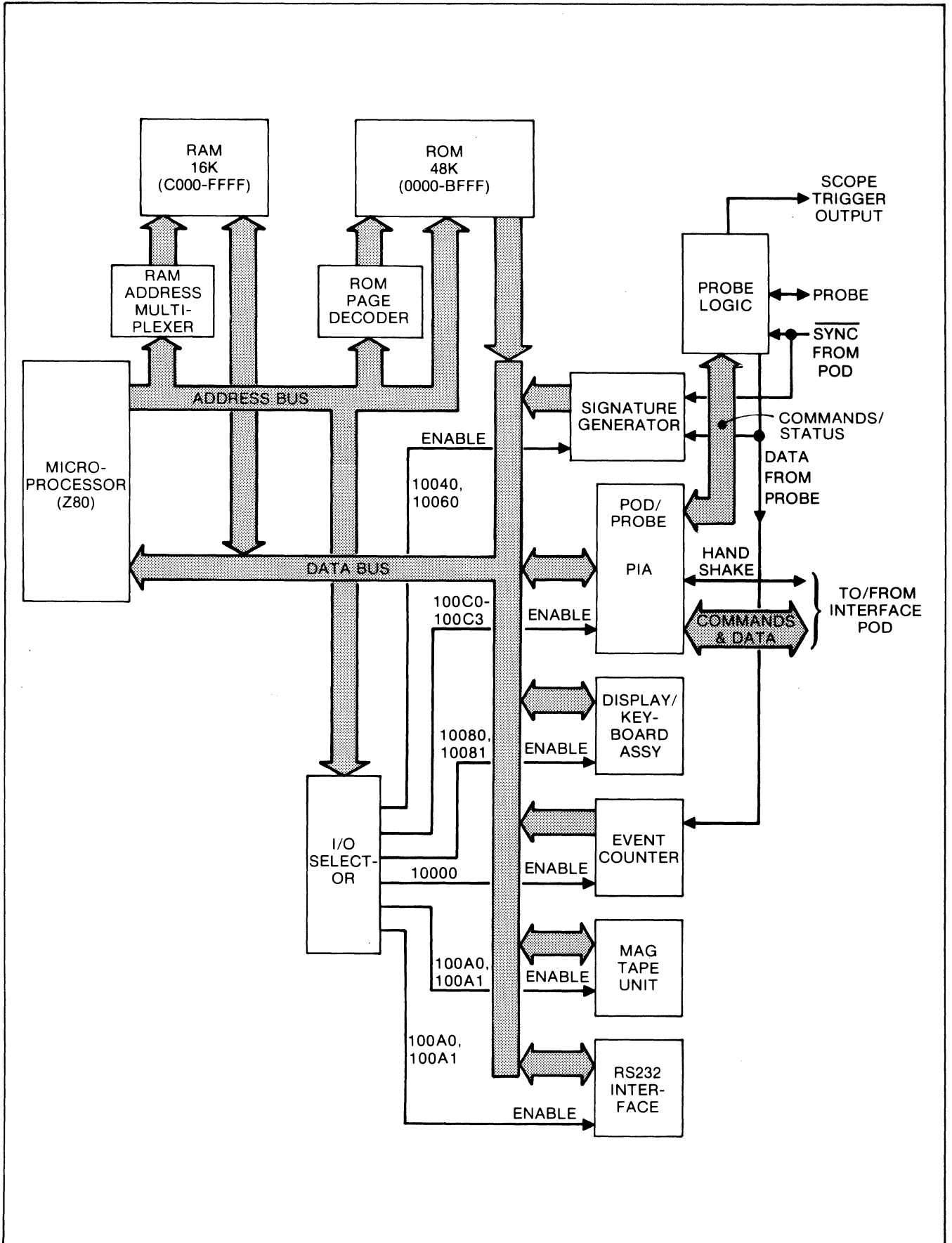

Figure 3-2. General Block Diagram

- Read programs and test data from the magnetic tape unit to RAM for immediate use.
- Send address space information, setup information, any or all programs, program numbers, or all information contained in tape-transferable memory to some remote device via the RS-232 interface.
- Receive data from a remote 9010A or computer via the RS-232 interface.

3-11. Immediate Mode Operation

3-12. When operating the troubleshooter in the immediate mode, the microprocessor routinely addresses (by means of the I/O selector) the Display/Keyboard Assembly for keyboard commands initiated by the operator. When the operator presses a key, the Display/Keyboard Assembly generates an 8-bit byte of keyboard data which corresponds to the key pressed. When addressed by the microprocessor, the Display/Keyboard Assembly places the byte of keyboard data on the data bus. The microprocessor reads the keyboard data and determines the key pressed. The microprocessor then takes appropriate action by sending a corresponding message to the Display/Keyboard Assemblies and prepares to receive subsequent keyboard data from the same.

3-13. For example, when the operator presses the READ key, and the microprocessor routinely addresses the Display/Keyboard Assembly, the Display/Keyboard Assembly places the 8-bit data byte corresponding to the READ key on the data bus. The microprocessor reads the 8-bit byte and determines that the READ key is pressed: it then sends the message READ @ _ to the display, prompting the operator for address information.

3-14. As the operator enters the read address, the microprocessor reads each byte of address data at the Display/Keyboard Assembly. The microprocessor then assembles the read address by writing each byte to a designated portion of RAM. When the operator completes the entry of the read address and presses the ENTER key, the microprocessor assumes completion of address entry. The microprocessor then addresses the pod/probe PIA and issues a read command to the pod, using the address assembled from the operator entry. The pod accepts the read command and address data then performs the actual read operation with the UUT.

3-15. Shortly after issuing the read command to the pod via the pod/probe PIA, the microprocessor routinely addresses the pod/probe PIA for the response data (the data read at the UUT location specified in the read command). As the pod sends each byte of data, read from the UUT, to the pod/probe PIA, the microprocessor reads each byte and writes it to a designated portion of RAM. When the microprocessor completes the reading

of UUT data and writing to RAM, it addresses the Display/Keyboard Assembly and writes the data for display.

3-16. The preceding example illustrates general operation of the troubleshooter in the immediate mode. Most operations in the immediate mode are performed in a manner similar to that described for a typical read operation. As the operator presses specific keys in order to select specific functions, the microprocessor performs corresponding tasks in order to complete the functions.

3-17. Programming Mode Operation

3-18. Operation of the troubleshooter in the programming mode is similar to that described for the immediate mode in that the operator presses specific function keys and enters data when prompted by the microprocessor display. Similarity of operation continues up to the point of pressing the ENTER key. When the operator presses the ENTER key to terminate entry of a command, the microprocessor stores the command in RAM as a step of a program instead of immediately issuing it to the interface pod. Execution of the stored step takes place when the program in which it resides is executed.

3-19. Executing Mode Operation

3-20. Operation of the troubleshooter in the executing mode is similar to that described for the immediate mode except for the lack of keyboard function. In the executing mode, the microprocessor obtains commands and data previously stored in RAM as part of a program (during operation in the programming mode) instead of reading commands and data from entries made at the keyboard. The microprocessor executes each command stored in RAM as a step of a stored program.

3-21. Probe Logic Function

3-22. The operator selects the mode of probe operation by pressing the appropriate keyboard keys (READ PROBE, HIGH, LOW, or SYNC). The microprocessor reads the key closures at the output of the display/keyboard assembly via the data bus in a manner similar to that described in Immediate Mode Operation. In response to the user selecting a probe function at the keyboard, the microprocessor addresses the appropriate port of the pod/probe PIA and writes the corresponding probe command to the probe logic. The probe logic decodes the probe command and causes the probe to produce high and/or low pulses, either synchronized or unsynchronized with pod operation.

3-23. In addition to generating pulses, the probe logic also receives input signals from the probe. It determines whether or not the voltages at the probe tip fall within certain valid limits (refer to the specifications for voltage detection threshold) and lights the probe lamps accordingly.

3-24. A data byte which indicates the logic level at the probe tip, or any invalid voltage condition, is sent by the probe logic to the appropriate port of the pod/probe PIA. The microprocessor reads the data byte applied to the pod/probe PIA port, after execution of a READ PROBE command, and determines the logic state at the probe tip (high, low, or invalid). The microprocessor then writes the appropriate message to the display/keyboard assembly for display to the operator.

3-25. Signature Generator/Event Counter Function

3-26. The signature generator receives the signal data read by the probe and, in conjunction with the SYNC pulse from the pod, applies these signals to the data and clock inputs of the signature shift register. As a result, the shift register generates a signature unique to the incoming probe signal. The event counter maintains a running total of high-to-invalid transitions (events) read by the probe.

3-27. Pressing the READ PROBE key causes the microprocessor to address (by means of the I/O selector) the signature generator and event counter circuit and reads their contents. The microprocessor then writes the current contents to a designated portion of RAM (register 0). With the signature and event count stored in RAM, the microprocessor resets the signature generator and event counter circuit permitting the next read probe operation to accumulate and yield new probe data. If the read probe operation was performed in the immediate mode, the microprocessor also sends new probe-tip state data, probe signature, and event count data to the Keyboard/Display Assembly for display to the operator.

3-28. Magnetic Tape Controller Function

3-29. The Magnetic Tape Controller controls the magnetic tape unit in response to commands from the microprocessor. The Magnetic Tape Controller contains a peripheral microcomputer which, under internal software control, performs the following functions:

- Reads to or writes from the tape.
- Controls tape direction and speed.
- Rewinds tape.
- Positions tape at load point.
- Formats write words.
- Decodes read words.
- Detects end of tape.
- Detects cassette present/not present.
- Detects write-protected cassette.

- Detects synchronization errors.
- Reports magnetic tape controller status to the main microprocessor.

3-30. RS-232 Interface Function (Option -001)

3-31. The RS-232 Interface provides an EIA RS-232-C compatible bidirectional interface to the troubleshooter with selectable baud rates of 110, 150, 300, 600, 1200, 4800, and 9600. The interface is isolated from the troubleshooter and meets all RS-232 requirements for bidirectional movement of serial data. The RS-232 Interface provides communications to and from other 9000 series troubleshooters or other RS-232 compatible devices. Refer to Section 6 for the description of the RS-232 Interface.

3-32. DETAILED BLOCK DIAGRAM DESCRIPTION

3-33. Introduction

3-34. The following paragraphs describe operation of the troubleshooter at a detailed block diagram level. Each description includes a block diagram which can be related to the schematic diagrams contained in Section 8.

NOTE

Memory and I/O devices are controlled by addresses and, in some cases, by data. Table 4-13 lists controlling addresses and data.

3-35. Control Section

3-36. The control section of the troubleshooter, shown in block diagram Figure 3-3, contains the clock, the microprocessor, RAM, ROM, RFSH/RAM control, memory page selector, RAM address 2:1 multiplexer, power-on reset circuit and watchdog timer, and an I/O selector. The control section operates as a small computer system to initiate and control, by means of software contained in ROM, all troubleshooter and interface pod functions.

3-37. CLOCK CIRCUIT

3-38. The clock circuit, made up of G1, U34 and U30, provides timing control for the troubleshooter. The clock circuit contains a 6.5 MHz oscillator, the output of which is divided by two to produce a 3.25 MHz output. The 3.25 MHz is buffered and fed to the microprocessor, the RFSH/RAM control circuit, and flip-flop U32. (Flip-flop U32 produces a clock pulse to drive the pod/probe PIA each time an I/O operation takes place. Refer also to the pod/probe PIA description.)

3-39. MEMORY PAGE SELECTOR

3-40. When enabled by the logic signal RFSH•MREQ the memory page selector, U62, produces an enable signal to an addressed memory device while inhibiting all other memories. The memory page selector, a ROM, decodes

address lines A13, A14, and A15 to produce corresponding outputs and enable the memory devices in 8K byte pages. (See Table 4-13). In addition to enabling ROM devices located on the Main PCB Assembly, the memory page selector enables devices located on the Piggy-Back ROM Assembly when addressed by the microprocessor.

3-41. Address bus lines A0 - A13 connect to all memory devices. As a result, all memory devices receive the same address information. However, only the device enabled by the output of the memory page selector outputs data onto the data bus, D0 - D7. (The memory page selector also produces a valid RAM address, VRA, signal to the RFSH/RAM control circuit when the microprocessor addresses page 6 or 7, C000-FFFF, of memory.)

3-42. REFRESH/RAM CONTROL CIRCUIT

3-43. The function of the RFSH/RAM control circuit is to furnish the control signals required for proper operation of the dynamic RAM, U9 - U16. In addition to the clock signal, the RFSH/RAM control circuit, made up of U26, U28 and U29, also receives the $\overline{\text{RFSH}}$ (refresh) and $\overline{\text{MREQ}}$ (memory request) signals from the microprocessor.

3-44. The control signals required by the RAM allow the application of two different addresses (row and column) at the same RAM inputs, but at different times. The RAM (addresses C000 through FFFF) requires a row address followed by a column address in order to perform a read or write at a specific address. Before the microprocessor initiates a read or write operation, the $\overline{\text{RAS}}$ (row address strobe) and $\overline{\text{CAS}}$ (column address strobe) lines to the RAM are high, and the RE (row enable) line to the 2:1 multiplexer, U23 and U24, is low.

3-45. When the microprocessor initiates a RAM read or write operation, the memory page selector, U62, accepts the RAM address placed on lines A13, A14, and A15 and produces a memory page 6 or page 7 output. The page 6 or 7 outputs produce the VRA (valid RAM address) signal which enables the RFSH/RAM control circuit to produce a low-going $\overline{\text{RAS}}$ signal. The $\overline{\text{RAS}}$ signal causes the RAM to accept the output (A0' - A6') of the 2:1 multiplexer as the row address. Figure 3-4 shows the relationship of microprocessor signals used during RAM operations.

3-46. The 2:1 multiplexer accepts address lines A0 - A13 and selects either A0 - A6 or A7 - A13 for connection to the address inputs of the RAM, depending upon the state of the RE signal. A low RE signal causes the 2:1 multiplexer to connect address bus lines A0 - A6 to the RAM. A high RE signal causes the 2:1 multiplexer to connect address bus lines A7 - A13 to the RAM. With the RE signal initially low, address bus lines A0 - A6, which contain the RAM row address, are connected to the address inputs of the RAM at the time of the $\overline{\text{RAS}}$ signal.

3-47. One-half a clock cycle after a $\overline{\text{RAS}}$ pulse, the RFSH/RAM control circuit produces a high RE signal. The high RE signal causes the 2:1 multiplexer to connect address bus lines A7 - A13, which contain the RAM column address, to the address inputs of the RAM. One-half cycle after the RE signal goes high, the low-going $\overline{\text{CAS}}$ signal causes the RAM to accept the multiplexer output (A0 - A6) as the column address.

3-48. During the refresh portion of the microprocessor fetch cycle, the microprocessor applies a refresh address to the lowest seven address lines. These address lines are in-turn applied to the RAM devices via 2:1 multiplexer since the RE signal is low during the refresh cycle. The microprocessor changes this address each fetch cycle until all 128 rows are addressed and then repeats the cycle. During refresh, the RFSH/RAM control circuit produces only the $\overline{\text{RAS}}$ and RE signals, with the $\overline{\text{CAS}}$ signal inhibited as a result of the RFSH signal from the microprocessor.

3-49. I/O SELECTOR

3-50. Several portions of the troubleshooter are viewed by the microprocessor as I/O devices, and are addressed and serviced accordingly. Portions of the troubleshooter which appear as I/O devices are:

- Display/Keyboard Assembly
- Pod/Probe PIA
- Signature Generator and Event Counter
- Magnetic Tape Unit
- RS-232 Interface (Option -001)

3-51. As indicated in the lower portion of Figure 3-3, each I/O device connects to the data bus (D0 - D7), address line A0, and also to the Reset line. In addition, each I/O device receives an enable signal from the I/O selector, U25, except the signature generator and event counter circuit which may receive any one of four enable signals. (Refer to Table 4-13 for specific I/O addresses.)

3-52. The I/O selector is a 3-to-8 line decoder which accepts address bus lines A5, A6, and A7 when enabled by the low $\overline{\text{IOREQ}}$ (I/O request) output of the microprocessor. Whenever the microprocessor performs an I/O operation, it places the device address on the address bus and pulls the $\overline{\text{IOREQ}}$ output low. The I/O selector produces an output to select the addressed I/O device. While selected, the I/O device can receive and/or send data over the data bus as directed by the microprocessor. Each I/O device also receives the $\overline{\text{RESET}}$ signal from the power-on reset circuit and watchdog timer.

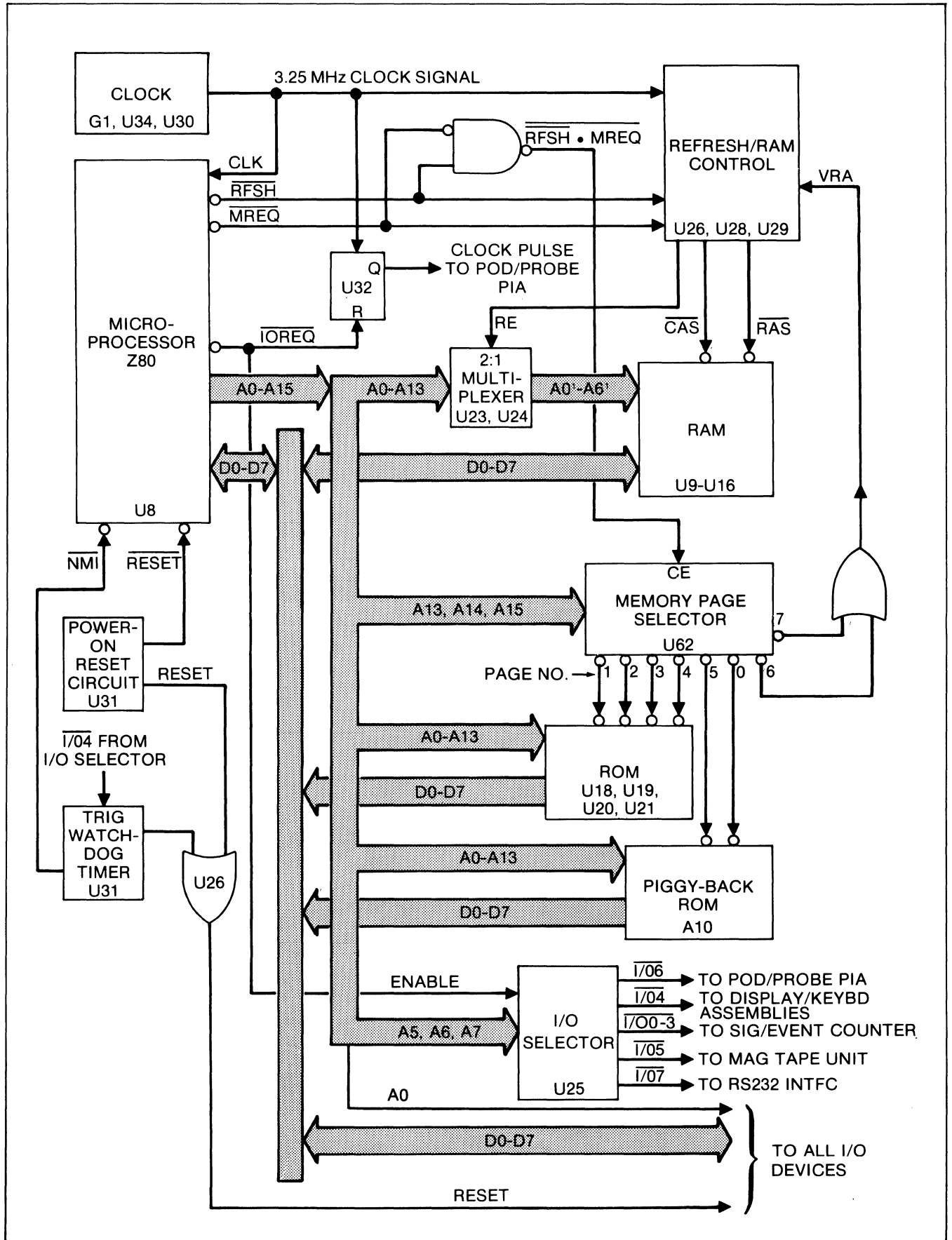

Figure 3-3. Control Section

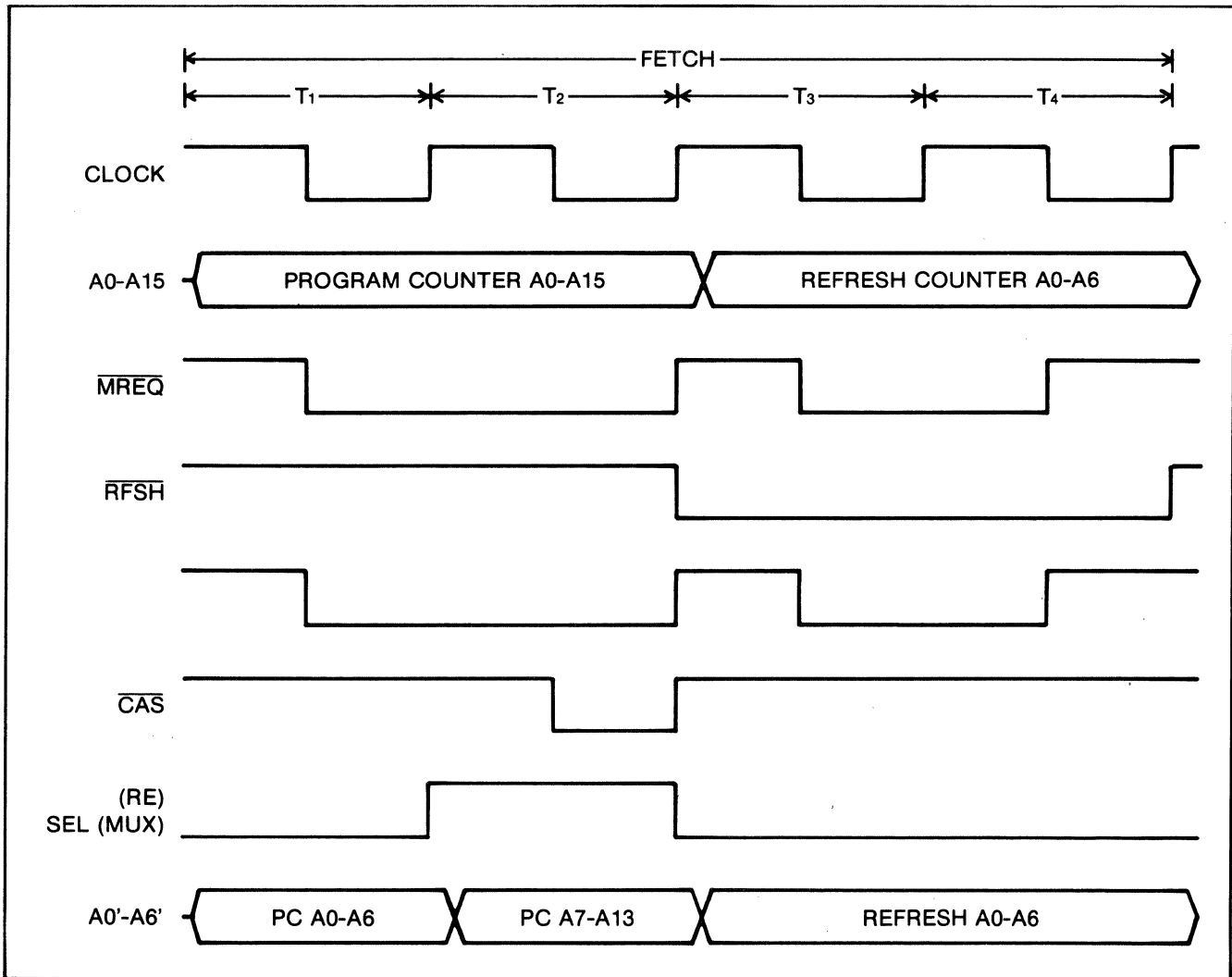

Figure 3-4. Control Section Signals

3-53. POWER-ON RESET CIRCUIT

3-54. The power-on reset circuit controls the resetting (initializing) of the microprocessor and each I/O device when power is applied to the troubleshooter. The power-on reset circuit consists of a one-shot which, upon the application of instrument power, generates a **RESET** and **RESET** signal. The **RESET** signal is fed to the **RESET** input of the microprocessor, while the **RESET** signal is fed via U26 to each I/O device.

3-55. WATCHDOG TIMER

3-56. The function of the watchdog timer is to detect any abnormal operation of the troubleshooter and, if abnormal operation occurs, interrupt the microprocessor and reset each I/O device. The watchdog timer, a re-triggerable one-shot, receives the $\overline{I/O4}$ output from the I/O selector to the Display/Keyboard Assembly. As long as the troubleshooter is operating normally, addressing of the Display/Keyboard Assembly takes place at a frequency sufficient to keep the watchdog timer in the triggered state.

3-57. However, if a problem develops which prevents normal troubleshooter operation, addressing of the Display/Keyboard Assembly, and consequently the $\overline{I/O4}$ signal, will typically cease or become infrequent. As a result of the missing $\overline{I/O4}$ signals, the watchdog timer times out before being retriggered, to produce a **RESET** signal to each I/O device (via U26), and an **NMI** (non-maskable interrupt) signal to interrupt the microprocessor. When interrupted, the microprocessor initiates a self test sequence to verify operation and writes the appropriate message to the Display/Keyboard Assembly.

3-58. Display/Keyboard Assembly

3-59. The Display/Keyboard Assembly operates as a complete subsystem of the control section to:

- Receive display data from the control section.
- Decode ASCII characters into 14-segment character codes.

- Continually refresh the troubleshooter display including annunciators.
- Monitor the keyboard for switch closures.
- Translate key closures into appropriate ASCII codes.
- Place keyboard data on the data bus.

3-60. The microprocessor in the control section transmits display data to this subsystem as necessary to create the appropriate troubleshooter messages, and frequently polls for keyboard data. As shown in Figure 3-5, the main elements of the Display/Keyboard Assembly include:

- An 8-bit peripheral microcomputer, U1
- A 32-character display, V1
- A 32-bit character shift register, U3 - U6
- Segment shift registers, U13 and U14
- Segment drivers, U11 and U12
- A keyboard, A3
- An 8-bit row shift register, U2
- A set of annunciator latches, U15
- A set of annunciators, DS1 - DS5
- Filament drive circuit, U16, U17, Q1 and Q2

3-61. The troubleshooter display is a 14-segment, 32-character, vacuum fluorescent display having 14 commonly-connected segment and one decimal point enable lines and 32 individual character select lines. To display a particular digit, letter, or symbol at a particular position on the 32-character display, the segment lines corresponding to the desired digit, letter or symbol are enabled and the desired display character selected. The individual characters of the display are sequentially selected by the outputs of a 32-bit shift register, referred to as the character shift register. The character shift register is driven by the peripheral microcomputer, which writes first to both the data input and clock input, and then 31 times to the clock input only, all via its output port. The 32 writes to the character shift register cause one bit to shift completely through the register, sequentially selecting each character position of the display.

3-62. Between each of the 32 writes to the character shift register, the peripheral microcomputer writes the segment and decimal point data (to the segment shift register) which is to be displayed at the next character position of the display. Once the segment shift register is loaded, the

peripheral microcomputer writes an Output Enable signal to gate the segment data to the display segments.

3-63. The peripheral microcomputer refreshes the display at a 61.5 Hz rate while also controlling the annunciators (MORE, LOOPING, STOPPED, PROGMIN, and EXECUTING) and polling the keyboard for operator commands. The peripheral microcomputer selectively turns each of the five annunciators on by writing a low to the corresponding input of annunciator latches, U15. The control section microprocessor provides the data which determines the particular latches written to, while the peripheral microcomputer U1 controls the flashing of the annunciators by writing and clocking high and low inputs to the latches.

3-64. The peripheral microcomputer receives keyboard commands by routinely polling its input port. The input port is connected to the columns of the 8-by-8 keyboard matrix. The rows of the keyboard matrix are connected to the outputs of the row shift register, U2. The row shift register is clocked by the same peripheral microcomputer output used to clock the character shift register. The row shift register receives a single bit of data at its input each time the character shift register selects character position 9 of the display. The result of this activity is that the keyboard rows are sequentially enabled once each time the character shift register cycles through the 32 display character position.

3-65. Whenever a particular row is enabled and a keyboard key is pressed, the column corresponding to that key produces an input to the input port of the peripheral microcomputer. Since the peripheral microcomputer controls which row is enabled and receives the column information directly from the keyboard, it determines the key pressed and places a corresponding byte of keyboard data on the data bus. The control section microprocessor routinely polls the peripheral microcomputer for keyboard data and, from such data, determines the key pressed at the keyboard.

3-66. The display assembly also contains a filament drive circuit consisting of a set-reset flip-flop and drive transistors. The filament drive circuit alternates the polarity of the display V1 filament each time display characters 1 and 17 are selected by the character shift register. As a result, the polarity of the filament alternates twice per display refresh, to provide an average of six volts to the filament with no gradient across the tube. This is necessary to prevent a varying light output intensity over the length of the tube.

NOTE

Refer to Table 4-13 for a list of display assembly protocol (address and command data).

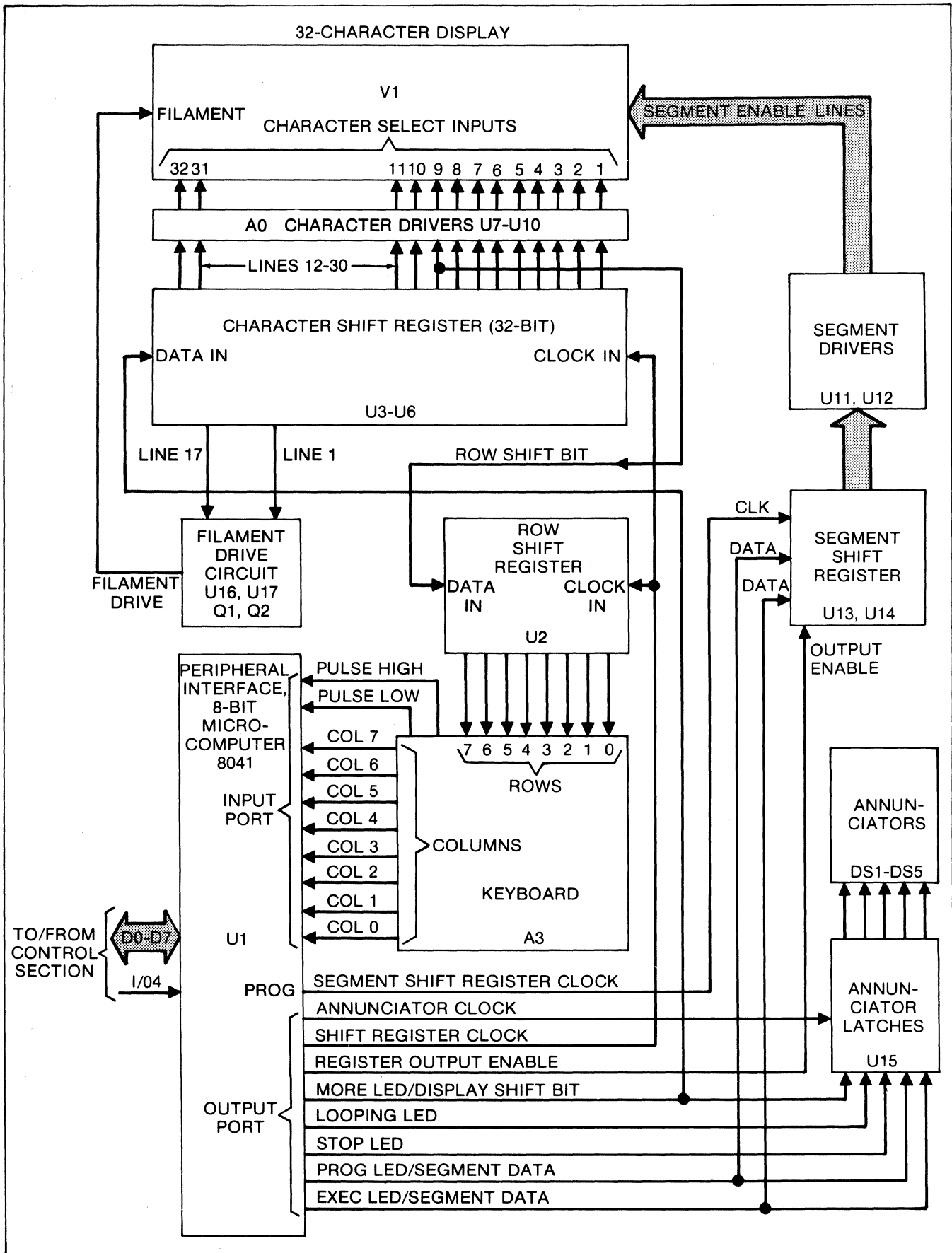

Figure 3-5. Display/Keyboard Assemblies

3-67. Pod/Probe PIA

3-68. The pod/probe PIA (peripheral interface adapter) provides interface of the probe logic to the control section, and also of the interface pod to the control section. As shown in Figure 3-6, the PIA connects to the control section by means of the data bus and part of the address bus. The PIA also receives control signals from the \overline{RD} line of the microprocessor, the \overline{IOREQ} line of the microprocessor, and the I/O selector (via flip-flop U34).

3-69. The two I/O ports of the PIA are connected to the probe logic and to the interface pod. Each port is bidirectional and separately addressable by means of address lines A0 and A1. To command the probe logic, the microprocessor first addresses and writes to the I/O port A control register. (This is necessary in order to address either the I/O port A data direction register or I/O port A data buffer within the 6520 PIA, since both have the same address.) The microprocessor then writes to the I/O port A data direction register to set lines PA5, PA6, and PA7 as outputs. The microprocessor again addresses the I/O port A control register (this time to permit addressing of the I/O port A data buffer), followed by a write to the I/O port A data buffer to place data on lines PA5, PA6, and PA7 as required to control the probe logic. Refer to Table 4-13 for addresses and write data which perform pod/probe PIA functions.

3-70. To receive data from the probe logic, the microprocessor addresses and writes to the I/O port A control register (to permit addressing the I/O port A data direction register). A subsequent write to the I/O port A data direction register sets lines PA5, PA6, and PA7 as inputs. The microprocessor again addresses the I/O port A control register (to permit addressing the I/O port A data buffer) followed by a read to the I/O port A data buffer to receive the data placed on lines PA5, PA6, and PA7 by the probe logic.

NOTE

The function of the PA5, PA6, and PA7 lines is described in the subsequent probe logic description.

3-71. Pod Communication

3-72. The control section communicates with the interface pod by sending commands, and receiving data in response to the commands. The transmission of commands and reception of data is mediated by two handshake lines labeled $\overline{MAINSTAT}$ and $\overline{PODSTAT}$.

3-73. To command the interface pod, the microprocessor first addresses and writes to the I/O port A control and data direction registers to set line PA0 ($\overline{MAINSTAT}$) as an output. The microprocessor then addresses and writes to the I/O port A control register and data buffer to set line PA0 low and create the $\overline{MAINSTAT}$ signal. The interface pod responds to the

$\overline{MAINSTAT}$ signal by developing the $\overline{PODSTAT}$ output signal. The microprocessor, after writing the $\overline{MAINSTAT}$ signal, again writes to the I/O port A control and data direction registers to set the PA1 line as an input. With the PA1 line set as an input, the microprocessor writes to the I/O port A control register and then reads at the port A data buffer. When the $\overline{PODSTAT}$ signal appears (PA1 goes low), the microprocessor proceeds to write data to the interface pod using the control register, data direction register, and the data buffer of I/O port B. Refer to Figure 3-7 for $\overline{MAINSTAT}$ and $\overline{PODSTAT}$ signal details, and to Table 4-13 for a list of pod/probe PIA addresses and commands.

3-74. During PIA operation, the PIA R/\overline{W} line controls data direction from the microprocessor, the data bus provides or receives the data, and lines A0 and A1 select control register or data direction register/data buffer of I/O ports A and B. The previously described control section provides clock pulses via U32, and the PIA is chip selected by the I/O selector, with some delay provided by flip-flop U34.

3-75. Probe Logic

3-76. The probe logic, shown in the block diagram Figure 3-8, provides the following functions:

- Receiving and interpreting logic pulses from the probe tip and reporting their condition to the microprocessor.
- Lighting the probe lamps in accordance with the logic signals appearing at the probe tip.
- Providing probe tip signals to the signature generator and event counter circuit.
- Providing high and/or low logic signals to the probe tip as directed by the microprocessor.
- Generating a differentiated pod Sync pulse for application to an oscilloscope as an external trigger signal.

3-77. RECEIVING PROBE TIP SIGNALS

3-78. High, low, and invalid signals applied to the probe tip are fed to an input of the probe logic as indicated in Figure 3-8. A network made up of R25, R26, C51 and C52 provides probe compensation, while Q1 provides high input and low output impedances. A pair of level detectors, one to detect logic high levels (U36/U41), and one to detect logic low levels (U49/U41), receive the incoming signals from the probe tip. The high level detector produces a output for the duration of logic high signals ($>+2.4$ volts), while the low level detector produces a output for the duration of logic low signals ($<+0.8$ volts). During signals of invalid levels ($+0.8$ to 2.4 volts), neither level detector produces an output.

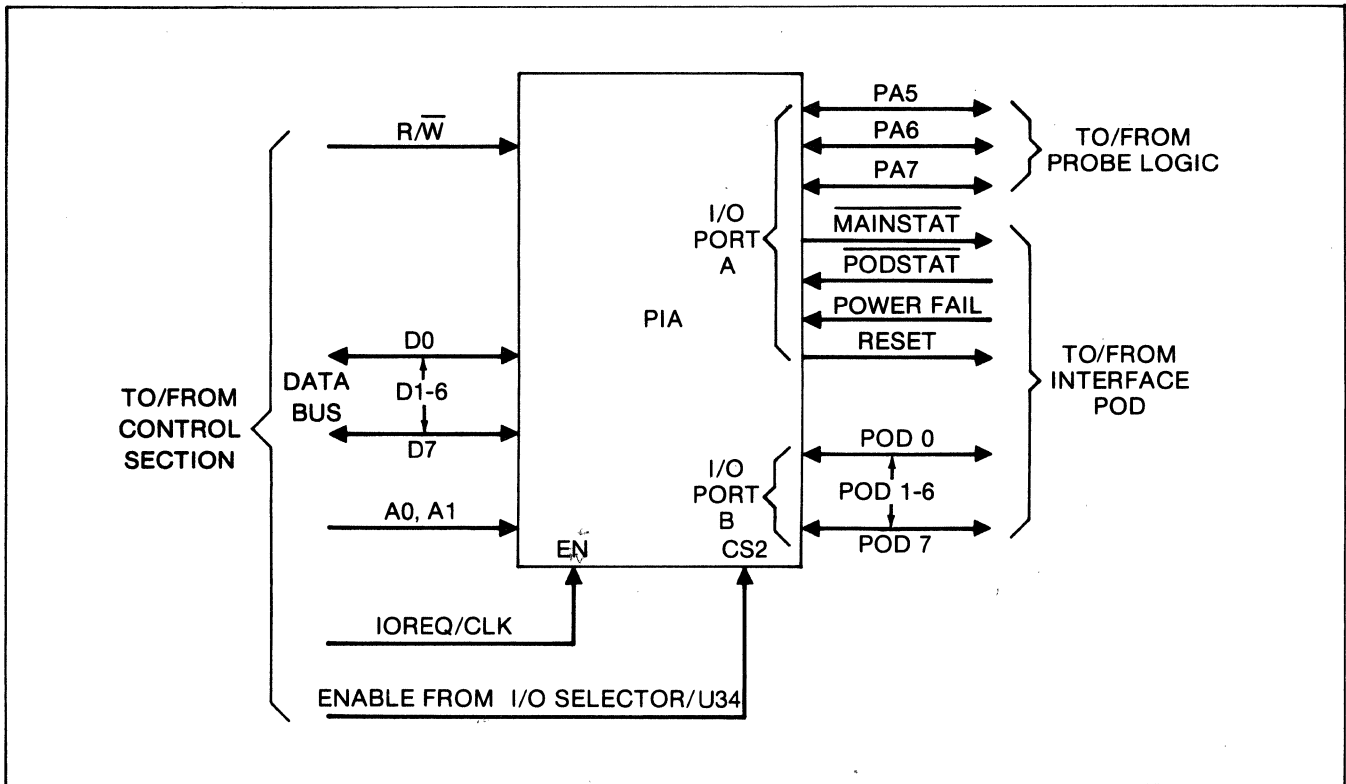

Figure 3-6. Pod/Probe PIA Signals

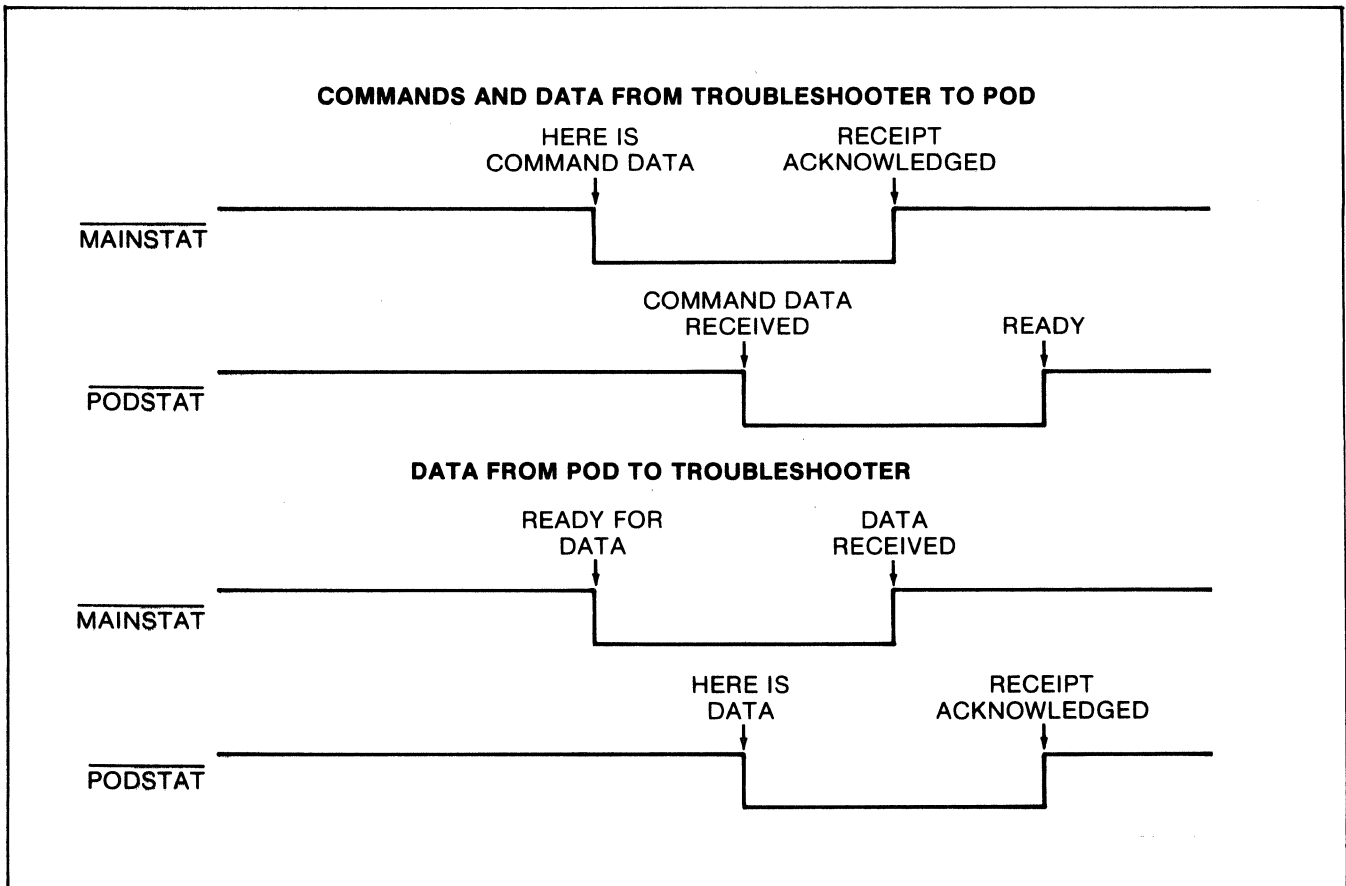

Figure 3-7. MAINSTAT/PODSTAT Signals

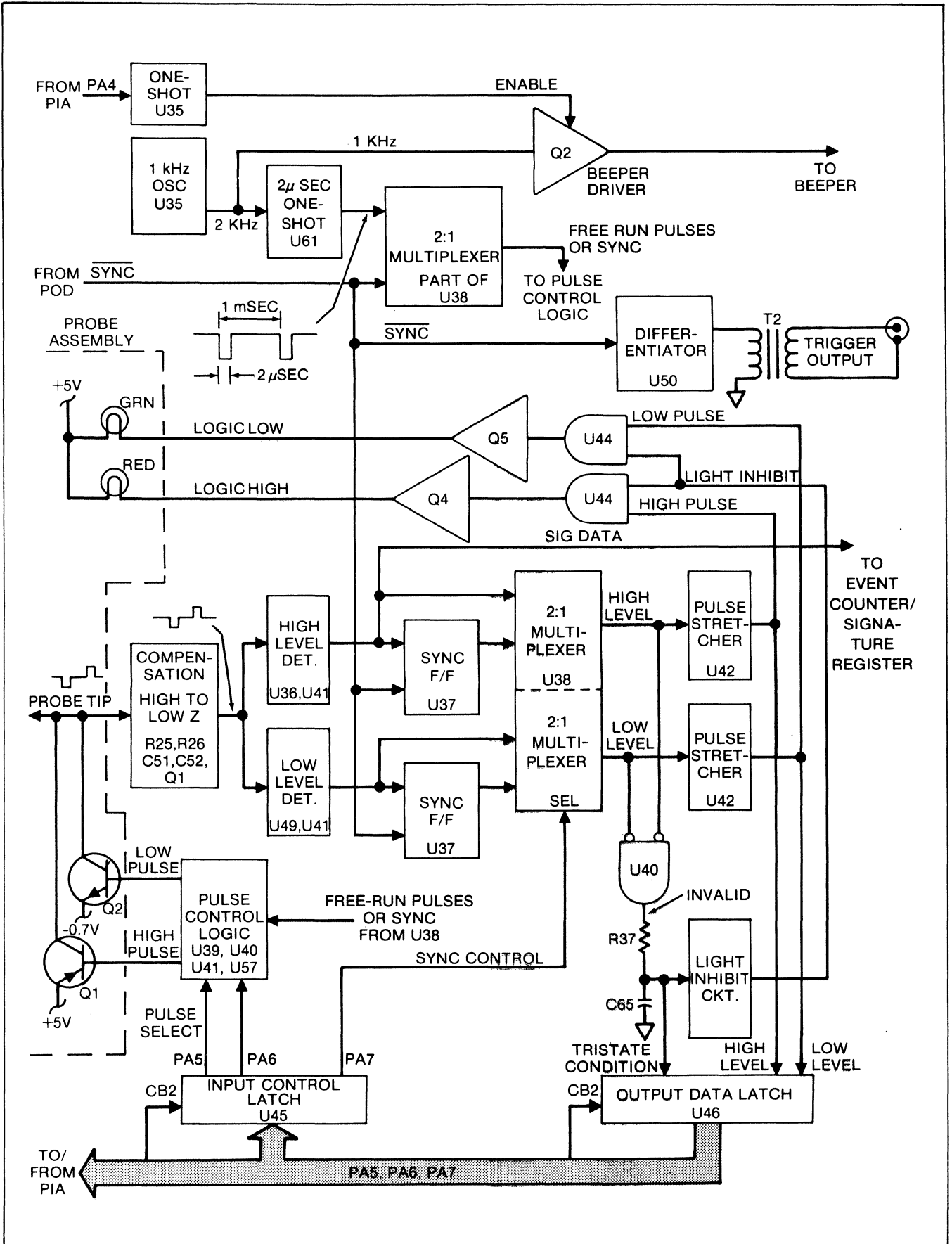

Figure 3-8. Probe Logic

3-79. SYNCHRONIZED/FREE-RUNNING OPERATION

3-80. The sync select flip-flops, U37, and 2:1 multiplexer, U38, permit selection of synchronized or free-running probe operation. Synchronized operation allows the troubleshooter to detect only probe levels which exist at the time the interface pod terminates the SYNC signal (refer to the interface pod manual for Sync signal details). Free-running operation allows the troubleshooter to detect probe levels asynchronously with respect to pod operations.

3-81. Signals from the high and low level detectors are fed both through and around the sync select flip-flops to two sets of multiplexer, U38, inputs. The signals from the high level detector are also fed as SIG Data (signature data) over to the signature generator data input and event counter clock input. One set of multiplexer inputs receives the levels latched into the sync flip-flops at the termination of the interface pod $\overline{\text{SYNC}}$ signal. This set of multiplexer inputs is used during operation in the synchronized mode of probe operation.

3-82. The other set of multiplexer inputs receives signals produced by the high and low level detectors, and corresponds to the free-running mode of probe operation. Selection of either multiplexer input for connection to its output is made by the Sync Control signal fed from the input control latch, U45. The input control latch receives a synchronize or free-running command from the microprocessor via the pod/probe PIA and line PA7.

3-83. PROBE LAMP CONTROL

3-84. The probe contains two lights, one green and one red, which are driven by Q5 and Q4 in conjunction with U44 and pulse stretchers (one-shots), U42. The pulse stretchers have a 200 millisecond duration and provide a means of making probe pulses of short duration visible on the probe indicator lights. Probe pulses of longer than 200 millisecond duration are fed around the one-shots and override their outputs. This arrangement allows pulses of short duration to be visible on the indicator lights for 200 milliseconds, and also allows pulses longer than 200 milliseconds to be visible for their entire duration. When the probe receives a logic high level, the red light glows, and when the probe receives a logic low level, the green light glows.

3-85. Signals, which are neither valid logic high nor valid logic low, cause the probe lights to go off. When an invalid level appears at the probe, neither the high level detector U36/U41 nor the low level detector U49/U41 provide an output. As a result, the outputs of the 2:1 multiplexer are both low. Gate U40 detects the lack of multiplexer outputs and produces a high output to the light inhibit circuit, U39/U43, via the integrator formed

by R37 and C65. The integrator prevents the light inhibit circuit from responding to invalid signals having a duration of approximately 100 nanoseconds or less. Since a normal TTL edge can spend up to about 10 nanoseconds in the invalid region, the transistions will not cause the lights to flash.

3-86. The light inhibit circuit consists of two one-shots, each triggered at the occurrence of an invalid signal, the first having a duration equal to one-half (100 milliseconds) that of the second (200 milliseconds). The output of the second one-shot inhibits the input to the first so that an invalid signal triggers the first one-shot only as long as the second one-shot has returned to its stable state. As long as an invalid signal is present at the integrator, the first one-shot continues to be triggered, producing a 100 millisecond pulse every 200 milliseconds. The output of the first one-shot is the output of the light inhibit circuit.

3-87. The output of the light inhibit circuit enables gates U44 when invalid signals are less than about 100 nanoseconds in duration, but inhibits them for 100 milliseconds when invalid for longer than approximately 100 nanoseconds. Since U44 directs the outputs of the pulse stretchers to line drivers Q4 and Q5, the lights are turned off whenever the light inhibit circuit produces an output pulse, causing one or both lights to flash at a 5 Hz rate.

3-88. During a steady invalid signal, the light inhibit signal produces 100 millisecond pulses at the 5 Hz rate, but the lights stay off due to the lack of outputs at the pulse stretchers.

3-89. PROBE FUSE SENSING

3-90. The ground path for the probe contains a fuse, F2. A sensing circuit, shown in Figure 3-9, detects failure of the fuse and/or connection of the probe ground lead to any positive or negative supply. Normally, the probe ground lead ties to ground via fuse F2. However, when an overload condition causes failure of F2, the ground lead goes to +5 volts due to a pull-up resistor (R4) contained in the probe. The +5 volts turns Q3 on to produce the $\overline{\text{FB}}$ (fuse blown) signal fed to the event buffer shown in Figure 3-10. The microprocessor reads the contents of the event buffer during the read probe operation, and examines the $\overline{\text{FB}}$ (fuse blown) bit for a blown fuse condition. If the $\overline{\text{FB}}$ line is low, the blown probe fuse messages appears on the troubleshooter display.

3-91. If the probe ground lead is connected to a negative supply, the fuse blows, but Q3 remains off due to the negative voltage at its base. In this case, Q6 turns on to produce the low $\overline{\text{FB}}$ signal and notify the microprocessor of the blown fuse condition.

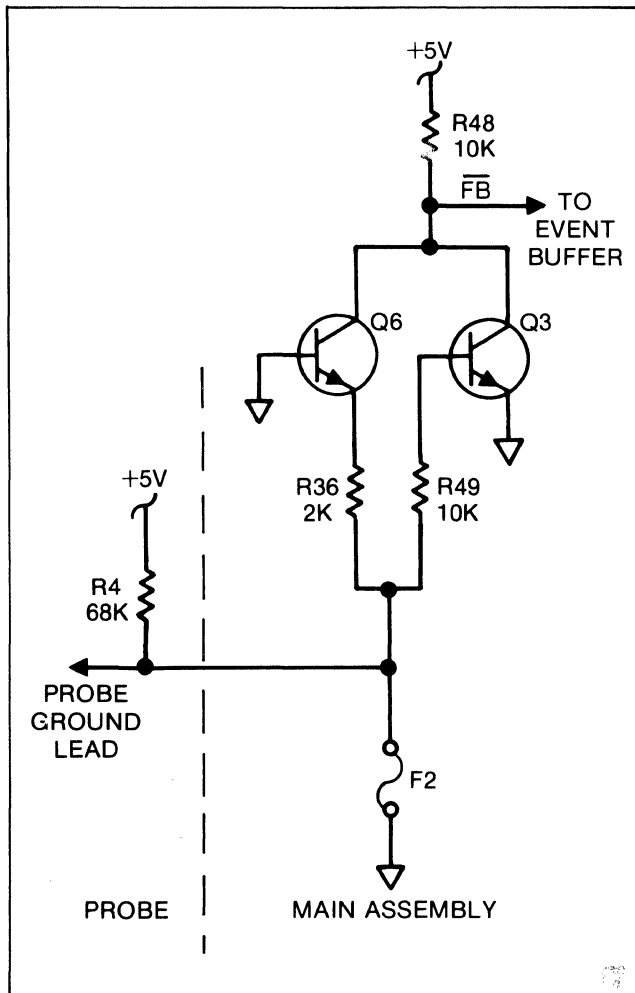

Figure 3-9. Probe Fuse Sensing Circuit

3-92. PROBE STATUS REPORTING

3-93. The probe logic reports the result of probe operations to the microprocessor by indicating the occurrence of logic high, logic low, and invalid signals. The occurrence of a logic high and/or logic low signal causes an output at one or both of the pulse stretchers. The pulse stretcher outputs are connected to respective inputs of the output data latch, U46. The occurrence of a 100 nanosecond or greater invalid signal causes an input to the light inhibit circuit, and also to an input of the output data latch. The output data latch stores its inputs and, when enabled by the CB2 signal from the pod/probe PIA, places the stored high, low, and/or invalid signal condition on PIA lines PA5, PA6, and PA7. The pod/probe PIA operates under microprocessor control to place the probe signal condition data on the microprocessor data bus.

NOTE

The invalid state goes unreported when operating in the synchronized mode. This is due to the controlling software and not the hardware.

3-94. PROBE PULSE GENERATION/CONTROL

3-95. The probe logic generates pulses, either synchronized to the interface pod or free-running at 1 kHz, high or low, for application via the probe to a UUT. Synchronized probe pulses are derived from the Sync signal (generated by the interface pod at valid address/data times), while free-running pulses are derived from a 1 kHz-oscillator/2-microsecond one-shot combination. Each probe pulse source connects to an input of a third section of the 2:1 multiplexer, U38 (described previously under Synchronized/Free-Running Operation). The Sync Control signal fed from input control latch, U45, makes selection of either multiplexer input for connection to the output. The input control latch receives a synchronize or free-running command from the microprocessor via the pod/probe PIA and line PA7.

3-96. For synchronized pulses, the multiplexer selects the SYNC signal for application to the pulse control logic (U39, U40, U41, U57). For free-running pulses, the multiplexer selects the 1 kHz-oscillator/one-shot output for application to the pulse control logic. The 1 kHz oscillator output triggers a 2 microsecond one-shot to produce a continuous stream of 2 microsecond pulses at a 1 KHz rate.

3-97. The pulse control logic accepts either SYNC pulses from the interface pod or 2 microsecond pulses from the 1 kHz-oscillator/one-shot, and accepts pulse select signals from input control latch, U45. Pulse select signals provided by U45 originate with the microprocessor and are written to the pod/probe PIA, and then to the input control latch via PIA lines PA5 and PA6.

3-98. Flip-flop U57, of the pulse control logic, in conjunction with the PA5 and PA6 signals from the PIA, allow the probe to pulse high, pulse low, or alternate between high and low by means of transistor switches Q1 and Q2, contained in the probe. The width of the output pulse is 2 microseconds for free-running mode, and equal to the pod SYNC pulse in the synchronized mode.

3-99. SCOPE TRIGGER OUTPUT

3-100. The probe logic includes a differentiator/amplifier circuit, U50, which provides negative-going and positive-going pulses at a rear panel-mounted BNC connector. These pulses, intended for application to the trigger input of an oscilloscope, result from the negative-going and positive-going edges of the interface pod SYNC signal, and as a result, are coincident with the SYNC signal. A pulse transformer provides output coupling to the rear panel connector and isolates the scope ground (tied to earth ground) from the system ground.

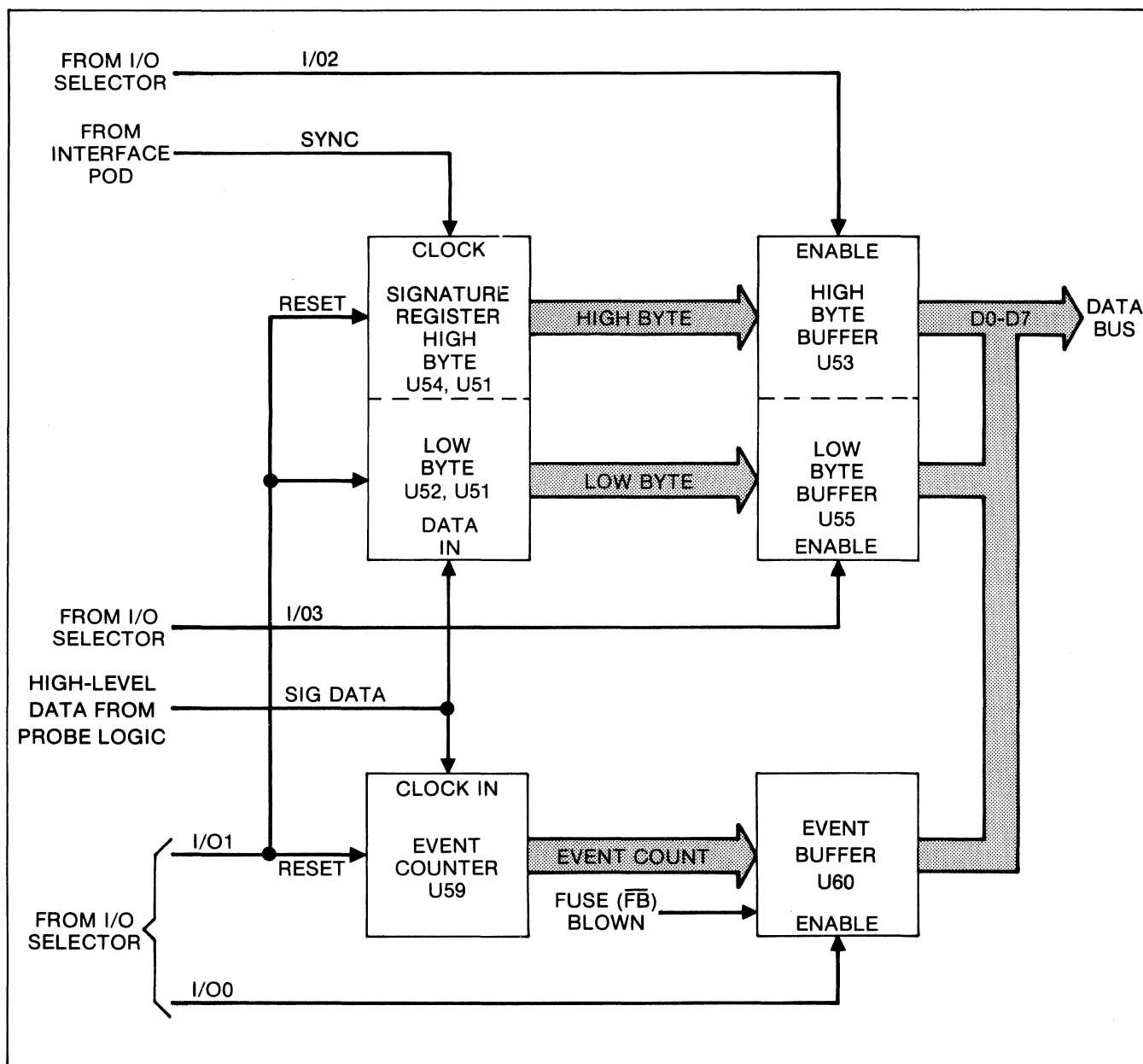

Figure 3-10. Signature Register/Event Counter

3-101. Signature Generator and Event Counter

3-102. The signature generator consists of a pair of clocked shift registers (U52 and U54) equipped with exclusive-OR (U51) feedback to produce a unique four-digit (16-bit) hexadecimal signature. The signature generator utilizes the high-level data provided by the probe logic for data input, and the SYNC signal provided by the interface pod for the signature clock input. The traditional start and stop signature times are controlled from the execution of a read probe function within a 9010A user program.

3-103. As shown in Figure 3-10, the SIG Data signals provided by the high level detector of the probe logic are fed to the data input of the signature register. The Sync

signal from the interface pod is applied to the clock input. As a result, any logic state appearing at the probe tip at the time of the SYNC signal (trailing edge) affects the state of the signature register. The timing of the SYNC and probe signals, in conjunction with the exclusive-OR feedback allows the signature register to produce unique signatures at different UUT test points. Since the signature register is clocked only by each interface pod-produced UUT event, the probe signature is always synchronized to interface pod/UUT activities regardless of the sync selected by the front panel SYNC key.

3-104. The high byte and low byte buffers (U53 and U55) receive the signature from the register and gate it, one byte at a time, onto the data bus as commanded by the microprocessor. The I/O2 signal from the I/O selector

gates the high byte of signature data onto the data bus; the $\overline{I/O3}$ signal gates the low byte.

3-105. The event counter U59 produces a seven-bit count (0-127 with wrap-around) of logic high-to-invalid transitions appearing at the probe tip. The input to the event counter is provided by the SIG Data signal from the high level detector of the probe logic. The event buffer, U60, gates the seven-bit event count plus the one-bit fuse-blown (\overline{FB}) indication onto the data bus in response to the $\overline{I/O0}$ signal from the I/O selector as commanded by the microprocessor.

3-106. The microprocessor resets both the signature generator and the event counter by means of the $\overline{I/O1}$ output of the I/O selector. Reset occurs at the beginning of all read probe operations.

3-107. Magnetic Tape Controller

3-108. INTRODUCTION

3-109. The Magnetic Tape Controller provides control of the magnetic tape unit in response to commands from the microprocessor. The Magnetic Tape Controller contains a peripheral microcomputer which, under internal software control, performs the following functions:

- Reads to or writes from the tape.
- Controls tape direction and speed.
- Rewinds tape.
- Positions tape at load point.
- Formats write words.
- Decodes read words.
- Detects end of tape.
- Detects cassette present/not present.
- Detects write-protected cassette.
- Detect synchronization errors.
- Reports tape subsystem status to the microprocessor.

NOTE

Refer to Table 4-13 for a list of addressing protocol for the magnetic tape controller.

3-110. Selection (addressing) of the Magnetic Tape Controller by the microprocessor is done by means of the $\overline{I/O5}$ output of the I/O selector described earlier in this

section. In addition, address line A0 provides the controller with two addresses. When the microprocessor writes A0 low, the information placed on the data bus is for a read data or write data operation, as determined by the \overline{RD} or \overline{WR} lines. However, when A0 is written high, a write operation issues a command to the peripheral microcomputer to place controller status on the data bus. The peripheral microcomputer also receives the system \overline{RES} signal generated by the power-on reset and watchdog timer circuits. Refer to Figure 3-11 for a block diagram of the magnetic tape controller.

3-111. TAPE DRIVE MOTOR CONTROL

3-112. A speed-regulated reel-drive motor moves the magnetic tape over the read/write head. To operate the motor in the forward direction, the peripheral microcomputer writes an output to the Forward line (and also an output to the \overline{E} line to enable all controller functions). The Forward signal operates the switch formed by U4B to connect the positive side of the tape drive motor to the +5 volt supply. As a result, motor current flows through U4B, through the motor, and out through back-EMF regulator, U6. The back-EMF regulator senses the voltage across the motor, which is proportional to motor speed, and provides the feedback necessary to maintain a constant motor speed. Potentiometer R14 provides a means of setting motor speed.

3-113. To operate the motor in the rewind direction, the peripheral microcomputer writes an output to the REWD line, and also to the \overline{E} line. The REWD signal turns on solenoid driver, U4A, to actuate the rewind solenoid, closes the switch formed by U4C, and closes the switch formed by U4D and Q1. As a result, motor current flows from the +5 volt supply through U4C, bypasses U6, flows through the motor and through Q1 to the ground. Since regulator U6 is bypassed, motor rewind speed is uncontrolled and is the maximum provided by five volts.

3-114. WRITE CONTROL

3-115. To avoid any possible errors which might result from tape jitter or speed variation, a method of ratio encoding is used to write all data on the tape. Figure 3-12 illustrates the method of ratio encoding employed by the magnetic tape controller. Any data bit is either 2/3 bit time high or low, with the other 1/3 bit time of the opposite polarity. A one bit begins low, and after 1/3 of the bit time makes a transition to high for the remaining 2/3 of the bit time. A zero bit also begins low, but stays low for 2/3 of the bit time, after which it makes a transition to high for the remaining 1/3 of the bit time. Under this coding scheme, the first 1/3 of a bit is always low, and the last 1/3 of a bit is always high. An extra 1/3 low provides a stop mark, and an inter-word high of 1-2/3 bit times is written for synchronization purposes. A high for ten word lengths indicates end-of-file.

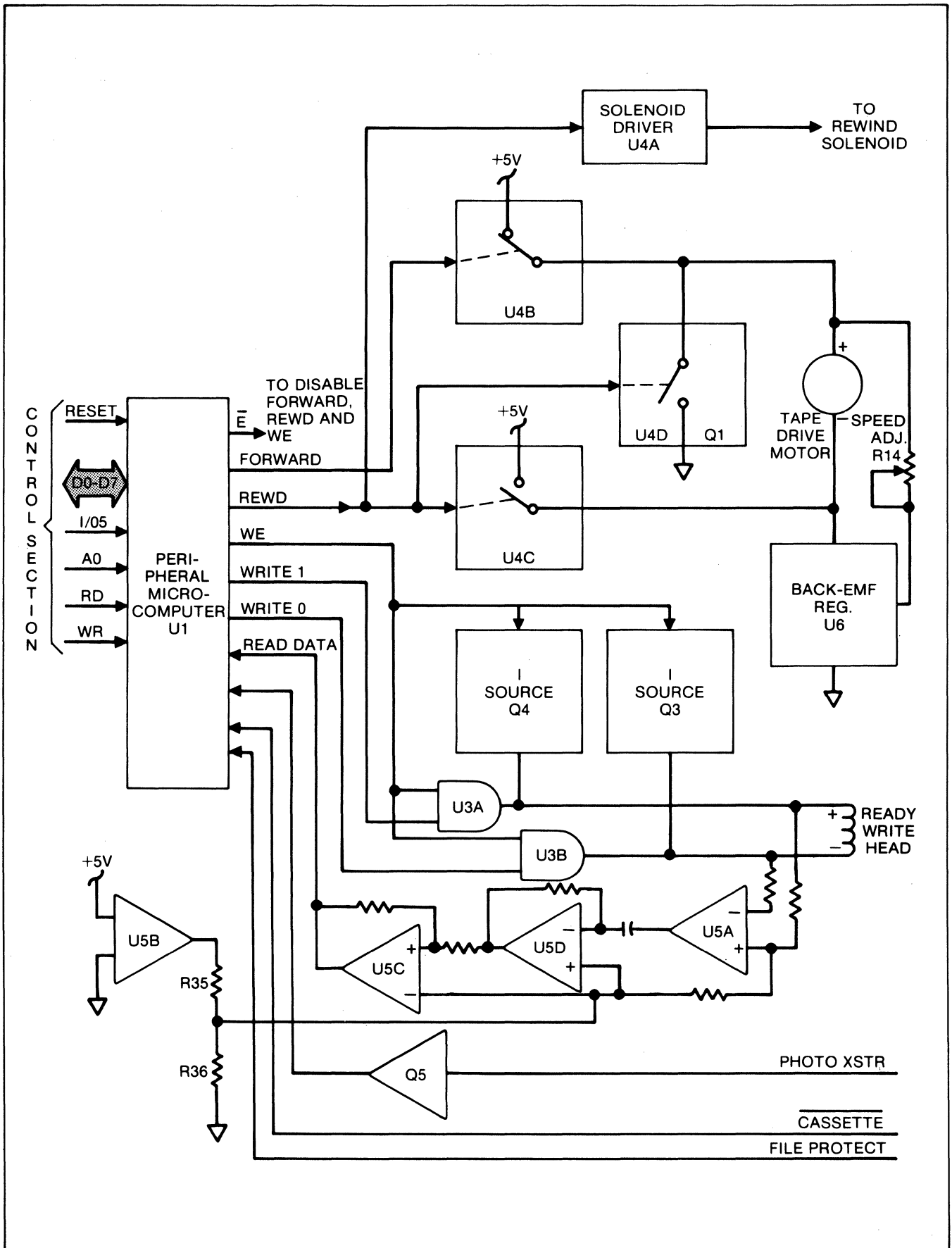

Figure 3-11. Magnetic Tape Controller

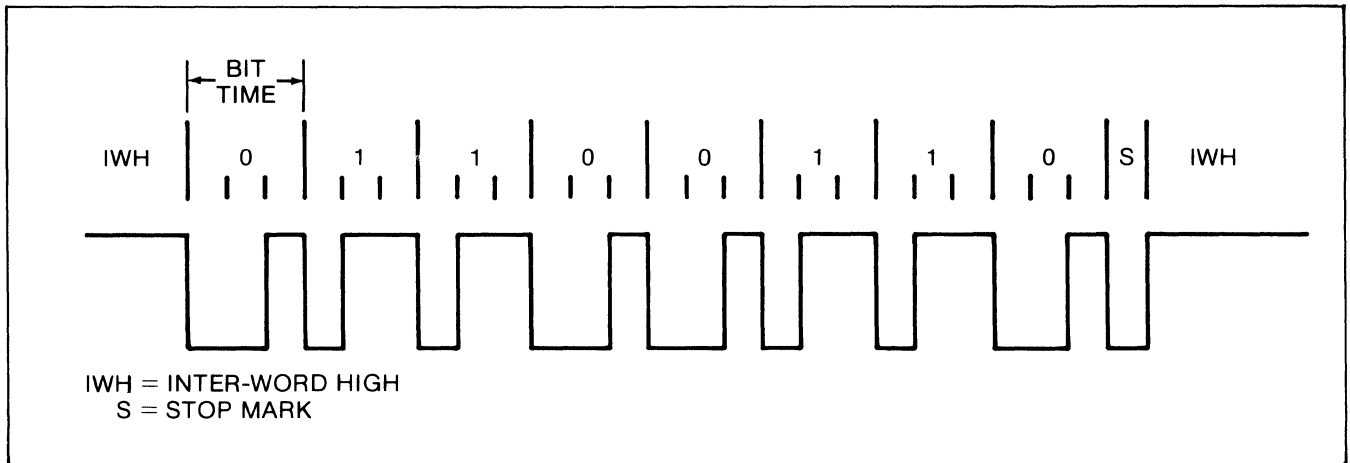

Figure 3-12. Tape Data Ratio Coding

3-116. To write to the tape, the peripheral microcomputer writes a WE (write enable) signal to current sources Q3 and Q4, and to current sinks U3A and U3B. The WE signal turns on the current sources and enables the current sinks. To write a high to the tape, the peripheral microcomputer writes to the WRITE 1 line to turn on current sink, U3A. When turned on, U3A directly sinks the current supplied by Q4, and also sinks the current supplied Q3 after passing through the read/write head in a negative-to-positive direction.

3-117. The read/write head records the transition as a flux change on the tape. To write a low to the tape, the peripheral microcomputer writes to the WRITE 0 line to turn on current sink, U3B. When turned on, U3B directly sinks the current supplied by Q3, and also sinks the current supplied by Q4 after passing through the read/write head in a positive-to-negative direction (opposite to the direction when writing a high level). The read/write head records the transition as a flux change on the tape, but of the opposite polarity of that recorded for the high portion of a data bit.

3-118. PLAYBACK AMPLIFIER

3-119. All signals appearing across the read/write head, including those written by the peripheral microcomputer, are applied to the input of the playback amplifier made up of U5A, U5B, U5C, and U5D (shown in Figure 3-11). The purpose of U5B is to establish a reference voltage which is halfway between the upper and lower output limits of the other three stages. Since the output characteristics of U5B are similar to the other three stages, and R35 and R36 are

equal, applying +5 volts across the input of U5B produces a level equal to half its saturated output across R36.

3-120. Section U5A of the amplifier provides a gain of 200 and forms the first stage of the playback amplifier. The output of U5A is applied to differentiator stage U5D. CR8 and CR9 are provided to prevent this stage from going into saturation. The final stage is a center-crossing detector with a 25% (approx. $\pm 0.4V$) hysteresis. The three stages combined are used to detect the points of flux reversal on the tape. The output of the playback amplifier connects via the Read Data line to an input of the peripheral microcomputer. The peripheral microcomputer continuously reads this input during a read operation and decodes the incoming data into logic highs and logic lows.

3-121. OTHER FUNCTIONS

3-122. The Magnetic Tape Controller includes three other functions required for proper tape handling, each of which is reported to the peripheral microcomputer. An LED and phototransistor mounted on the tape path provide an indication of end-of-tape when the clear section of tape allows the passage of LED output to reach the phototransistor. Transistor Q5 amplifies the phototransistor output for application to the peripheral microcomputer. In addition, a low Cassette signal indicates the presence of a cassette in the tape drive to the peripheral microcomputer; and a high File Protect signal indicates a write protected (the tab broken out) cassette. Both the File Protect and Cassette signals are produced by microswitches.

Section 4 Maintenance

4-1. INTRODUCTION

4-2. This section of the manual contains routine maintenance and troubleshooting information for the 9010A. A list of recommended test equipment is given in Section 1, Table 1-1.

4-3. GENERAL INFORMATION

NOTE

The 9010A is double-insulated from the power line. Although the rear panel is connected to earth (green wire), internal signal ground or logic common is floating. Consequently, ground connections for external test equipment must be made to logic common (TP2) on the main assembly.

4-4. Access Information

4-5. To gain access to the all PCB assemblies of the troubleshooter, proceed as follows:

1. Invert the instrument on a clean surface and remove the seven retaining screws from the bottom side.
2. Carefully return the instrument to the upright position while holding the top cover in place. Once in the upright position, remove the top cover and lay it to the right side of the instrument.
3. The top cover assembly includes the tape deck and display/keyboard. The display/keyboard is held to the top cover by 2 clips, which must be removed if this assembly needs service.

4-6. Cleaning

CAUTION

Do not use aromatic hydrocarbons or chlorinated solvents for cleaning. These solutions will react with the plastic materials used in the instrument.

4-7. Clean the front panel, the display lens, and the case with a mild solution of detergent and water. Clean dust from the circuit board with low pressure (<20 psi) dry air. Contaminates can be removed from the circuit boards with demineralized water and a soft brush. Dry with clean dry air at low pressure, and then bake at 50 to 60 degrees C (124-140 degrees F) for 24 hours.

4-8. Cleaning of the magnetic tape drive is limited to occasional cleaning of the read/write head. The need for head cleaning is evidenced by the presence of iron oxide. Clean the head with cotton swabs moistened with isopropyl alcohol. Continue to clean the head until the swabs cease to be discolored.

4-9. FUSE REPLACEMENT

4-10. Line Fuse

4-11. The line fuse (F1) is located in a recessed compartment in the rear panel. Figure 4-1 illustrates line fuse replacement. To replace the fuse, proceed as follows:

1. Remove the power cord from the instrument.
2. Slide the clear plastic panel up to expose the fuse compartment.
3. Pull up the plastic lever (as shown in Figure 4-1) to slide the fuse out of the compartment.
4. Replace the fuse with a 1 ampere fast-blow, 250V (part no. 369819) for 100 and 120 volt operation; and with a 1/2 ampere fast-blow, 250V (part no. 153858) for 220 and 240 operation.

4-12. Probe Fuse

4-13. The troubleshooter detects a probe fuse failure by halting operation and displaying the message REPLACE PROBE FUSE/UNPLUG PROBE. (Typically, the probe fuse is blown by inadvertently connecting the probe ground clip to a power source.) To replace the probe fuse, proceed as follows:

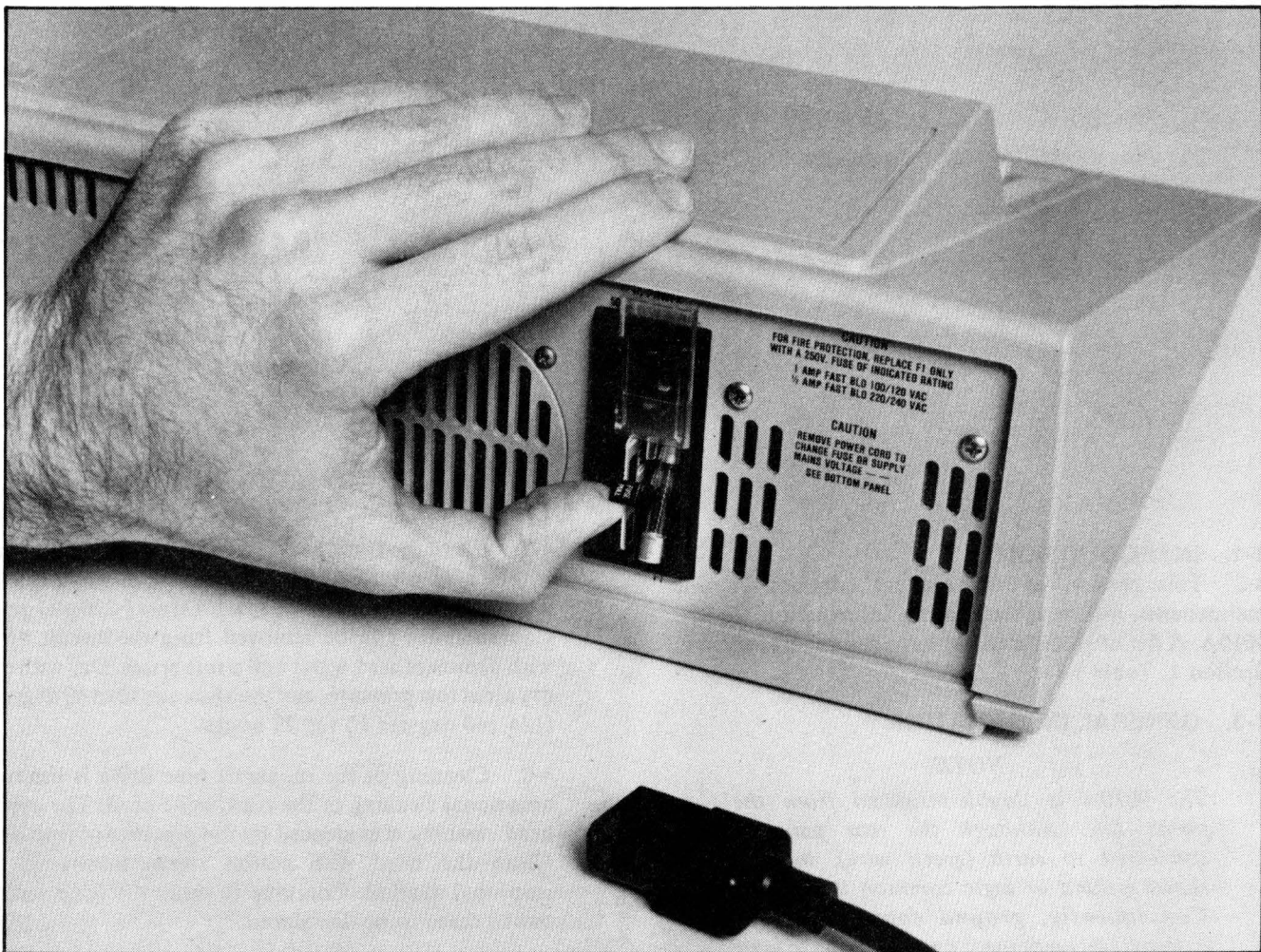

Figure 4-1. Line Fuse Replacement

1. Tilt up the front of the instrument and locate the probe fuse cap shown in Figure 4-2.
2. Remove the fuse cap by turning 1/8 turn counterclockwise with a screwdriver. Pull out the fuse with the fuse cap. Note the color of the fuse cap.
3. Replace the fuse with one having a 1/4 ampere, 250V rating. For black fuse caps use Fluke part number 543504 (5x20 mm), for grey fuse caps use Fluke part number 109314 (3AG).

NOTE

If a spare fuse is not immediately available, remove the probe from the troubleshooter to continue operation without the probe.

4-14. PERFORMANCE TEST

4-15. Self Test

4-16. Upon application of power, the troubleshooter performs a self test to verify proper operation of internal

ROM and RAM. Upon successful completion of self test, the troubleshooter displays the message FLUKE 9000 POWER-UP OK VER-*nn*, where *nn* represents a number corresponding to the software version contained in the instrument.

4-17. If the self test routine detects a ROM or RAM problem, the troubleshooter displays the message FLUKE 9000 POWER-UP FAIL *mm*, where *mm* equals a two-digit hexadecimal failure code. Table 4-1 lists the failure codes and their meanings.

4-18. Troubleshooter self test may also occur at times other than power-on; referred to as restart. The troubleshooter contains a watchdog timer circuit which initiates self test whenever internal operation does not appear normal. In this case, the troubleshooter displays the message FLUKE 9000 RESTARTED SELF TEST followed by either FLUKE 9000 RESTARTED OK VER-*nn* (where *nn* equals the software version) or FLUKE 9000 RESTARTED FAIL *mm* (where *mm* equals a failure code listed in Table 4-1).

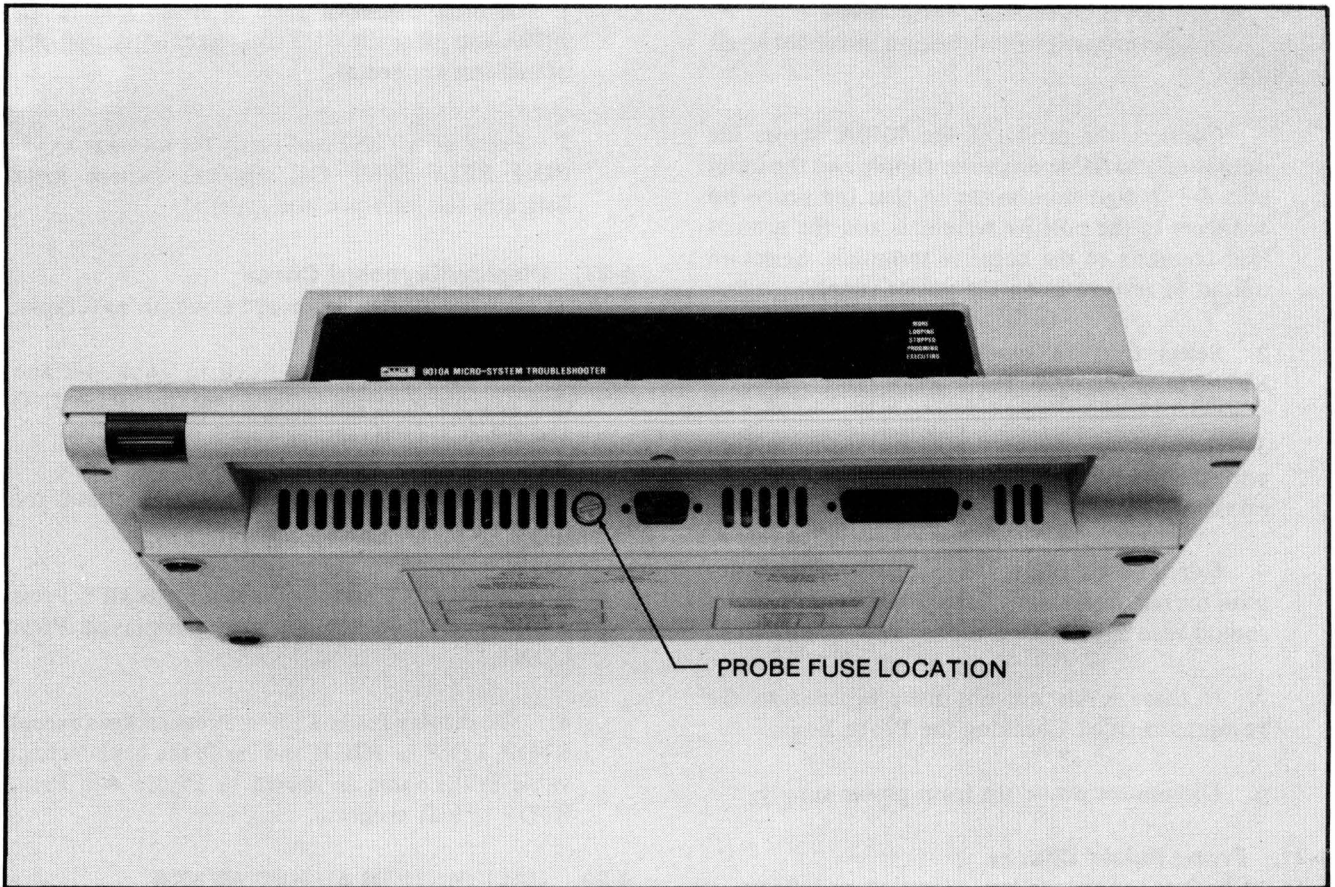

Figure 4-2. Probe Fuse Location

Table 4-1. Self Test Failure Codes

CODE	INDICATED FAILURE
02	RAM failed write FF during power-on
03	RAM failed write FF during restart
04	RAM failed write 00 during power-on
05	RAM failed write 00 during restart
06	RAM failed write FF/00 during power-on
07	RAM failed write FF/00 during restart
08	ROM check failed during power-on
09	ROM check failed during restart
0A	RAM failed write FF and ROM check during power-on
0B	RAM failed write FF and ROM check during restart
0C	RAM failed write 00 and ROM check during power-on
0D	RAM failed write 00 and ROM check during restart
0E	RAM failed write FF/00 and ROM check during power-on
0F	RAM failed write FF/00 and ROM check during restart

4-19. Probe Level Detection/Verification

4-20. Check for proper probe detection threshold levels as follows:

1. Connect the probe of the 9010A across the output of a variable dc power supply and the input of a 3-1/2 digit multimeter so that the probe tip connects to the positive terminals and the ground lead connects to the negative terminals. Select an output of zero volts on the power supply.
2. Select free-run synchronization by pressing SYNC followed by F. Press RUN UUT.
3. Increase the power supply output from zero until the green probe lamp just goes out. The level on the multimeter should be 0.8 ± 0.2 volts.
4. Continue to adjust the power supply output until the red probe lamp just lights. The multimeter should read 2.4 ± 0.2 volts.
5. If these levels are not met, proceed to the paragraphs titled Checking the Probe Logic.
6. Disconnect probe tip from power supply.

4-21. Probe Pulser Checks

4-22. Check for proper pulser operation as follows:

1. Set free-run sync by pressing SYNC followed by F.
2. Select PULSE LOW and verify that the green light on the probe flashes.
3. Select PULSE HIGH and deselect PULSE LOW; verify that the red light on the probe flashes.
4. Select both HIGH and LOW and verify that both lights flash.

4-23. Magnetic Tape Check

4-24. Check for proper magnetic tape operation as follows:

1. Install a blank tape (not write protected) into the tape drive and close the lid.
2. Press WRITE TAPE and ENTER/YES. The tape drive should rewind, write, rewind, read, and rewind. The 9010A should display WRITE TAPE OK.

4-25. Pod Connector Checks

4-26. Check the pod connector as follows:

1. Connect a known good interface pod to the 9010A and place the UUT connector of the pod into its self-test connector.

2. Press BUS TEST and verify the message xxxx-POD SELF-TEST OK appears (where xxxx indicates the interface pod type).

4-27. Display/Keyboard Check

4-28. Check the display/keyboard assembly as follows:

1. Key-in the programs listed in Table 4-2 and then execute program 0. Note that the PRGMING and EXECUTING annunciators light.
2. The display should read all "8"s and the STOPPED annunciator should light.
3. Press CONT and the display reads all *. Press CONT and all decimal points are displayed. Press CONT.
4. The display reads KEY=. Press all keys except STOP, LOW or HIGH and verify the hexadecimal value is the same as shown in Figure 4-3. Press STOP to exit program.

4-29. CALIBRATION ADJUSTMENTS**4-30. Power Supply Adjustment**

4-31. Adjustment (R2), shown in Figure 4-4, is provided for the +5-volt supply and should be adjusted to obtain a level of +5.0 volts ± 10 mV at TP10. For proper power supply loading, all assemblies should be connected to the Main Assembly.

4-32. Magnetic Tape Speed Adjustment

4-33. Tape speed can be checked and, if necessary, adjusted by means of the following procedure. Gain access to the Magnetic Tape Controller by removing the seven 9010A cover-retaining screws, removing the cover and to expose the Magnetic Tape Controller Assembly.

1. Open the cassette access door of the tape drive and place a strobe disk (part no. 609578 for 60 Hz operation, and part no. 609560 for 50 Hz operation) on the left spindle.
2. Power the 9010A off then on.
3. Select the read test by momentarily jumpering pins 20 and 22 of U1 on the magnetic tape controller assembly.
4. Observe the strobe disk while adjusting R14 (shown in Figure 4-5). The disk strobe lines appear motionless when proper speed is achieved.

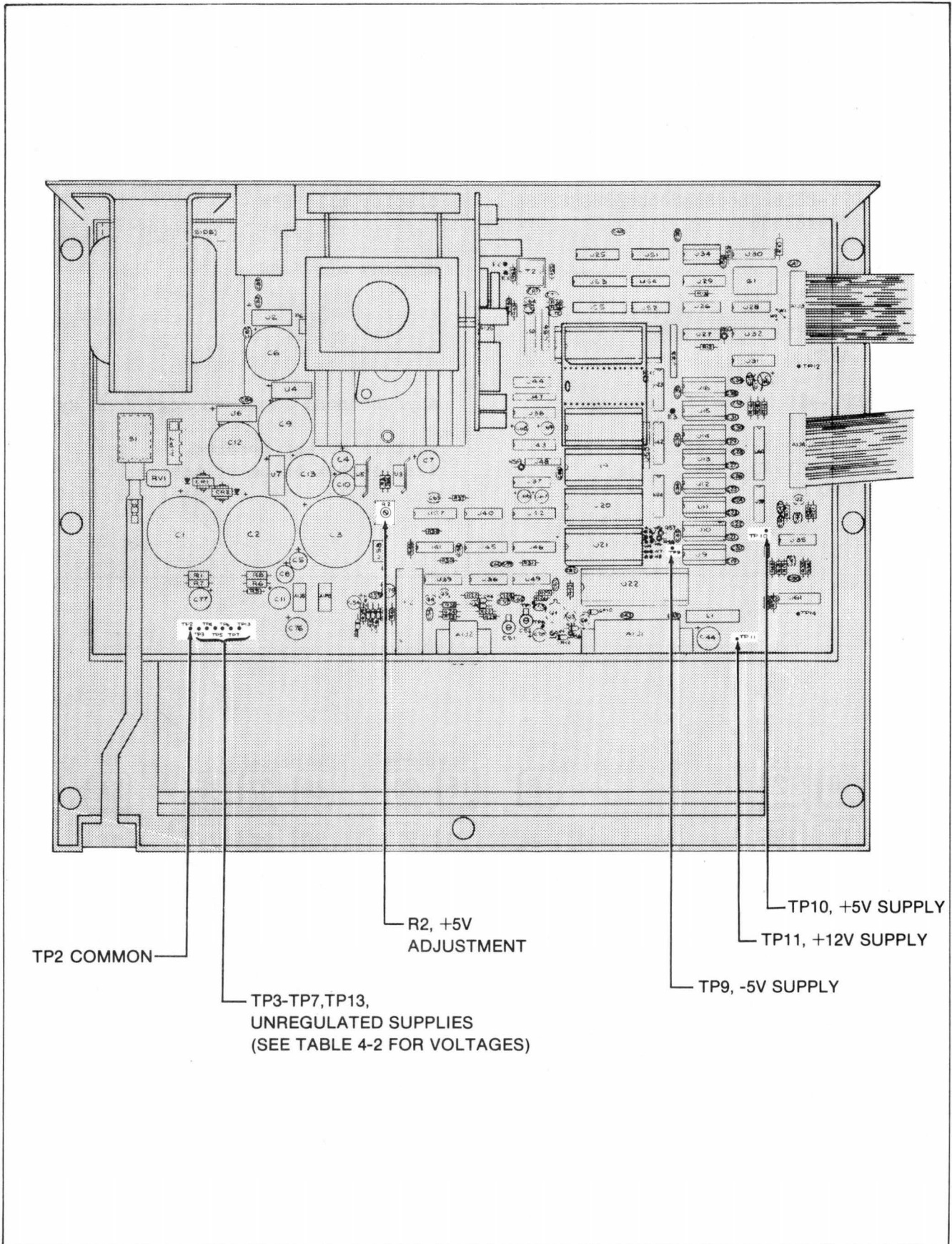

Figure 4-4. Power Supply Test Points and Adjustments

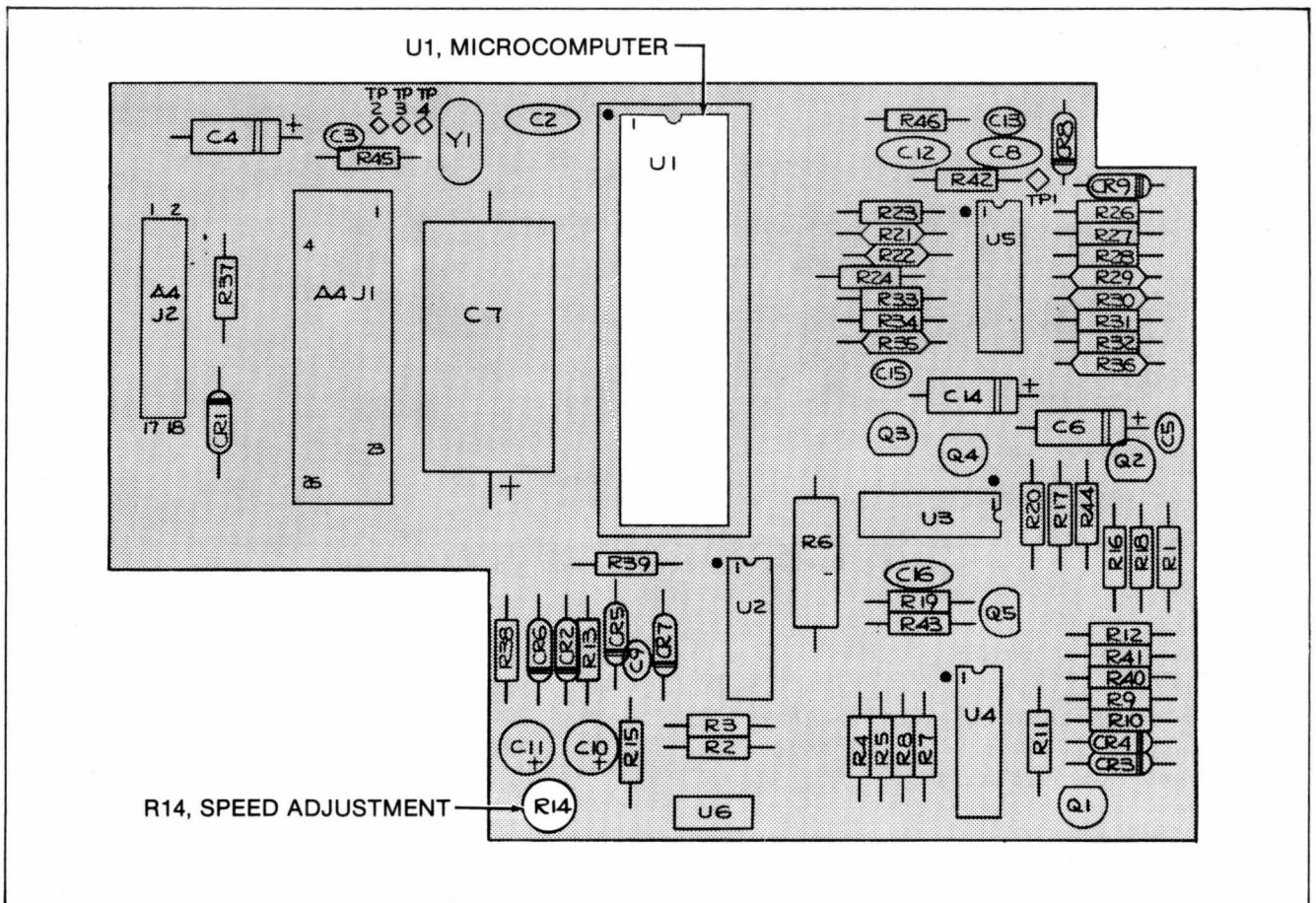

Figure 4-5. Tape Speed Adjustments

4-34. Probe Input Compensation Adjustment

4-35. Adjust probe input compensation as follows:

1. Gain access to the Main Assembly components as described under the heading Access Information.
2. Apply power to the troubleshooter and connect an oscilloscope across TP8 (ground) and TP14 located on the Main Assembly. Refer to Figure 4-6 for test point locations.
3. Adjust the oscilloscope to obtain a display of one or two full cycles of the signal at a vertical sensitivity of 2V/div.
4. Remove the oscilloscope from TP14 and connect to TP1 changing the vertical sensitivity to 100 mV/div.
5. Connect the probe cable to the underside front connector of the troubleshooter and connect the probe tip to TP14 and probe GND to TP8.

6. Adjust C51 and C52 (shown in Figure 4-6) to obtain best wave, i.e., square corners with minimum over or undershoot.

4-36. REPAIR PRECAUTIONS

CAUTION



Static discharge can damage MOS components contained in the troubleshooter. To prevent this possibility,

- Do not handle ICs or PCB assemblies by their connectors.
- Attach static ground straps to repair personnel.
- Use conductive foam to store replacement or removed ICs.
- Remove all plastic, vinyl and styrofoam from the work area.
- Use a grounded soldering iron.

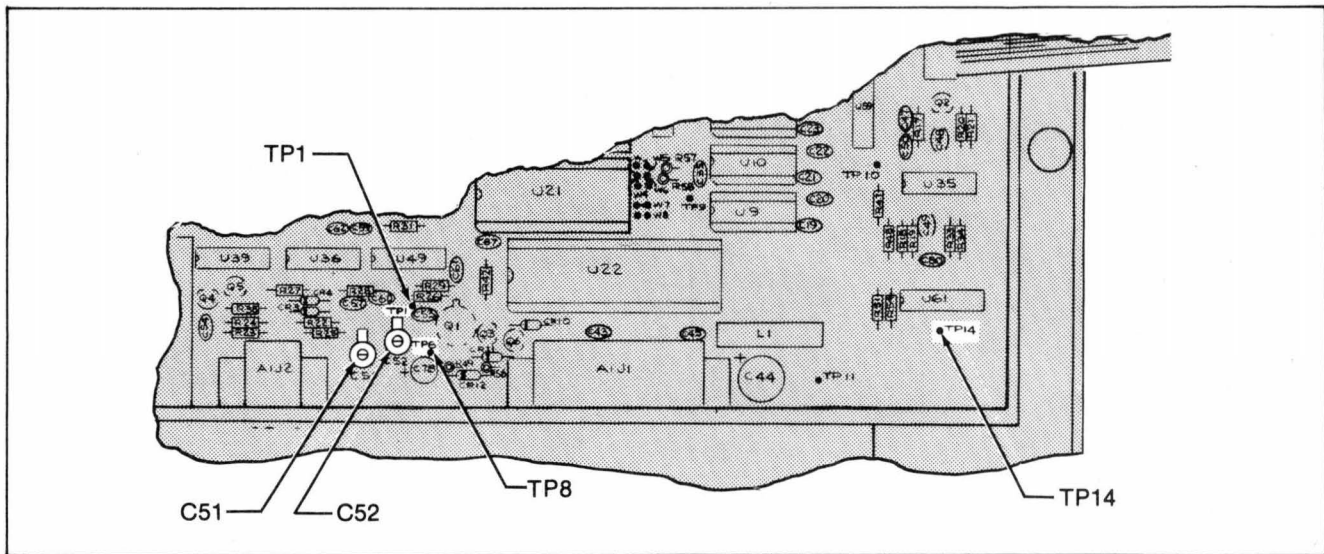

Figure 4-6. Probe Component Test Points and Adjustments

NOTE

The soldering iron used for repair should have a rating of 25 watts or less to prevent overheating the PCB assembly.

4-37. TROUBLESHOOTING

4-38. Introduction

4-39. Troubleshooting the 9010A is similar to troubleshooting any other microprocessor-based unit, and requires the equipment listed in Table 1-1. The troubleshooting information presented in the following paragraphs, plus the fault isolation diagram contained in Section 8 of this manual, provides a troubleshooting guide for use while employing normal fault isolation techniques. In addition, this section contains a series of test programs which can be run using a tester 9010A. These test programs are called out as required in the following troubleshooting procedures.

NOTE

All programs listed in the following sections are included as a starting point for troubleshooting a faulty 9010A. These programs could be expanded as the user becomes more sophisticated in troubleshooting techniques. The programs could also be adapted to the particular style of testing the user desires.

4-40. Power Supply Checks

4-41. Power supply levels should be checked whenever improper operation of the unit is suspected.

4-42. Using a digital multimeter, check the power supply voltages at the test points listed in Table 4-3 for the

listed levels. The location of the power supply test points and adjustment is shown in Figure 4-4. In order to maintain proper power supply loading, do not disconnect the Display/Keyboard Assembly from the Main Assembly. Failure of the unregulated supplies could be caused by a defective transformer (T1), open or shorted rectifier diodes, or open or shorted filter capacitors. Failure of the regulated supplies could be caused by defective regulator devices or shorts at the regulator outputs.

4-43. Ac ripple on all regulated supplies (except the 50-volt supply) is 25 millivolts rms maximum. The 50-volt supply typically contains less than 100 millivolts of ac ripple.

4-44. Bus/RAM/ROM Checks

4-45. Use a second 9010A Troubleshooter, hereafter referred to as the tester 9010A, and a 9000A-Z80 Interface Pod to perform all Main Assembly checks. Gain access to the Z80 socket by removing the seven retaining screws and the top cover from the 9010A. Lift off the top cover assembly and set to the side leaving the two ribbon cables attached. Connect the tester 9010A and the 9000A-Z80 Interface Pod to the main Assembly as follows:

1. With ac power off, and with reference to Figure 4-7, remove the ROM piggy-back bracket (not illustrated) and PCB assembly and the Z80 microprocessor (U8) from the Main Assembly.
2. Connect the 9010A-Z80 interface pod to the vacant Z80 socket and replace the ROM Piggy-Back Assembly, less the bracket.
3. With power applied first to the tester 9010A, apply power to the UUT (9010A under repair).

Table 4-3. Power Supply Test Points and Levels

POWER SUPPLY	UNREGULATED (Nominal Line Voltage)		REGULATED	
	TEST POINT	TYPICAL LEVEL	TEST POINT	NORMAL LEVEL V DC
+5V	TP3	+12.8V	TP10	+4.99 to 5.01
-5V	TP5	-14.7V	TP9	-4.75 to 5.25
+8V	TP7	+15.6V	TP13	+7.6 to 8.4
+12V	TP4	+23.1V	TP11	+11.4 to 12.6
+50V	TP6	+55V	---	---

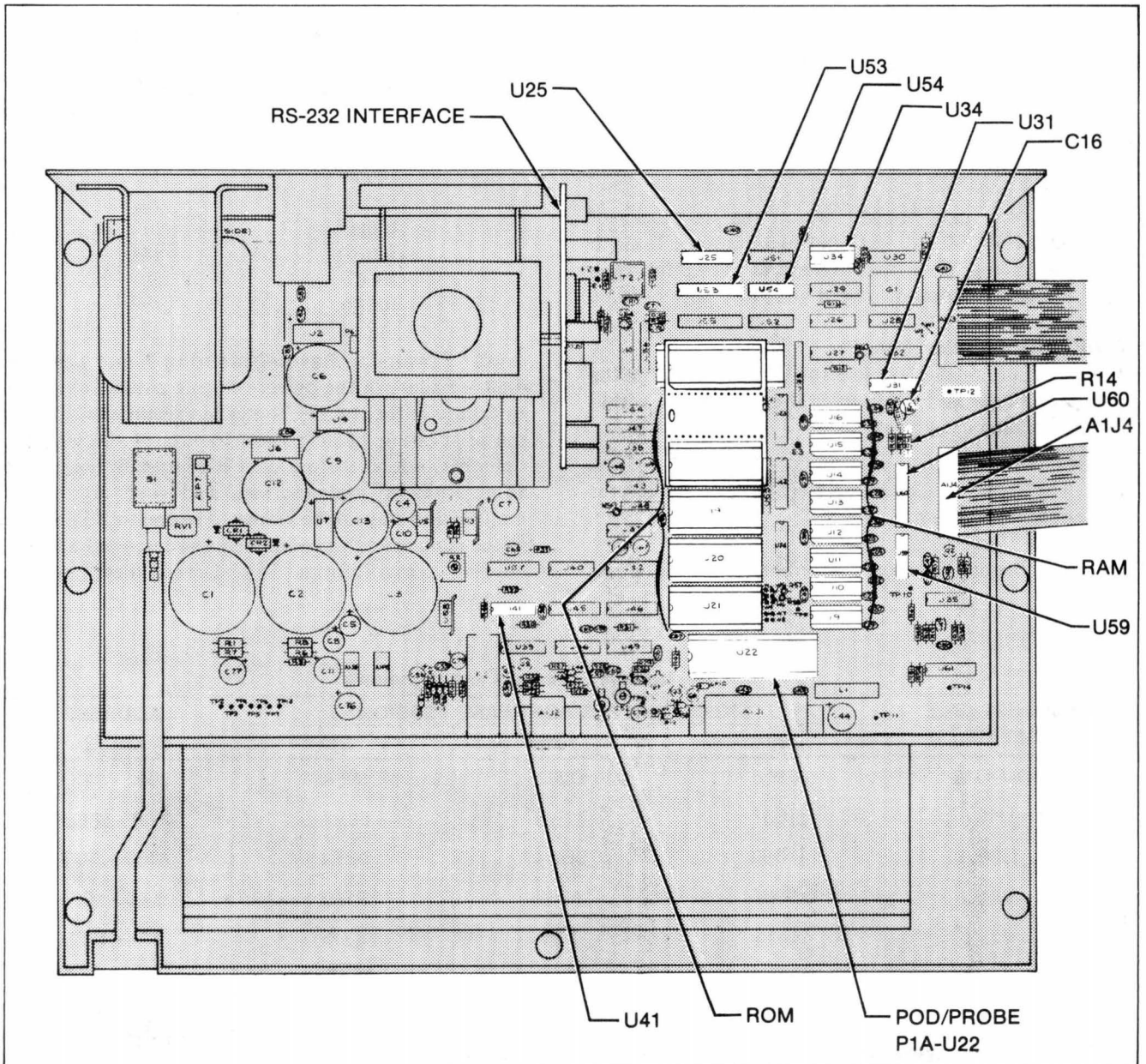

Figure 4-7. Main Assembly Components

4. Perform a Bus Test. If the test fails, examine the entire tester 9010A display diagnostic to determine the stuck line(s). Isolate any fault using the probe and schematic diagram contained in Section 8.

5. Perform a RAM Short test on address range C000 - FFFF; this test takes about 4 minutes and detects most types of RAM errors. A RAM Long test can also be performed, but allow approximately 67 minutes. RAM addresses are listed in Table 4-4.

NOTE

If a RAM failure occurs, carefully examine the diagnostic message. The RAM Test is usually sufficient for deducing the failed component directly.

6. To check the \overline{RAS} and \overline{CAS} signals of the RAM, use the probe synchronized to the address to trace the signals back through U29, U26, and U27 while performing a looping write to any RAM location.

7. Perform a ROM Test on the six blocks of ROM. ROM addresses and signatures are listed in Table 4-4. Note that signatures differ for each software version displayed at 9010A power-on.

4-46. I/O Selector Checks

4-47. Failure of the I/O selector U25 can result in the failure of any or all I/O devices. The I/O devices within the 9010A include:

- The Signature Generator/Event Counter - Selector outputs 0, 1, 2 and 3
- The Display/Keyboard Assembly - Selector output 4

- The Magnetic Tape Controller - Selector output 5
- The Pod/Probe PIA - Selector output 6
- The RS-232 Interface - Selector output 7

4-48. With the tester 9010A connected to the 9010A under test, hereafter referred to as the UUT, as described for Bus/RAM/ROM Checks, check the individual outputs of the I/O selector as follows:

1. Synchronize the tester 9010A probe to the address sync mode.
2. Perform looping-reads at each I/O selector address listed below, and use the probe to verify low signals at the corresponding outputs. Only oneline should be selected low at any given time.

I/O Address	U25 PIN NO.
10000	15
10020	14
10040	13
10060	12
10080	11
100A0	10
100C0	9
100E0	7

4-49. Power-On Reset/Watchdog Timer Checks

4-50. Failure of the power-on reset circuit is indicated by failure of the troubleshooter to execute self test upon the application of ac power. Failure of the watchdog timer may not be obvious since it is normally triggered by some internal malfunction, and such an internal malfunction may not be known to be present. Gain access to the main assembly components as described under the heading Access Information and check these circuits as follows:

Table 4-4. Memory Addresses and Signatures

ADDRESSABLE DEVICE	SIGNATURE PER SOFTWARE VERSION*			ADDRESS (HEX)
	2A	2B	1A	
ROM-U18	F906	C262	895A	2000 - 3FFF
-U19	1E37	72BC	F3AA	4000 - 5FFFF
U20	1B90	0BA4	9BE4	6000 - 7FFF
U21	9967	AF68	2140	8000 - 9FFF
U1**	651D	0295	8345	000 - 1FFF
U2**	0D0A	90C4	CFCA	A000 - BFFF
RAM	n/a	n/a	n/a	C000 - FFFF

*The software version installed in the 9010A is indicated on the display at power-on.

**Located on piggy-back ROM pcb.

1. With the tester 9010A connected to the 9010A under test as described for Bus/RAM/ROM Checks, select the Run UUT mode on the tester 9010A.

2. Using the tester 9010A probe in the sync-free-run pulse-low mode, momentarily connect the probe tip to U31-4 of the UUT. (Refer to Figure 4-7 for the location of U31.) The UUT should beep and display the power-up message FLUKE 9000 POWER-UP OK VER-xx (where xx indicates the current software version number) each time the probe is momentarily connected to U31.

3. Using the tester 9010A probe to read instead of pulse (pulse mode turned off), verify the presence of logic high levels at U31-4 and U31-7, and logic low at U31-6.

4. On the tester 9010A perform a looping-read or -write to address 10080 while observing U31-10 of the UUT with the tester 9010A probe (free-running). Press STOP on the tester 9010A and verify that the signal at U31-10 goes from high (red) to low (green) after approximately 4 seconds.

4-51. Pod/Probe PIA Checks

4-52. Failure of the pod/probe PIA typically causes communication problems with the pod and/or the probe since all commands and data move through the PIA. Using the following procedure, verify proper operation of the pod/probe PIA. (Figure 4-7 shows the location of the pod/probe PIA U22, U31, U34, and U25.)

1. Turn off the UUT and unplug the Display/Keyboard Assembly from the Main Assembly at A1J4.

2. Disable the watchdog timer U31 by jumpering R14 (the side adjacent to C16) to TP12 (ground). This removes the reset input from the pod/probe PIA and allows it to operate. Turn UUT power on.

3. Check the $\overline{CS2}$ input of the pod/probe PIA as follows:

a. Synchronize the tester probe to the address sync mode.

b. Performing a looping-read at address 100C0.

c. Check the $\overline{CS2}$ input at pin 23 of the PIA (U22), using the tester probe and if necessary at

pin 10 of U34 and pin 9 of I/O selector U25. Verify that all are logic low.

d. Check the \overline{EN} input at U22 pin 25, CS0 at U22 pin 23, and CS1 at U22 pin 24. Verify that all are logic high.

4. Check the data transfer operation of the PIA (U23) by keying-in programs 11 and 12 listed in Table 4-5 and executing program 11. The program prompts the user for yes/no answers. If a fault occurs, the user has the option to recheck that test or continue with the next test. Any test can be skipped by answering NO in response to the test.

4-53. Probe Related Circuit Checks

4-54. CHECKING THE PROBE LOGIC

4-55. The probe logic is divided into four distinct functions:

- Probe Level Detectors
- Free-run Probe Logic
- Synchronized Probe Logic
- Pulse Output

4-56. Checking each function of the probe logic is accomplished by running a short program on the tester 9010A (connected to the faulty 9010A by means of a 9000A-Z80 interface pod and the vacant microprocessor socket as described under the heading Bus/RAM/ROM Checks) in conjunction with some manual checks. It is assumed that the Pod/Probe PIA Checks have been performed and all tests passed.

4-57. Level Detector/Free-Run Checks

4-58. Perform level detectors/free-run checks as follows:

1. Turn off the UUT and remove the Display/Keyboard Assembly connector A1J4 (shown in Figure 4-7) to disable the beeper. Using a clip lead, disable the watchdog timer (U31) by jumpering R14 (the end adjacent to C16) to TP12 (gnd). Turn on the tester 9010A and then the UUT.

2. Verify correct operation of the probe logic in the free-running mode by keying-in programs 2, 12 and 14 listed in Table 4-6 and executing program 2. The program sets up the pod/probe PIA U22 to control the probe logic, and also uses the tester 9010A to verify that the probe logic circuits are operating properly in the UUT.

Table 4-5. PIA (U22) Test

PROGRAM LISTING	COMMENTS
<pre> PROGRAM 11 865 BYTES DPY-PIA TEST <U22># SYNC ADDRESS EXECUTE PROGRAM 12 DPY-JUMP R14//C16 TO TP2 OR TP1 DPY-+2-CONT# STOP REG1 = 0 1: LABEL 1 INC REG1 REG3 = 0 IF REG1 = 6 GOTO F IF REG1 = 5 GOTO 7 IF REG1 = 4 GOTO 4 IF REG1 = 3 GOTO 3 IF REG1 = 2 GOTO 2 DPY-#TEST PORT A OUTPUT EXECUTE PROGRAM 12 DPY-TESTER PULSE HIGH, LOW OUT- DPY-+CONT# STOP WRITE @ 100C1 = 0 WRITE @ REGF DEC = FF WRITE @ REGF INC = 4 REG2 = 2 REG6 = A00 REGF = 100C0 GOTO 5 2: LABEL 2 DPY-#TEST PORT B OUTPUT EXECUTE PROGRAM 12 WRITE @ 100C3 = 0 WRITE @ REGF DEC = FF WRITE @ REGF INC = 4 REG2 = 10 REG6 = A00 REGF = 100C2 GOTO 5 3: LABEL 3 DPY-TEST PORT A INPUT# EXECUTE PROGRAM 12 WRITE @ 100C1 = 0 WRITE @ REGF DEC = 0 WRITE @ REGF INC = 4 DPY-TESTER PULSE HIGH, LOW IN- DPY-+CONT# STOP REG2 = 2 REG6 = 1 REGF = 100C0 GOTO 5 </pre>	<pre> delay disable watchdog test number clear increment test number clear bit number which test is next? delay pia port a to output Part of Test 1 1st pia pin number expected signature pia port a address pia port b to output Part of Test 2 enter 1st pia pin number expected signature pia port b address pia port a to input Part of Test 3 1st pia pin number expected signature port a address </pre>

Table 4-5. PIA (U22) Test (cont)

PROGRAM LISTING	COMMENTS
<pre> 4: LABEL 4 DPY-TEST PORT B INPUT# EXECUTE PROGRAM 12 WRITE @ 100C3 = 0 WRITE @ REGF DEC = 0 WRITE @ REGF INC = 4 REG2 = 10 REG6 = 1 REGF = 100C2 5: LABEL 5 DPY-PROBE U22 PIN \$2 DPY-+, YES/NO #?? IF REG7 = 0 GOTO D READ PROBE IF REG1 = 5 GOTO 8 IF REG1 > 2 GOTO 6 WRITE @ REGF = 0 DTOG @ REGF = FF BIT REG3 DTOG @ REGF = REGE BIT REGD WRITE @ REGF = 0 READ PROBE IF REG0 AND FFFF00 = REG6 GOTO C GOTO E </pre>	<pre> pia port b to input Part of Test 4 1st pia pin number expected signature port b address does oper wish to probe current pia pin? no - increment pin and bit number yes - read probe if test 4 complete, check cb2 line if test 2 complete, continue with test 3, or 4 sets pia port to 0 toggle the bit no. in Part of reg. 3 Test 1 and 2 repeat toggle using default reg. pia to zero gather signature mask off all but sig and check against reg. 6 </pre>
<pre> 6: LABEL 6 READ @ REGF REG8 = REGE READ @ REGF IF REG8 AND REG6 = REGE AND REG6 GOTO E SHL REG6 GOTO C </pre>	<pre> read pulse at pia port Part save data of read pulse at pia port Test if pulse present 3 and 4 at each read, error move the test bit to next position for next pia pin check </pre>
<pre> 7: LABEL 7 DPY-#CB2 TEST EXECUTE PROGRAM 12 DPY-TESTER PULSE HIGH, LOW OUT- DPY-+CONT# STOP REG2 = 19 REG3 = 7 REG6 = 2 GOTO 5 </pre>	<pre> cb2 pin no. full count in bit counter expected event count </pre>

Table 4-5. PIA (U22) Test (cont)

PROGRAM LISTING	COMMENTS
<pre> 8: LABEL 8 WRITE @ 100C3 = 38 WRITE @ REGF = 30 WRITE @ REGF = 38 WRITE @ REGF = 30 READ PROBE IF REGO AND 7F = REG6 GOTO C GOTO E </pre>	<pre> stimulate cb2 line gather event count verify event count - o.k. goto a not correct count - goto e </pre>
<pre> C: LABEL C DPY--+, GOOD EXECUTE PROGRAM 12 </pre>	<pre> sig o.k. delay </pre>
<pre> D: LABEL D INC REG2 INC REG3 IF REG3 = 8 GOTO 1 GOTO 5 </pre>	<pre> increment pin increment bit </pre>
<pre> E: LABEL E DPY-#U22 PIN \$2 BIT \$3 FAILURE DPY--+ LOOP#?5 IF REG5 = 1 GOTO 5 DPY-TEST FAIL# STOP </pre>	<pre> sig. failure repeat test yes </pre>
<pre> F: LABEL F DPY-PIA TEST PASSED# </pre>	
<pre> PROGRAM 12 21 BYTES </pre>	<pre> delay approx. 1 second </pre>
<pre> REG1 = 40 1: LABEL 1 DEC REG1 IF REG1 > 0 GOTO 1 </pre>	

Table 4-6. Free-Running Probe Check

PROGRAM LISTING	COMMENTS
<pre> PROGRAM 2 768 BYTES DPY←FREE-RUN PROBE CHECK# SYNC FREE-RUN EXECUTE PROGRAM 12 DPY-JUMP R14//C16 TO TP2 OR TP1 DPY→+2-CONT# STOP 0: LABEL 0 DPY-SET INPUT >.8V AND <2.4V DPY→+ - CONT# STOP REG4 = 1 EXECUTE PROGRAM 14 IF REGE = 20 GOTO 1 DPY-INVALID STATUS GOTO E 1: LABEL 1 DPY-TESTER PROBE TO J2-6 - CONT DPY→+# STOP READ PROBE READ PROBE REG1 = 7000000 REG2 = 2000000 REG3 = 4000000 IF REG0 AND REG1 = REG2 GOTO 2 DPY-J2-6 INVALID GOTO E 2: LABEL 2 DPY-TESTER PROBE TO J2-9 - CONT DPY→+# STOP READ PROBE READ PROBE IF REG0 AND REG1 = REG2 GOTO 3 DPY-J2-9 INVALID GOTO E 3: LABEL 3 DPY-SET INPUT <.8V - CONT# STOP REG4 = 2 EXECUTE PROGRAM 14 IF REGE = 40 GOTO 4 DPY-LOW STATUS GOTO E 4: LABEL 4 DPY-TESTER PROBE TO J2-9 - CONT DPY→+# STOP READ PROBE READ PROBE IF REG0 AND REG1 = REG2 GOTO 5 DPY-J2-9 LOW GOTO E </pre>	<pre> delay disable watchdog timer invalid test pointer read uut probe level status check for invalid clear tester probe read tester probe probe level mask invalid mask low mask check for invalid clear tester probe read tester probe check for invalid low test pointer read uut probe level status check for low read tester probe, check for invalid </pre>

Table 4-6. Free-Running Probe Check (cont)

PROGRAM LISTING	COMMENTS
<pre> 5: LABEL 5 DPY-TESTER PROBE TO J2-6 - CONT DPY-+# STOP READ PROBE READ PROBE IF REG0 AND REG1 = REG3 GOTO 6 DPY-J2-6 LOW GOTO E 6: LABEL 6 DPY-SET INPUT >2.4V - CONT# STOP REG4 = 3 EXECUTE PROGRAM 14 IF REGE = 80 GOTO 7 DPY-HI STATUS GOTO E 7: LABEL 7 DPY-TESTER PROBE TO J2-6 - CONT DPY-+# STOP READ PROBE READ PROBE IF REG0 AND REG1 = REG2 GOTO 8 DPY-J2-6 HI GOTO E 8: LABEL 8 DPY-TESTER PROBE TO J2-9 - CONT DPY-+# STOP READ PROBE READ PROBE IF REG0 AND REG1 = REG3 GOTO F DPY-J2-9 HI GOTO E E: LABEL E DPY-+ FAULT - CONT# STOP IF REG4 = 1 GOTO 0 IF REG4 = 2 GOTO 3 IF REG4 = 3 GOTO 6 GOTO 0 F: LABEL F DPY-FREE-RUN PROBE LOGIC OK DPY-+# </pre>	<pre> read tester probe, check for low high test pointer read uut probe level status check for high status read tester probe/check for invalid read tester probe/check for low append to test error message </pre>
<pre> PROGRAM 12 21 BYTES REG1 = 40 1: LABEL 1 DEC REG1 IF REG1 > 0 GOTO 1 </pre>	<pre> delay approx. 1 second </pre>

Table 4-6. Free-Running Probe Check (cont)

PROGRAM LISTING	COMMENTS
<pre> PROGRAM 14 102 BYTES WRITE @ 100C3 = 30 WRITE @ 100C1 = 0 WRITE @ 100C0 = FF WRITE @ 100C1 = 4 WRITE @ 100C0 = 80 WRITE @ 100C3 = 38 WRITE @ 100C1 = 0 WRITE @ 100C0 = 0 WRITE @ 100C1 = 4 READ @ 100C0 REGE = REGE AND EO </pre>	<pre> cb2=0 pia port a to out free-run - pulse off cb2=1 pia port a to input read port a mask off all except level status </pre>

a. Before running the program, remove the UUT probe and connect to the probe input (at A1J2-2 or at R22) of the UUT to the positive output of a variable dc supply via a 100k, 1%, resistor. (Be sure to install the 100k resistor at the 9010A end of the dc supply test lead in order to prevent noise pick-up.) The negative input should be tied to TP8 (gnd). Also connect the tester probe as directed during program execution.

CAUTION

Do not allow the dc supply voltage to exceed 30 volts, or damage to the 9010A may result.

b. If an incorrect condition occurs, use the probe of the tester 9010A to isolate the fault. The tester display shows the test that failed.

c. Disconnect the dc supply and 100k resistor.

4-59. In general, the signal should be traced through the FET buffer Q1, to HIGH and LOW comparators U36 and U49, through U41 buffers, through flip-flops U37, through selector U38, through one-shot U42, and finally to S/R latches in U46. The reference levels at U36-3 (318 mV) and U49-4 (106 mV) should also be checked using a DVM. If a fault occurs at J2-6 or J2-9, troubleshoot U40, U44, U43 and Q4/Q5.

4-60. Synchronized Probe Check

4-61. Verify the probe input portion of the probe logic in the synchronized mode by keying-in the programs (3, 12, and 15) listed in Table 4-7 and executing program 3. This program sets up the pod/probe PIA U22 to control U45 and U38. To run the program, perform the following operations.

1. Connect the probe tip of a tester 9010A (to be used as a source of sync pulses) to U41, pin 9 of the UUT; connect the ground lead to TP8 (shown in Figure 4-7).

2. Run the program and connect the probe input (A1J2-2 or at R22) of the UUT to logic low (TP8 or TP2); verify the tester display indicates - LOW. Connect the probe to +5V (TP10); verify the tester display indicates - HIGH.

4-62. Probe Pulse Output Check

4-63. Verify the pulse output portion of the probe logic by keying-in programs 4, 12, and 13 listed in Table 4-8 and executing program 4. These programs set up the pod/probe PIA U22 to control U45, which enables U57, U37, U40, and U41. The program, and endless loop, also reads the output from the probe circuit and displays the pulse level on the tester 9010A. While running the program, observe that the lights of the UUT probe correspond to the tester 9010A display messages. Before running the check, remove all connections (except R14 to TP12) made for the previous tests and connect the UUT probe to its connector

4-64. CHECKING THE PROBE FUNCTIONS

4-65. The probe can be checked by substituting with a known good unit from a tester 9010A. If the problem appears to still exist, fault may be in the probe circuitry on the Main Assembly of the 9010A. Proceed to the section titled Checking the Probe Logic to locate the fault. If the probe is determined to be defective, proceed as follows to isolate the fault:

1. Remove the R14 to TP12 jumper connected in previous checks.

2. Press RUN UUT, ENTER/YES on the tester 9010A. Verify the UUT powers up normally.

Table 4-7. Synchronized Probe Check

PROGRAM LISTING	COMMENTS
<pre> PROGRAM 3 395 BYTES DPY-SYNC PROBE CHECK# EXECUTE PROGRAM 12 DPY-JUMP R14//C16 TO TP2 OR TP1 DPY-+2-CONT# STOP SYNC FREE-RUN DPY-TESTER PROBE TO UUT U41-9 DPY-+ - CONT# STOP 0: LABEL 0 DPY-TESTER PULSER OFF - CONT# STOP REG1 = 1 EXECUTE PROGRAM 15 IF REGE = 0 GOTO 1 DPY-SYNC GOTO E 1: LABEL 1 DPY-TESTER TO PULSE LOW -CONT# STOP 2: LABEL 2 REG1 = 2 DPY-CONNECT INPUT TO LOW<TP8> DPY-+ - CONT# STOP EXECUTE PROGRAM 15 IF REGE = 40 GOTO 3 DPY-LOW GOTO E 3: LABEL 3 REG1 = 3 DPY-CONNECT INPUT TO HI<TP10> DPY-+ - CONT# STOP EXECUTE PROGRAM 15 IF REGE = 80 GOTO F DPY-HI GOTO E E: LABEL E DPY-+ FAULT# STOP IF REG1 = 1 GOTO 0 IF REG1 = 2 GOTO 2 IF REG1 = 3 GOTO 3 GOTO 0 F: LABEL F DPY-SYNC PROBE LOGIC OK# </pre>	<pre> delay disable watchdog apply tester pulser to sync input of uut test 1 pointer read uut probe level status check for no low or high test 2 pointer read uut probe level status check for low test 3 pointer read uut probe level status check for high append to test message return to test 1, 2, or 3 </pre>

Table 4-7. Synchronized Probe Check (cont)

PROGRAM LISTING	COMMENTS
PROGRAM 12 21 BYTES REG1 = 40 1: LABEL 1 DEC REG1 IF REG1 > 0 GOTO 1 PROGRAM 15 101 BYTES WRITE @ 100C3 = 30 WRITE @ 100C1 = 0 WRITE @ 100C0 = FF WRITE @ 100C1 = 4 WRITE @ 100C0 = 0 WRITE @ 100C3 = 38 WRITE @ 100C1 = 0 WRITE @ 100C0 = 0 WRITE @ 100C1 = 4 READ @ 100C0 REGE = REGE AND C0 status	delay approx. 1 second cb2=0 pia port a to out sync mode/pulse off cb2=1 pia port a to input read port a mask off all except high/low probe

Table 4-8. Probe Pulse Output Check

PROGRAM LISTING	COMMENTS
PROGRAM 4 493 BYTES DPY-#PULSE OUTPUT CHECK EXECUTE PROGRAM 12 DPY-JUMP R14//C16 TO TP2 OR TP1 DPY-+2-CONT# STOP 0: LABEL 0 REG1 = 0 WRITE @ 100C3 = 30 WRITE @ 100C1 = 0 WRITE @ 100C0 = FF WRITE @ 100C1 = 4 WRITE @ 100C0 = 10 WRITE @ 100C0 = A0 WRITE @ 100C3 = 38 GOTO 3 1: LABEL 1 WRITE @ 100C3 = 30 WRITE @ 100C1 = 0 WRITE @ 100C0 = FF WRITE @ 100C1 = 4 WRITE @ 100C0 = C0 WRITE @ 100C3 = 38 GOTO 3	delay display watchdog cb2=0 pia port a to out beep pulse low/free-run cb2=1 free-run/high pulse

Table 4-8. Probe Pulse Output Check (cont)

PROGRAM LISTING	COMMENTS
<pre> 2: LABEL 2 WRITE @ 100C3 = 30 WRITE @ 100C1 = 0 WRITE @ 100C0 = FF WRITE @ 100C1 = 4 WRITE @ 100C0 = E0 WRITE @ 100C3 = 38 GOTO 3 </pre>	<pre> free-run/high & low pulse </pre>
<pre> 3: LABEL 3 WRITE @ 100C1 = 0 WRITE @ 100C0 = 0 WRITE @ 100C1 = 4 READ @ 100C0 INC REG1 REGE = REGE AND E0 IF REGE = 60 GOTO 4 IF REGE = A0 GOTO 5 IF REGE = E0 GOTO 6 GOTO 0 </pre>	<pre> pia port a to input read port a mask off all but probe level status check for low & invalid check for high & invalid check for low, invalid, high </pre>
<pre> 4: LABEL 4 DPY-#PULSE LOW <GREEN> EXECUTE PROGRAM 13 IF REG1 = 1 GOTO 1 IF REG1 = 2 GOTO 2 GOTO 0 </pre>	
<pre> 5: LABEL 5 DPY-PULSE HIGH <RED># EXECUTE PROGRAM 13 IF REG1 = 1 GOTO 1 IF REG1 = 2 GOTO 2 GOTO 0 </pre>	
<pre> 6: LABEL 6 DPY-#PULSE HIGH AND LOW <BOTH> EXECUTE PROGRAM 13 IF REG1 = 1 GOTO 1 IF REG1 = 2 GOTO 2 GOTO 0 </pre>	
<pre> PROGRAM 12 21 BYTES </pre>	<pre> delay approx. 1 second </pre>
<pre> REG1 = 40 1: LABEL 1 DEC REG1 IF REG1 > 0 GOTO 1 </pre>	
<pre> PROGRAM 13 14 BYTES EXECUTE PROGRAM 12 EXECUTE PROGRAM 12 EXECUTE PROGRAM 12 </pre>	<pre> delay approx. 3 seconds </pre>

3. Verify the signal path from the probe tip to the 9010A as follows:

- a. Connect the defective UUT probe to the UUT 9010A, and the probe tip to the points listed in the following table (UUT pulse should be off).
- b. Using the good probe of the tester 9010A, check the levels at U36-11 and U49-11 located on the main assembly to be as follows. (Ground both probe leads to TP12.)

UUT PROBE INPUT	U36-11 LEVEL	U49-11 LEVEL
5V (TP10)	LOGIC LOW	LOGIC HIGH
GND (TP12)	LOGIC HIGH	LOGIC LOW
OPEN	LOGIC HIGH	LOGIC HIGH

4. Disassemble the probe by unscrewing and withdrawing the rear portion back along the cable. Lift off the probe case half to expose the lamps and printed circuit board assembly.

NOTE

To further disassemble the probe for the purpose of repair, unscrew the ground lead and unsolder the circuit board from the tip.

5. Verify proper operation of the probe lamps by connecting the UUT probe to the points listed in the following table and observing the lamps. If the lamps do not light in accordance with the table, check that the lamp(s) are not burned out, and verify their connection to pins 6 and 9 of the probe connector. Also check that +5V appears in pin 4 of the connector located on the UUT.

PROBE INPUT	RED LAMP	GREEN LAMP
+5V (TP10)	ON	OFF
GND (TP12)	OFF	ON
OPEN	OFF	OFF

6. To verify operation of the output pulse circuit of the probe, select HIGH and LOW pulses on the UUT and observe the lamps. Both lamps should flash. If the lamps do not flash, connect the UUT probe to the probe of the tester 9010A. If the lamps of the tester 9010A probe do not flash, check the +5 volts supply to the probe; also check drivers Q1 and Q2 within the probe and their connections to pins 3 and 7 of the probe connector. If the lamps of the tester 9010A probe do flash, perform the Probe Level Detection/Verification.

4-66. Signature Register Checks

4-67. A check of the signature register may be made if the UUT displays inconsistent or incorrect signatures for known-good UUTs. Connect the tester 9010A to the UUT as described under the heading Bus/RAM/ROM Checks. To check the signature counter, shown in sheet 4 of the Main Assembly schematic, key-in programs 5 and 12 listed in Table 4-9 and execute program 5. During program execution, follow the instructions on the tester 9010A display; press CONT after each messages.

NOTE

The Signature Register Test program (listed in Table 4-9) uses the tester 9010A probe to generate sync pulses to the UUT signature register. The program also verifies the correct data after shifting a "1" bit through the register.

4-68. Event Counter Checks

4-69. A check of the event counter circuit should be made if the troubleshooter displays inconsistent or incorrect counts for known-good UUTs. Check the event counter, U59 and U60, shown in sheet 4 of the Main Assembly schematic and in Figure 4-7, as follows:

- 1. Be sure the UUT probe is connected.
- 2. Key-in programs 9 and 12 listed in Table 4-10 and execute program 9.
- 3. Repeat execution of the program by pressing the REPEAT key. If the counter test fails, note the bit in error and replace the appropriate device, U59 or U60.

4-70. Display/Keyboard Checks

4-71. The Display/Keyboard Assemblies contain resident test programs which provide for complete testing of both assemblies. These tests can be performed at any time without the need for a tester 9010A by removing the 9010A Troubleshooter cover and lifting out the Display/Keyboard Assembly. Orient the Display/Keyboard Assembly so that the test points shown in Figure 4-8 are accessible and the display is visible. Apply power to the UUT, jumper R14/C16 to TP2 on the Main Assembly to disable watchdog timer and then perform the following tests as required.

4-72. DISPLAY SEGMENT TEST

4-73. The display segment test causes each segment of each display character to sequentially light. The free-running probe of a tester 9010A can be used to verify segment data to the display via U11, U12, U13 and U14. To initiate the display segment test, momentarily jumper TP5 (ground) to TP0 (located on the Display Assembly); or, if the UUT is connected to a tester 9010A, perform WRITE @ 10081 = 00, followed by WRITE @ 10081 = 01.

Table 4-9. Signature Register Test

PROGRAM LISTING	COMMENTS
<pre> PROGRAM 5 460 BYTES DPY-SIGNATURE REGISTER CHECK DPY-+# EXECUTE PROGRAM 12 SYNC DATA DPY-JUMP R14//C16 TO TP2 OR TP1 DPY-+2-CONT# STOP DPY-TESTER PROBE TO U41-9 DPY-+, CONT# STOP DPY-TESTER PULSE OFF - CONT# STOP DPY-UUT PROBE TO TP10<+5V> DPY-+, CONT# STOP WRITE @ 100C3 = 30 WRITE @ 100C1 = 0 WRITE @ 100C0 = FF WRITE @ 100C1 = 4 WRITE @ 100C0 = 80 WRITE @ 100C3 = 38 READ @ 10020 DPY-PRESS PULSE LOW ON TESTER DPY-+, CONT# STOP REG1 = 0 REGF = 10040 1: LABEL 1 READ @ REGF INC REG1 IF REG1 = 9 GOTO 2 GOTO 1 2: LABEL 2 IF REGE = FE GOTO 3 DPY-SIGNATURE ERROR-LO BYTE STOP GOTO F 3: LABEL 3 REG1 = 0 REGE = 0 REGF = 10060 4: LABEL 4 READ @ REGF INC REG1 IF REG1 = 8 GOTO 5 GOTO 4 5: LABEL 5 IF REGE = FE GOTO F DPY-SIGNATURE ERROR-HI BYTE STOP F: LABEL F DPY-SIGNATURE TEST COMPLETE </pre>	<pre> delay disable watchdog setup info cb2=0 port a to output free-run/pulse off cb2=1 reset signature/event counter sig. lo byte address 9 clks to sig. register check lo-byte sig. high byte address 8 clks to sig register check high-byte </pre>

Table 4-9. Signature Register Test (cont)

PROGRAM LISTING	COMMENTS
<pre> PROGRAM 12 21 BYTES REG1 '= 40 1: LABEL 1 DEC REG1 IF REG1 > 0 GOTO 1 </pre>	<p>delay approx. 1 second</p>

Table 4-10. Event Counter Test

PROGRAM LISTING	COMMENTS
<pre> PROGRAM 9 347 BYTES SYNC DATA DPY-#EVENT COUNTER TEST EXECUTE PROGRAM 12 DPY-JUMP R14//C16 TO TP2 OR TP1 DPY-+2-CONT# STOP DPY-UUT PROBE TO +5V<TP10>-CONT DPY-+# STOP DPY-TESTER PROBE TO U59-1-CONT# STOP DPY-TESTER TO PULSE OFF - CONT# STOP READ @ 10020 DPY-TESTER TO PULSE LOW-CONT# STOP REG2 = 0 0: LABEL 0 READ @ 10000 REGE = REGE AND 7F INC REG2 DPY-DATA READ = \$E IF REG2 = 80 GOTO 1 IF REGE = REG2 GOTO 0 DPY-DATA = \$E SHOULD BE = \$2 DPY-+ - CONT# STOP DPY-CHECK U59 AND U60 STOP 1: LABEL 1 DPY-END OF EVENT COUNTER CHECK PROGRAM 12 21 BYTES REG1 = 40 1: LABEL 1 DEC REG1 IF REG1 > 0 GOTO 1 </pre>	<p>delay disable watchdog</p> <p>setup instructions</p> <p>reset event counter</p> <p>initialize count</p> <p>read event counter mask off fuse blown bit increment count</p> <p>count = 80 - done check - is hardware event count (rege) = soft count (reg2)</p> <p>delay approx. 1 second</p>

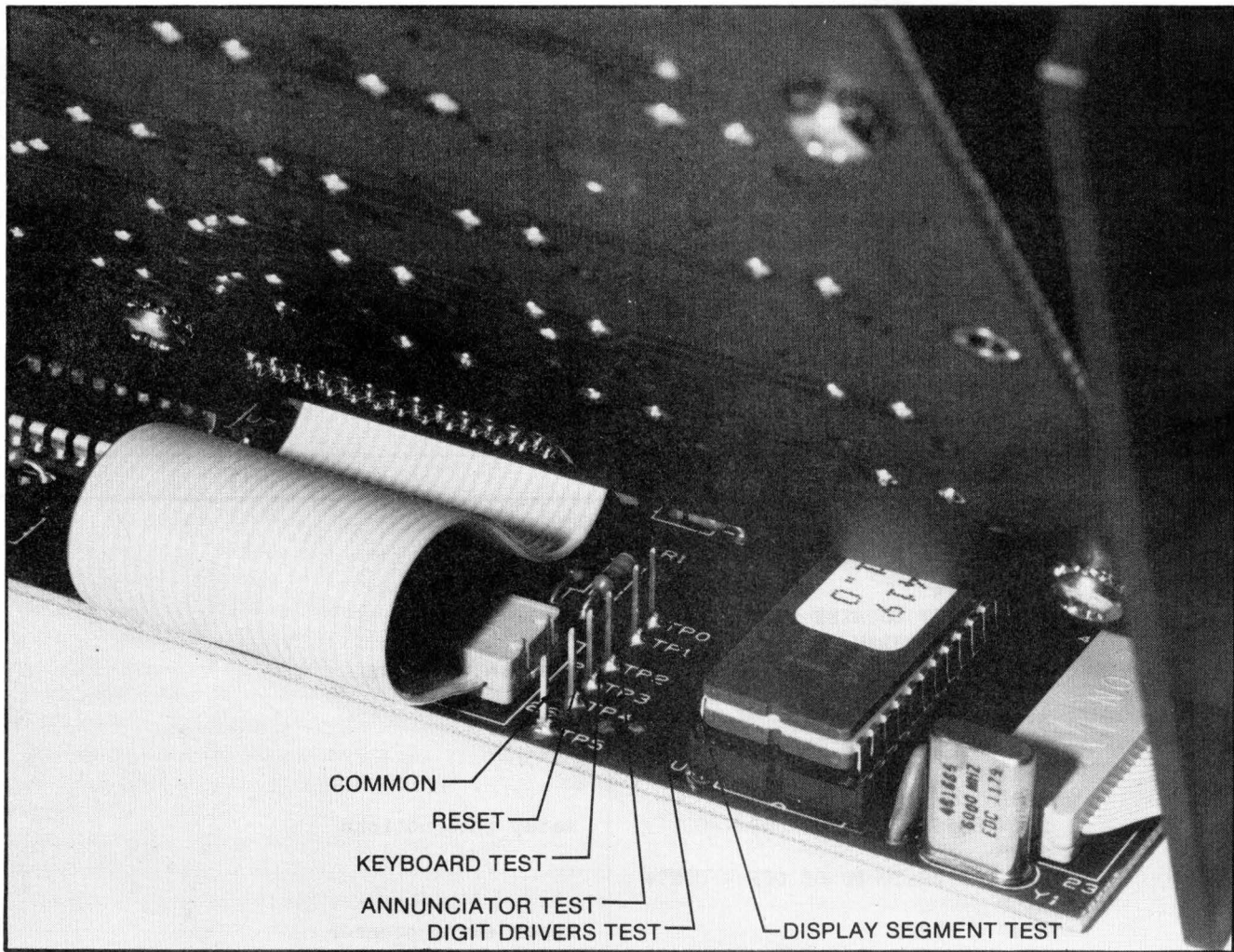

Figure 4-8. Display/Keyboard Self-Test Points

4-74. DISPLAY DIGIT DRIVERS TEST

4-75. The digit drivers test creates an all-segment character and walks the character across the entire display. The free-running probe of the tester 9010A can be used to verify digit driver signals at U3, U4, U5, U6, U7, U8, U9, and U10. To initiate the digit drivers test, momentarily jumper TP5 (ground) to TP1 (located on the Display Assembly) or, if the UUT is connected to a tester 9010A, perform WRITE @ 10081 = 00, followed by WRITE @ 10081 = 02.

4-76. DISPLAY ANNUNCIATOR TEST

4-77. The annunciator test causes the MORE, STOPPED, and EXECUTING annunciators to flash when the PULSE HIGH switch is depressed and the LOOPING and PROGRAMING annunciators to flash when the PULSE LOW switch is depressed. To initiate the annunciator test, momentarily jumper TP5 (ground) to TP2 (located on the Display Assembly) or, if the UUT is connected to a tester 9010A, perform WRITE @ 10081 = 00, followed by WRITE @ 10081 = 04.

4-78. KEYBOARD TEST

4-79. The keyboard test, when initiated, writes the segment pattern shown in Figure 4-9 to the display. Initiate the keyboard test by momentarily jumpering TP5 (ground) to TP3 (located on the Display Assembly) or, if the UUT is connected to a tester 9010A, perform WRITE @ 10081 = 00, followed by WRITE @ 10081 = 08. Note the following:

- As each key (except HIGH and LOW) is pressed, the corresponding portion of the display goes out. Pressing all keys results in a blank display. Refer to Figure 4-9 and Table 4-11 for key/switch identification.
- A shorted key causes the corresponding portion of the display to remain blank when initiating the test.
- If two or more keys are shorted, two or more portions of the pattern go out when one of the keys is pressed.

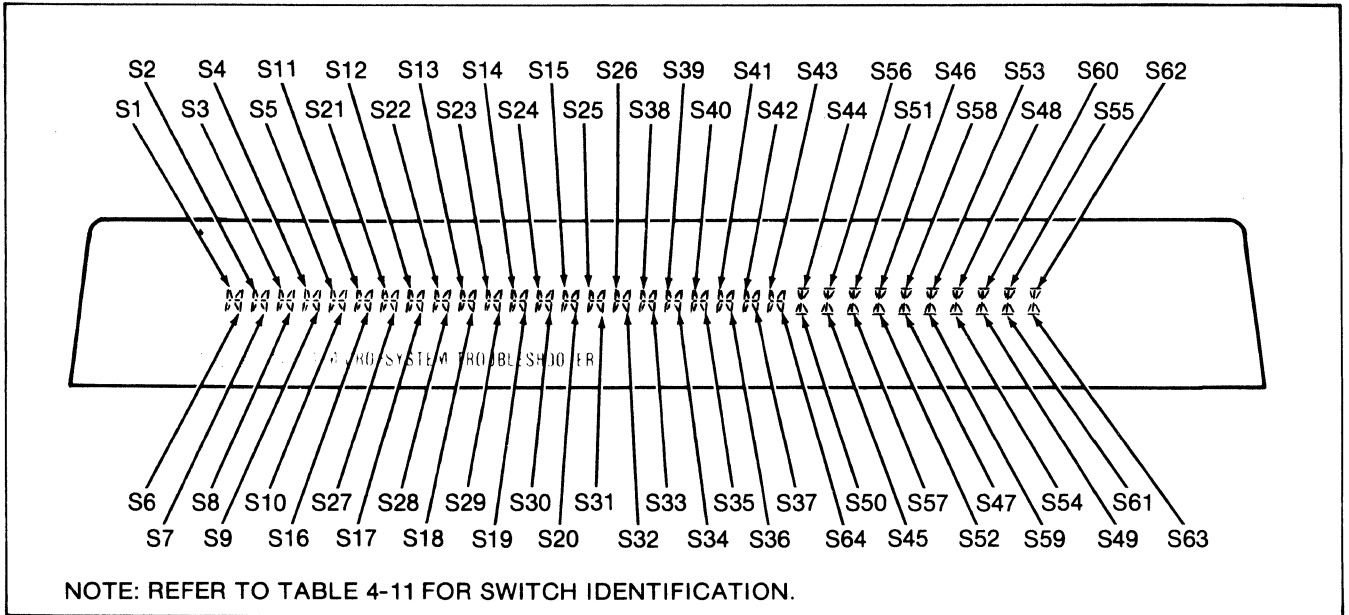

Figure 4-9. Keyboard Test Pattern

Table 4-11. Keyboard Switch Identification

SWITCH	KEY NAME	SWITCH	KEY NAME	SWITCH	KEY NAME
S1	LEARN	S23	6/0110	S45	IF
S2	VIEW RAM	S24	2/0010	S46	DISPL
S3	AUTO TEST	S25	PRIOR	S47	AND
S4	BUS TEST	S26	STS/CTL	S48	OR
S5	ROM TEST	S27	F/1111	S49	READ PROBE
S6	VIEW I/O	S28	B/1011	S50	EXEC
S7	VIEW ROM	S29	7/0111	S51	>
S8	RAM LONG	S30	3/0011	S52	LABEL
S9	RAM SHORT	S31	MORE	S53	SHIFT LEFT
S10	I/O TEST	S32	READ	S54	SHIFT RIGHT
S11	C/1100	S33	RAMP	S55	REG
S12	8/1000	S34	TOGGL ADDR	S56	AUX I/F
S13	4/0100	S35	CONT	S57	=
S14	0/0000	S36	REPEAT	S58	GOTO
S15	ENTER/YES	S37	LOOP	S59	INCR
S16	D/1101	S38	WRITE	S60	DECR
S17	9/1001	S39	WALK	S61	COMPL
S18	5/0101	S40	TOGGL DATA	S62	READ TAPE
S19	1/0001	S41	STOP	S63	WRITE TAPE
S20	CLEAR/NO	S42	RUN UUT	S64	PROBE SYNC
S21	E/1110	S43	SET UP	S65	PULSE HIGH
S22	A/1010	S44	PROGM	S66	PULSE LOW

- An open switch causes a portion of the pattern to remain.

4-80. DISPLAY/KEYBOARD RESET

4-81. To reset the Display/Keyboard Assembly, momentarily jumper TP5 (ground) to TP4 (located on the Display Assembly) or, if the UUT is connected to a tester 9010A, perform WRITE @ 10081 = 00, followed by WRITE @ 10081 = 00.

4-82. DISPLAY KEYBOARD COMMUNICATION CHECKS

4-83. Communication between the microprocessor and the display/keyboard peripheral microcomputer may be checked by keying-in programs 6, 12, and 13 listed in Table 4-12 and executing program 6. The program verifies that the main microprocessor is able to communicate with the peripheral microcomputer by attempting to write data to the display and read data from the keyboard. In addition, proper operation of the status registers are verified and also the self-test commands are checked for proper operation.

4-84. Magnetic Tape Controller

4-85. The Magnetic Tape Controller contains resident test programs which provide testing of the controller and tape drive. These tests can be performed at any time without the need for a tester 9010A by removing the troubleshooter cover and inverting it to expose the Magnetic Tape Controller shown in Figure 4-5. Apply power to the troubleshooter and perform any or all of the following tests.

4-86. SELF TEST

4-87. Initiate self test by removing and reapplying power to the 9010A and then momentarily jumpering pins 20 (ground) and 21 ($\overline{\text{SLFTST}}$) of microcomputer U1 on the Magnetic Tape Assembly. (Be sure to use a blank tape, or one that contains old data and is not write-protected.) The self test causes the controller to perform the following functions:

- Rewind the tape
- Write one thousand words of known data
- Rewind the tape
- Read and check the written data
- Stops upon the detection of any read error
- Repeats the entire sequence until reset by jumpering pins 20 and 4 of microcomputer U1

4-88. If the magnetic tape drive stops during the self test, a failure is indicated. Perform the read and write tests in order to isolate the fault. If the magnetic tape drive passes

the read and write tests, perform the checks presented under the heading Magnetic Tape Communications Checks.

4-89. MAGNETIC TAPE READ TEST

4-90. Initiate the read test by momentarily jumpering pins 20 and 22 ($\overline{\text{RDTST}}$) of microcomputer U1. The read test causes the controller to perform the following functions:

- Rewind the tape
- Operate the tape drive in the read mode
- If a cassette is installed, rewinds at end-of-tape and repeats the read operation

4-91. During performance of the read test, make the following checks:

1. During the rewind portion of the read test, check for approximately +4.8V (solenoid voltage) at A4J2, pin 14; approximately +0.2V (+ motor voltage) at A4J2, pin 17; and approximately +4.8V (- motor voltage) at A4J2, pin 18. If any voltage is not correct, trace the signal from U1, pin 33, (REWD) through U2 and U4 to locate the fault. Also verify that the solenoid pulls in during rewind.

2. Using an oscilloscope, verify that U1, pin 27 (CLEAR LEADER) is high just as the tape starts forward and is still on clear leader, and then drops low. Also observe a low 20 ms pulse as the start-of-tape hole passes over the optical sensing path. If these signals do not occur, check Q5; verify that the LED conducts by measuring voltage drop across R38; and check that A4J2, pin 8 (PHOTO XSTR) drops low when on clear leader. If all active devices appear normal, check alignment of the optical path.

3. During forward read, the Motor (+) voltage (A4J2-17) should be at approximately +4.8V dc. If not, check the Forward signal from U1-32 through U2-A and transistor U4B. The Motor (-) (A4J2-18) should measure approx 2.5V dc. If not check U6 and its related components.

4. Using a tape with data already recorded and a storage type oscilloscope, verify the waveforms at U5A-1, U5D-14, U5C-8 and U5B-7 against those shown in Figure 4-10. Be sure to note the voltage levels. Be sure the Head(+) (A4J2-3) and Head(-) (A4J2-4) wires are connected. If the proper signals are not present, a faulty U5 or an open resistor is indicated. Be sure to check that the signal at U5B-8 is also present at U1-39.

5. Verify that U1-27 is logic low with a cassette installed and logic high when the tape lid is open.

Table 4-12. Display/Keyboard Communication Check

PROGRAM LISTING	COMMENTS
<pre> PROGRAM 6 1395 BYTES WRITE @ 10081 = FF READ @ 10080 REPT DPY-DISPLAY/KYBD COMM. CHECK EXECUTE PROGRAM 12 DPY-JUMP R14//C16 TO TP2 OR TP1 DPY-+2-CONT# STOP 0: LABEL 0 READ @ 10080 DPY-HIT UUT 'WRITE' - CONT# STOP READ @ 10081 IF REGE AND 1 = 1 GOTO 1 DPY-#BAD STATUS BIT 0 <NO KEY> DPY-+-CONT STOP GOTO 0 1: LABEL 1 READ @ 10080 DPY-HIT UUT 'RAMP' - CONT# STOP READ @ 10080 IF REGE = 21 GOTO 2 DPY-READ DATA FAILURE - CONT# STOP GOTO 1 2: LABEL 2 DPY-#HIT UUT 'READ' TWICE, CONT STOP READ @ 10081 IF REGE AND 80 > 0 GOTO 3 DPY-#BAD STATUS BIT 7, NO OVER DPY-+RUN STOP GOTO 2 3: LABEL 3 DPY-TEST STATUS BIT 3=0 <CTRL># EXECUTE PROGRAM 13 WRITE @ 10081 = FF READ @ 10081 IF REGE AND 8 = 0 GOTO D DPY-#TEST STATUS BIT 3=1 <DATA> EXECUTE PROGRAM 13 WRITE @ 10080 = AA READ @ 10081 IF REGE AND 8 > 0 GOTO D WRITE @ 10081 = CO DPY-DISPLAY U'S LEFT-TO-RIGHT# REG2 = 0 WRITE @ 10081 = 20 </pre>	<pre> reset display/kybd clear out buffer delay disable watchdog clear buffer read status check - buffer full - yes no - error repeat status check buffer - full clear buffer read kybd check for 'ramp' key - yes not correct data repeat test read data passes read status overrun bit set - yes overrun bit not set - fail repeat test delay reset read status last command "control"?- fail goto d write data read status last command "data"?- fail goto d clear display digit counter pointer to left most digit </pre>

Table 4-12. Display/Keyboard Communication Check (cont)

PROGRAM LISTING	COMMENTS
<pre> 4: LABEL 4 WRITE @ 10080 = 55 INC REG2 IF 20 > REG2 GOTO 4 DPY-#ALL U'S - YES//NO?0 IF REGO = 0 GOTO E DPY-DISPLAY *. RIGHT-TO-LEFT# REG3 = 20 5: LABEL 5 REG2 = REG3 DEC WRITE @ 10081 = 20 OR REG2 WRITE @ 10080 = AA DEC REG3 IF REG3 > 0 GOTO 5 DPY-#ALL *. 'S - YES//NO?0 IF REGO = 0 GOTO E DPY-#FLASH EACH DIGIT REG2 = 0 6: LABEL 6 WRITE @ 10081 = 60 OR REG2 INC REG2 IF 20 > REG2 GOTO 6 WRITE @ 10081 = 80 DPY-+#-YES//NO?0 IF REGO = 0 GOTO C DPY-BLANK DISPLAY TWICE# WRITE @ 10081 = DF EXECUTE PROGRAM 12 WRITE @ REGF = DF DPY-+#-YES//NO?0 IF REGO = 0 GOTO C DPY-#MASTER RESET TEST EXECUTE PROGRAM 13 WRITE @ 10081 = FF DPY-# DPY-DISPLAY BLANK-YES//NO?0 IF REGO = 0 GOTO C DPY-#LIGHT ALL LED'S WRITE @ 10081 = 5F DPY-+#-YES//NO?0 IF REGO = 0 GOTO C DPY-#SINGLE SEGMENT TEST CMD WRITE @ 10081 = 00 WRITE @ REGF = 1 DPY-+-OK?0 IF REGO = 0 GOTO C </pre>	<pre> write a "u" and increment (shift right) one digit increment digit counter > than decimal 32 goto 4 user checks for all u's - if no goto e digit counter to right most set digit pointer = let most digit + dec. value of reg 2 to right write a ".*" to display; move pointer to right 1 digit decrement digit counter dme - go to 5 user checks for all ".*"'s - if not goto e flash pointer set flash mode - position = leftmost + dec. value of reg 2 inc. flash position flushed all characters turn off flash mode user verifies all char flashed - if no goto c blank display (31 scans) delay blank display (31 scans) user verifies display blanked - if no goto c master reset user verifies display went blank - if no goto c light all leds user verifies display went blank - if no goto c reset test start seg. test user verifies test started - if no goto c </pre>

Table 4-12. Display/Keyboard Communication Check (cont)

PROGRAM LISTING	COMMENTS
<pre> DPY-#WALKING CHARACTER TEST CMD WRITE @ 10081 = 0 WRITE @ REGF = 2 DPY--+OK?0 IF REGO = 0 GOTO C WRITE @ 10081 = 0 DPY-HIT UUT PULSE LOW AND HIGH- DPY-+CONT# STOP DPY-#LED TEST COMMAND WRITE @ REGF = 4 DPY-+ #-ALL LEDS ON?0 IF REGO = 0 GOTO C DPY-UUT PULSE HIGH AND LOW OFF- DPY-+CONT# STOP DPY-#KEY TEST CMND WRITE @ 10081 = 0 WRITE @ REGF = 8 DPY-+ #-STARTED?0 IF REGO = 0 GOTO C GOTO F C: LABEL C DPY-WRITE CMND FAIL-CONT# STOP GOTO 3 D: LABEL D DPY-#BAD STATUS BIT 3 <\$E> STOP GOTO 3 E: LABEL E DPY-WRITE DATA FAIL-CONT# STOP GOTO 3 F: LABEL F DPY-DISPLAY/KYBD TEST COMPLETE WRITE @ 10081 = FF </pre>	<pre> reset test start walk. char. test user verifies test started - if no goto c reset test start led test user verifies test started - if no goto c reset test start key test user verifies test started - if no goto c </pre>
<pre> PROGRAM 12 21 BYTES REG1 = 40 1: LABEL 1 DEC REG1 IF REG1 > 0 GOTO 1 </pre>	<pre> delay approx. 1 second </pre>
<pre> PROGRAM 13 14 BYTES EXECUTE PROGRAM 12 EXECUTE PROGRAM 12 EXECUTE PROGRAM 12 </pre>	<pre> delay approx. 3 seconds </pre>

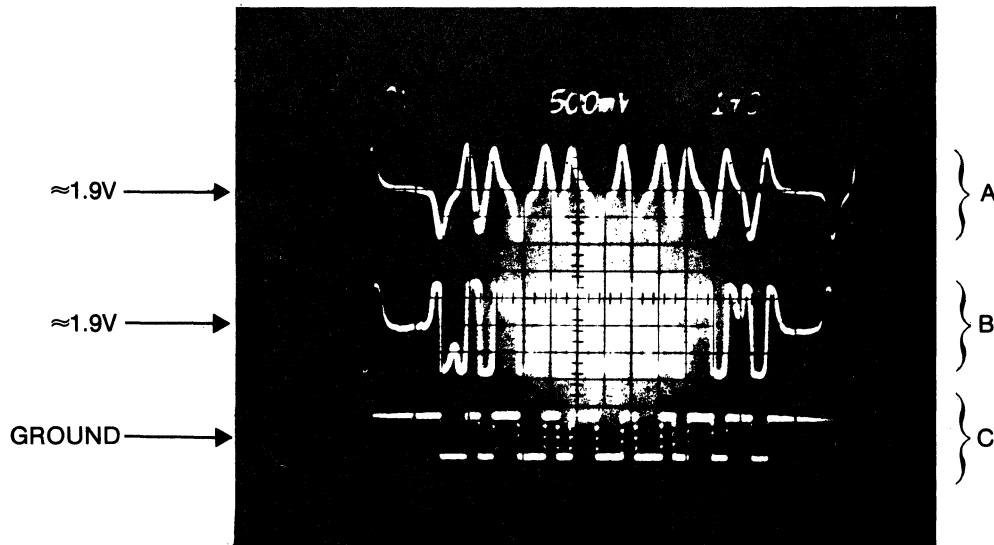

- A. OBSERVED AT U5A-1, 500 mV/div.
 B. OBSERVED AT U5D-14, 2v/div.
 C. OBSERVED AT U5C-8, 5V/div.

NOTE: STORAGE OSCILLOSCOPE USED TO OBTAIN STABLE DISPLAY.

Figure 4-10. Read Test Waveforms

6. Verify that U1-38 is logic low with a cassette installed that has the file protect tab not removed, and logic high if the tab is removed.

4-92. MAGNETIC TAPE WRITE TEST

4-93. Initiate the write test by momentarily jumpering pins 20 (ground) and 23 (WTTST) of microcomputer U1. The write test causes the controller to perform the following functions:

- Rewind the tape.
- Operate the tape drive in the forward direction and write the hexadecimal word CA at all locations on the tape.
- Rewinds at end-of-tape and repeats the write operation.

4-94. During performance of the write test, verify that the Head signal at A4J2-3 and the Head-signal at A4J2-4 appear as shown in Figure 4-11. If the signals are not as shown, check gates U3-A, B, and D; transistors Q2, Q3, and Q4; and associated resistors.

NOTE

If the read and write test fail to isolate and correct a fault that causes failure of self test, it is possible that the controller passes self test but does not communicate properly with the main microprocessor.

4-95. MAGNETIC TAPE COMMUNICATION CHECKS

4-96. Communications between the microprocessor, via the address and data bus, can be checked by means of a tester 9010A connected as described for Bus/RAM/ROM Checks. Using the tester 9010A, check communication by performing the following operations:

1. Disable the watchdog timer U31 by jumpering the C16 side of or R14 (located on the main assembly) to TP12 (ground).
2. Remove any tape cassette and leave the door open.

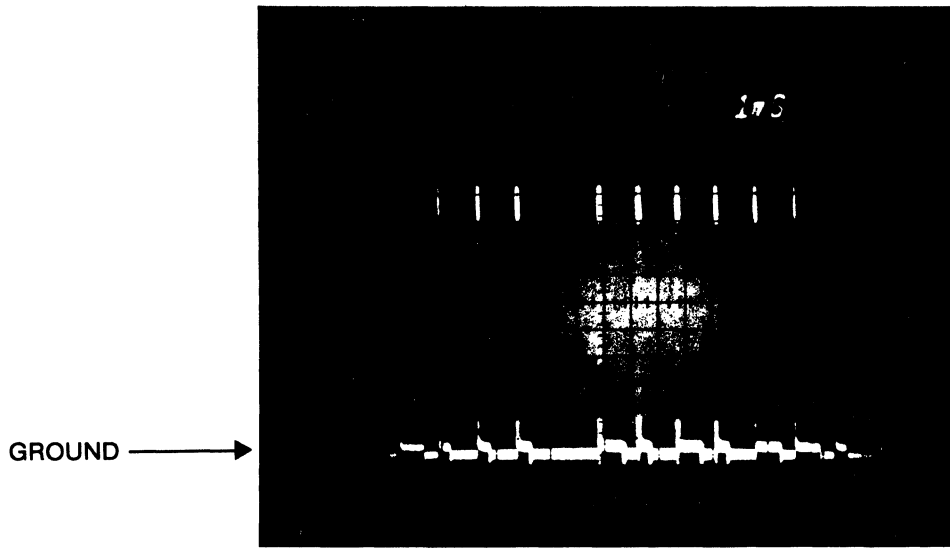

OBSERVED AT A4J2-3 (HEAD +)

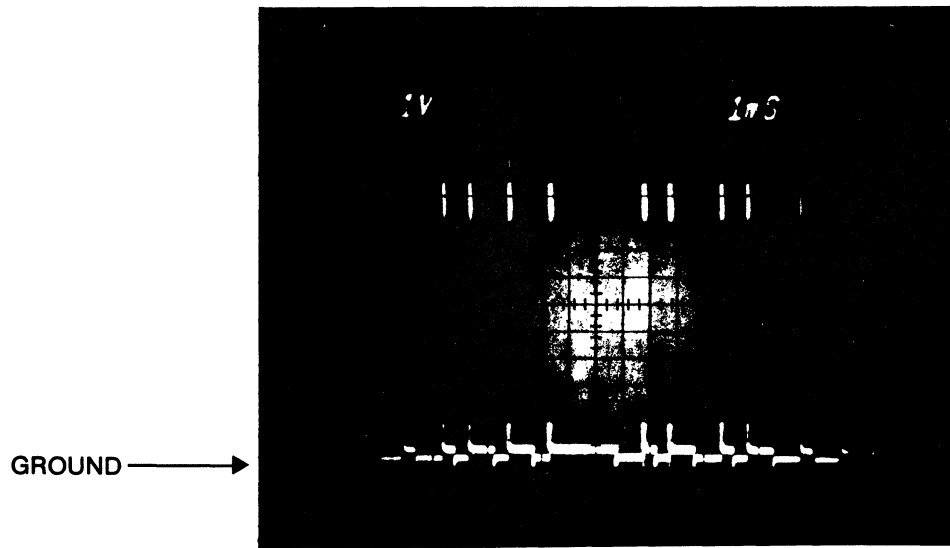

OBSERVED AT A4J2-4 (HEAD -)

NOTE: STORAGE OSCILLOSCOPE USED TO OBTAIN STABLE DISPLAY.

Figure 4-11. Write Test Waveform

3. Turn UUT power off then on. Perform a looping read at location 100A1. The data read should be 14. Reach inside the tape deck cover press the cassette-present switch located at the right of the head at the rear of the unit. The data read should be 10. Press the write protect switch located at the front of the unit and verify data read is 04.

3. Install a blank cassette (or one with obsolete data), which is not write protected, into the tape drive with the full reel to the left. Write a 11 to location 100A1. This write causes the tape to rewind and then move forward stop, rewind, go forward slightly and stop.

4. Read at location 100A1 and verify data is 48.

5. If these tests fail, perform the following series of manual tests:

a. With the tester 9010A probe in the free-run mode, verify that U1-4, 5, 26, and 40 are at logic high; U1-7 and 20 are at logic low; and that U1-2 alternates between high and low.

b. With the tester 9010A probe synchronized to address, verify that U1-8 (\overline{RD}) goes low when a read at location 100A0 is performed.

c. With the tester 9010A probe in the free-run mode, verify that U1-10 (\overline{WR}) goes low as a write at location 100A0 is repeated.

d. With the tester 9010A probe synchronized to address, verify that U1-9 (A0) toggles when a toggle address at location 100A0, bit 0 is performed.

e. With the tester 9010A probe synchronized to address, verify that U1-12 (D0) toggles as a toggle data at location 100A0, bit 0 is repeated. Repeat at pins 13 through 19 for bits 1 through 7 of location 100A0.

f. If the above tests do not locate a faulty line of the microcomputer, replace U1 with a known-good device and recheck operation of the controller.

Table 4-13. Memory and I/O Device Addressing and Commands

MEMORY PAGE ADDRESSES			
MEMORY PAGE	ADDRESS	TYPE	REFERENCE DESIGNATOR
0	0000 - 1FFF	ROM	U1*
1	2000 - 3FFF	ROM	U18
2	4000 - 5FFF	ROM	U19
3	6000 - 7FFF	ROM	U20
4	8000 - 9FFF	ROM	U21
5	A000 - BFFF	ROM	U2*
6,7	C000 - FFFF	RAM	U9-U13

*Located on piggy-back ROM pcb

DISPLAY/KEYBOARD ASSEMBLY PROTOCOL			
ADDRESS	DATA	WRITE/READ	FUNCTION PERFORMED
10080	Any	Both	Used to write and read data between the main microprocessor and the display peripheral microcomputer. On a write, sends data to the current display character. On a read, gates keyboard data. (After a write, the position pointer is incremented by one to enable the next digit to the right on the display.)
10081	FF(hex)	Write	Master reset
10081	C0(hex)	Write	Clears the 32-character display.
10081	80(hex)	Write	Turns off flashing character mode.
10081	110xxxxx (binary)	Write	Turns off the display for xxxxx scans of the display, where xxxxx is the binary number of display scans; e.g. 00001 = one scan, 1000 = 16 scans, 11111 = 31 scans.

Table 4-13. Memory and I/O Device Addressing and Commands (cont)

DISPLAY/KEYBOARD ASSEMBLY PROTOCOL (CONT)			
ADDRESS	DATA	WRITE/READ	FUNCTION PERFORMED
10081	011bbbb (binary)	Write	Sets flashing character in the display position represented by bbbbb, where bbbbb is a binary number; 00000 = leftmost position, 11111 = rightmost position.
10081	010bbbb (binary)	Write	Turns on annunciator LEDs as follows: bbbbb 00001 = EXECUTING 00010 = PROGRAMMING 00100 = STOPPED 01000 = LOOPING 10000 = MORE
10081	001bbbb (binary)	Write	Moves the store pointer to the display position represented by bbbbb, where bbbbb is a binary number; 00000 = leftmost position, 11111 = rightmost position (usually followed by a write at address 10080 to place data in the selected display position).
10081	01(hex)	Write	Selects display segment (self) test.
10081	01(hex)	Write	Selects digit drivers (self) test.
10081	04(hex)	Write	Selects annunciator (self) test.
10081	08(hex)	Write	Selects keyboard (self) test.
10081	00(hex)	Write	Selects reset test mode (always precedes the above self tests).
10081	bbbbbbb (binary)	Read	Causes peripheral microcomputer to respond with a bbbbbbb status byte as follows: bbbbbbb xxxxxx1 = Output buffer and display full xxxxxx1x = Input buffer from keyboard full xxx1xxx = Last write was control xxx0xxx = Last write was data 1xxxxxx = Overrun error (more than one key pressed before data read)
POD/PROBE PIA (U22) INTERNAL REGISTER/BUFFER ADDRESSES			
ADDRESS	WRITE DATA	REGISTER/BUFFER ADDRESSED AND FUNCTION	
100C1	00	Sets I/O Port A control register to allow addressing of I/O Port A data direction register.	
100C1	04	Sets I/O Port A control register to allow addressing if I/O Port A data buffer.	
100C0	As Required	Sets the I/O Port A data direction register in accordance with the write data, or addresses the I/O Port A data buffer; depending upon the previous setting of the I/O Port A control register.	
100C3	00	Sets I/O Port B control register to allow addressing of I/O port B data direction register.	
100C3	04	Sets I/O Port B control register to allow addressing if I/O Port B data buffer.	
100C2	As Required	Sets the I/O Port A data direction register in accordance with the write data, or addresses the I/O Port A data buffer; depending upon the previous setting of the I/O Port A control register.	

Table 4-13. Memory and I/O Device Addressing and Commands (cont)

POD/PROBE PIA (U22) PROTOCOL			
ADDRESS	DATA	WRITE/READ	FUNCTION PERFORMED
100C1	00(hex)	Write	Refer to above table of addresses.
100C1	04(hex)	Write	Refer to above table of addresses.
100C3	00(hex)	Write	Refer to above table of addresses.
100C3	04(hex)	Write	Refer to above table of addresses.
100C0	99(hex)	Write	Sets I/O port A data direction register so that all I/O port A data buffer lines are outputs (follows a WRITE @ 100C1 = 00).
100C0	FF(hex)	Write	Sets I/O port A data direction register so that all I/O port A data buffer lines are inputs (follows a WRITE @ 100C1 = 00).
100C2	00(hex)	Write	Sets I/O port B data direction register so that all I/O port B data buffer lines are outputs (follows a WRITE @ 100C3 = 00).
100C2	FF(hex)	Write	Sets I/O port B data direction register so that all I/O port B data buffer lines are inputs (follows a WRITE @ 100C3 = 00).
100C3	30(hex)	Write	Sets PIA output CB2 to off.
100C3	38(hex)	Write	Sets PIA output CB2 to on.
100C0	bbbbbbbb (binary)	Write	Performs the following functions in accordance with the binary data represented by the bbbbbbbb write data as follows (Port A must be set to output). bbbbbbbb xxxxxx1 = Set MAINSTAT output high xxxxxx0 = Set MAINSTAT output low xxxx1xxx = Set pod RESET output high xxxx0xxx = Set pod RESET output low xxx1xxxx = Activate beeper x00xxxxx = Turn probe pulse circuit off x01xxxxx = Generate low probe pulses x10xxxxx = Generate high probe pulses x11xxxxx = Generate low and high probe pulses (toggle) 0xxxxxxx = Select synchronized probe mode 1xxxxxxx = Select free-running probe mode
100C0	bbbbbbbb (binary)	Read	Causes the display peripheral microcomputer to respond with a bbbbbbbb status byte as follows (Port A must be set to input): bbbbbbbb xxxxxx1x = High PODSTAT signal from pod (see interface pod manual) xxxxxx0x = Low PODSTAT signal from pod (see interface pod manual) xxxxx1xx = High POWER FAIL signal from pod (indicates failure) xxxxx1xx = Invalid signal detected during last READ PROBE operation x1xxxxxx = Logic low signal detected during last READ PROBE operation 1xxxxxxx = Logic high signal detected during last READ PROBE operation

Table 4-13. Memory and I/O Device Addressing and Commands (cont)

MAGNETIC TAPE CONTROLLER PROTOCOL			
ADDRESS	DATA	WRITE/READ	FUNCTION
100A0	Any	Both	Used to write and read data between the main microprocessor and the magnetic tape peripheral microcomputer.
100A1	11(hex)	Write	Selects magnetic tape write mode; rewinds tape then starts in forward direction.
100A1	12(hex)	Write	Selects magnetic tape read mode; rewinds tape then starts in forward direction.
100A1	13(hex)	Write	Causes magnetic tape to stop.
100A1	bbbbbbbb (binary)	Read	Causes the magnetic tape peripheral microcomputer to respond with a bbbbbbbb status byte as follows: bbbbbbbb xxxxxx1 = Output buffer full xxxxxx1x = Input buffer full xxxxx1xx = No cassette loaded xxx1xxx = Last write was a command xxx1xxxx = Cassette write protected xx1xxxxx = End-of-tape/clear leader x1xxxxxx = Error 1xxxxxxx = End-of-file read
SIGNATURE GENERATOR/EVENT COUNTER PROTOCOL			
ADDRESS	DATA	WRITE/READ	FUNCTION PERFORMED
10000	bbbbbbbb	Read	Reads the contents of the event counter plus the probe fuse blown bit.
10020	Any	Write	Resets the signature generator and the event counter.
10040	bbbbbbbb	Read	Reads the low byte of the signature generator.
10060	bbbbbbbb	Read	Reads the high byte of the signature generator.

Section 5

List of Replaceable Parts

TABLE OF CONTENTS

ASSEMBLY NAME	TABLE		FIGURE	
	NO.	PAGE	NO.	PAGE
Final Assembly	5-1	5-3	5-1	5-5
A1 Main PCB Assembly	5-2	5-9	5-2	5-15
A2 Display PCB Assembly	5-3	5-16	5-3	5-18
A3 Keyboard Assembly	5-4	5-19	5-4	5-21
A4 Magnetic Tape PCB Assembly	5-5	5-22	5-5	5-24
A7 Data Probe PCB Assembly	5-6	5-25	5-6	5-26
A10 Piggyback ROM PCB Assembly	5-7	5-27	5-7	5-27

5-1. INTRODUCTION

5-2. This section contains an illustrated parts breakdown of the instrument. A similar parts list is included in the Options and Accessories Section for each of the options. Components are listed alphanumerically by assembly. Both electrical and mechanical components are listed by reference designation. Each listed part is shown in an accompanying illustration.

5-3. Parts lists include the following information:

1. Reference Designation.
2. Description of Each Part.
3. FLUKE Stock Number.
4. Federal Supply Code for Manufacturers.
5. Manufacturer's Part Number.
6. Total Quantity of Components Per Assembly.
7. Recommended quantity: This entry indicates the recommended number of spare parts necessary to support one to five instruments for a period of 2 years. This list presumes an availability of common electronic parts at the maintenance site. For maintenance for 1 year or more at an isolated site, it is recommended that at least one of each assembly in the instrument be stocked. In the case of optional subassemblies, plug-ins, etc., that are not always part of the instrument or are deviations from the basic instrument model, the REC QTY column lists the recommended spares quantity for the items in that particular assembly.

5-4. HOW TO OBTAIN PARTS

5-5. Components may be ordered directly from the manufacturer's part number, or from the John Fluke

Mfg. Co., Inc. or an authorized representative by using the FLUKE STOCK NUMBER. In the event the part ordered has been replaced by a new or improved part, the replacement will be accompanied by an explanatory note and installation instructions if necessary.

5-6. To ensure prompt and efficient handling of your order, include the following information.

1. Quantity.
2. FLUKE Stock Number.
3. Description.
4. Reference Designation.
5. Printed Circuit Board Part Number and Revision Letter.
6. Instrument Model and Serial Number.

5-7. A Recommended Spare Parts Kit for your basic instrument is available from the factory. This kit contains those items listed in the REC QTY column for the parts lists in the quantities recommended.

5-8. Parts price information is available from the John Fluke Mfg. Co., Inc. or its representative. Prices are also available in a Fluke Replacement Parts Catalog, which is available upon request.

CAUTION

Indicated devices are subject to damage by static discharge.

Table 5-1. Final Assembly

REF DES	DESCRIPTION	FLUKE STOCK NO.	MFG SPLY CODE	MFG PART NO.	TOT QTY	REC QTY	NOTE
	FINAL ASSEMBLY, 9010A FIGURE 5-1 (9010A-5031)						
A1⊗	MAIN PCB ASSEMBLY	579268	89536	579268	1		
A2⊗	DISPLAY PCB ASSEMBLY	579250	89536	579250	1		
A3	KEYBOARD PCB ASSEMBLY	579425	89536	579425	1		
A4⊗	MAGNETIC TAPE PCB ASSEMBLY	579441	89536	579441	1		
A7	PROBE ASSEMBLY	580969	89536	580969	1		
A10⊗	PIGGYBACK ROM PCB ASSEMBLY	613869	89536	613869	1		1
F1	FUSE 1A (100/120V)	ORDER 369819	FOR 71400	APPROPRIATE SOURCE AGC1	1		5
	1/2A (220/240V)	153858	71400	AGC1-2			
F2	FUSE, (W/XF2, MP15)	ORDER 109314	FOR 71400	APPROPRIATE SOURCE AGC1-4	1		5
	1/4A (100/120V)						
	1/4A (220/240V)	543504	75915	212.250			
H1	NUT, HEX, 6-32	110551	89536	110551	1		
H2	NUT, KEP, #4	195255	89536	195255	2		
H3	NUT, KEP, #6	152819	89536	152819	2		
H4	NUT, KEP, #8	195263	89536	195263	3		
H5	NUT, CLIP	603613	89536	603613	2		
H6	SCREW, PHP, 4-40 X 1/2	152132	89536	152132	4		
H7	SCREW, PHP, 4-40 X 3/4	115063	89536	115063	4		
H8	SCREW, PHP, 4-40 X 3/8	256164	89536	256164	1		
H9	SCREW, PHP, 4-40 X 1 3/8	614511	89536	614511	4		
H10	SCREW, PHP, 6-32 X 1/4	177022	89536	177022	6		
H11	SCREW, PHP, 6-32 X 3/8	334458	89536	334458	9		
H12	SCREW, PHP, 8-32 X 1/2	159749	89536	159749	3		
H13	SCREW, RHP, 4-40 X 1/4	256156	89536	256156	3		
H14	SCREW, RHP, 4-40 X 3/4	115063	89536	115063	2		
H15	SCREW, TRUSS HD, 6-32 X 5/16	335174	89536	335174	10		
H16	WASHER, FLAT, #4 EXT	413948	89536	413948	8		
H17	WASHER, FLAT, #6	110270	89536	110270	3		
H18	WASHER, FLAT, #8	110288	89536	110288	3		
H19	WASHER, SPLIT LOCK, #4	110395	89536	110395	2		
H20	WASHER, SPLIT LOCK, #6	169235	89536	169235	10		
MP1	BASE	583054	89536	583054	1		
MP2	BASE, SHIELD	544882	89536	544882	1		
MP3	BRACKET, FAN	607192	89536	607192	1		
MP4	BRACKET, ROM	582304	89536	582304	1		
MP5	CABLE TIE	172080	89536	172080	1		
MP6	CASE, KEYBOARD TOP	607127	89536	607127	1		
MP7	BUTTON, CASSETTE COVER	608810	89536	608810	1		
MP8	DECAL, FRONT PANEL KEYBOARD	536763	89536	536763	1		
MP9	DECAL, KEY TOP	586507	89536	586507	1		

Table 5-1. Final Assembly (cont)

REF DES	DESCRIPTION	FLUKE STOCK NO.	MFG SPLY CODE	MFG PART NO.	TOT QTY	REC QTY	N O T E
MP10	DECAL, SPEC	536839	89536	536839	1		
MP11	DOOR, CASSETTE	577676	89536	577676	1		
MP12	FAN, AIR, 12VDC	501312	89536	501312	1		
MP13	FOOT, BLACK RUBBER	513820	89536	513820	4		
MP14	FRONT PANEL, KEYBOARD	609156	89536	609156	1		
MP15	FUSEHOLDER CAP (100/120V) (220/240)	ORDER 460238 461020	FOR 89536 89536	APPROPRIATE SOURCE 460238 461020	1	1	
MP16	LINE CORD	343723	89536	343723	1		
MP17	LUG, SOLDER #6	132399	78189	2104-06-00	1		
MP18	LUG, SOLDER	441972	79963	761	1		
MP19	NAME PLATE, SERIAL # (NOT SHOWN)	472795	89536	472795	1		
MP20	NUT PLATE	609222	89536	609222	1		
MP21	NUT PLATE	609214	89536	609214	1		
MP22	POST, SLIDING LOCK ASSEMBLY	353201	89536	353201	2		
MP23	PANEL, REAR	577593	89536	577593	1		
MP24	PROBE ACCESSORIES (NOT SHOWN)	613802	89536	613802	1		
MP25	SWITCH ASSEMBLY	577619	89536	577619	1		
MP26	SPACER, FAN	607143	89536	607143	1		
MP27	SUB PANEL, BLANK	579334	89536	579334	1		
MP28	TAPE, CASSETTE	446997	51372	MI-50-3066	2	2	
MP29	CONNECTOR, BNC	152033	95712	30355-1	1		
MP30	CONNECTOR, LINE CORD	446328	05245	6J4	1		
MP31	CONNECTOR, 2-POS	602706	00779	640442-2	1		
T1	TRANSFORMER, POWER (ON A1 ASSEMBLY)	579185	89536	579185	1		
TM1	OPERATION MANUAL, 9010A	609263	89536	609263	1		
TM2	REFERENCE GUIDE, 9010A	609271	89536	609271	1		
TM3	PROGRAM MANUAL, 9010A	609289	89536	609289	1		
TM4	SERVICE MANUAL, 9010A	609297	89536	609297	1		
W2	CABLE, AC	581843	89536	581843	1		
W3	CABLE, POWER SWITCH	609123	89536	609123	1		
	RECOMMENDED SPARES KIT	638619	89536	638619		AR	
XF2	SEE A1, TABLE 5-2						
	1 ATTACHED TO A1 PCB WITH MP4 BRACKET						

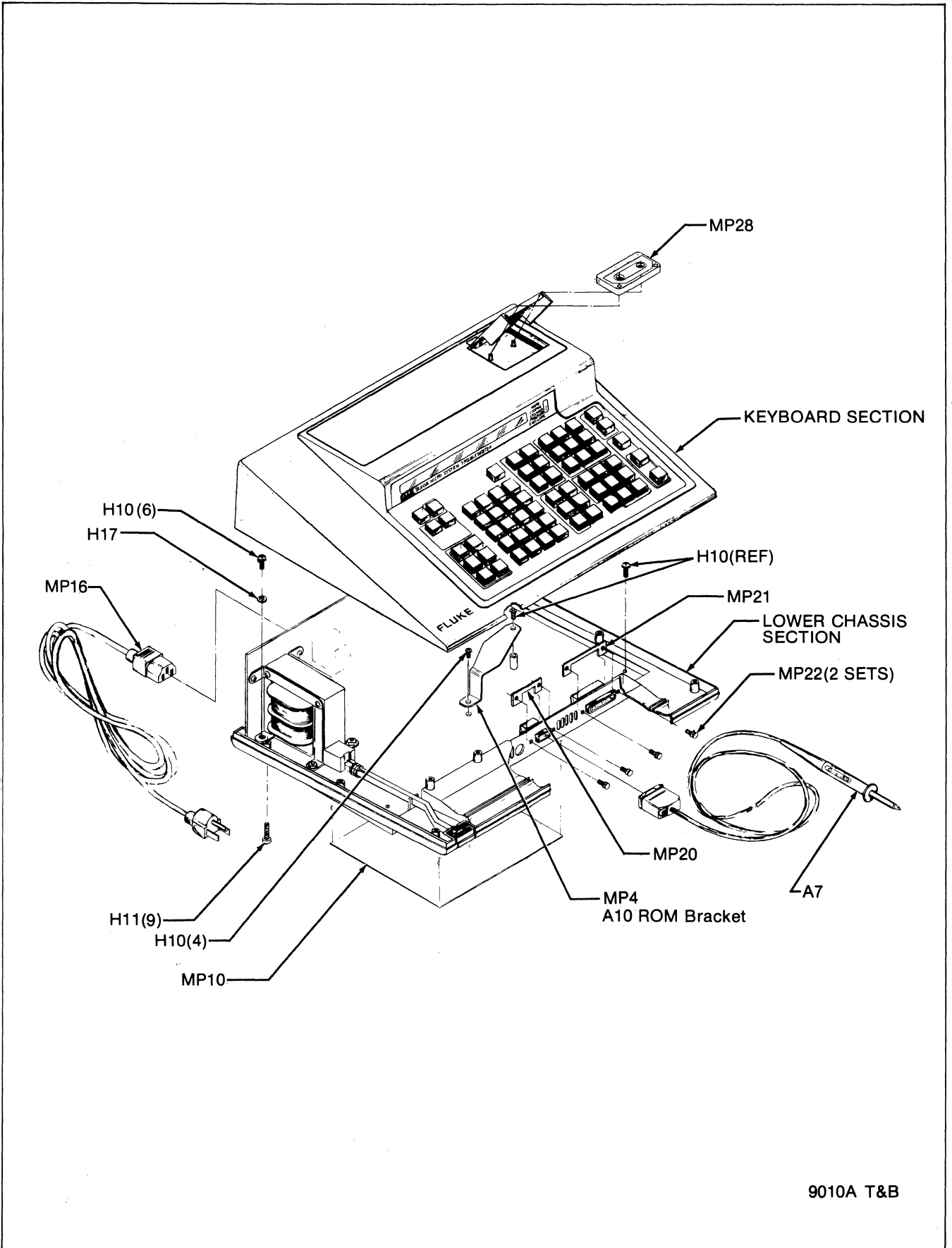

9010A T&B

Figure 5-1. Final Assembly

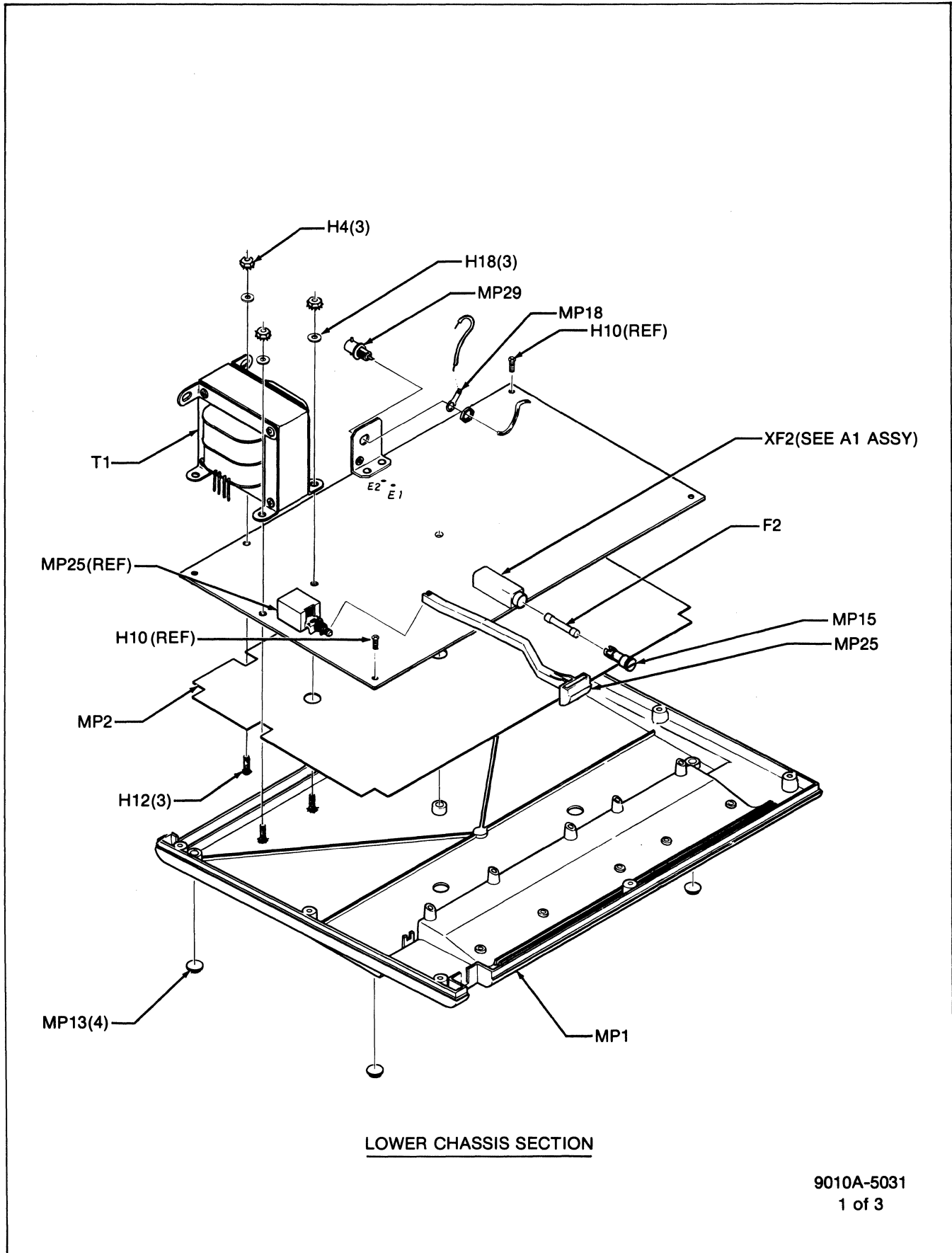

9010A-5031
1 of 3

Figure 5-1. Final Assembly (cont)

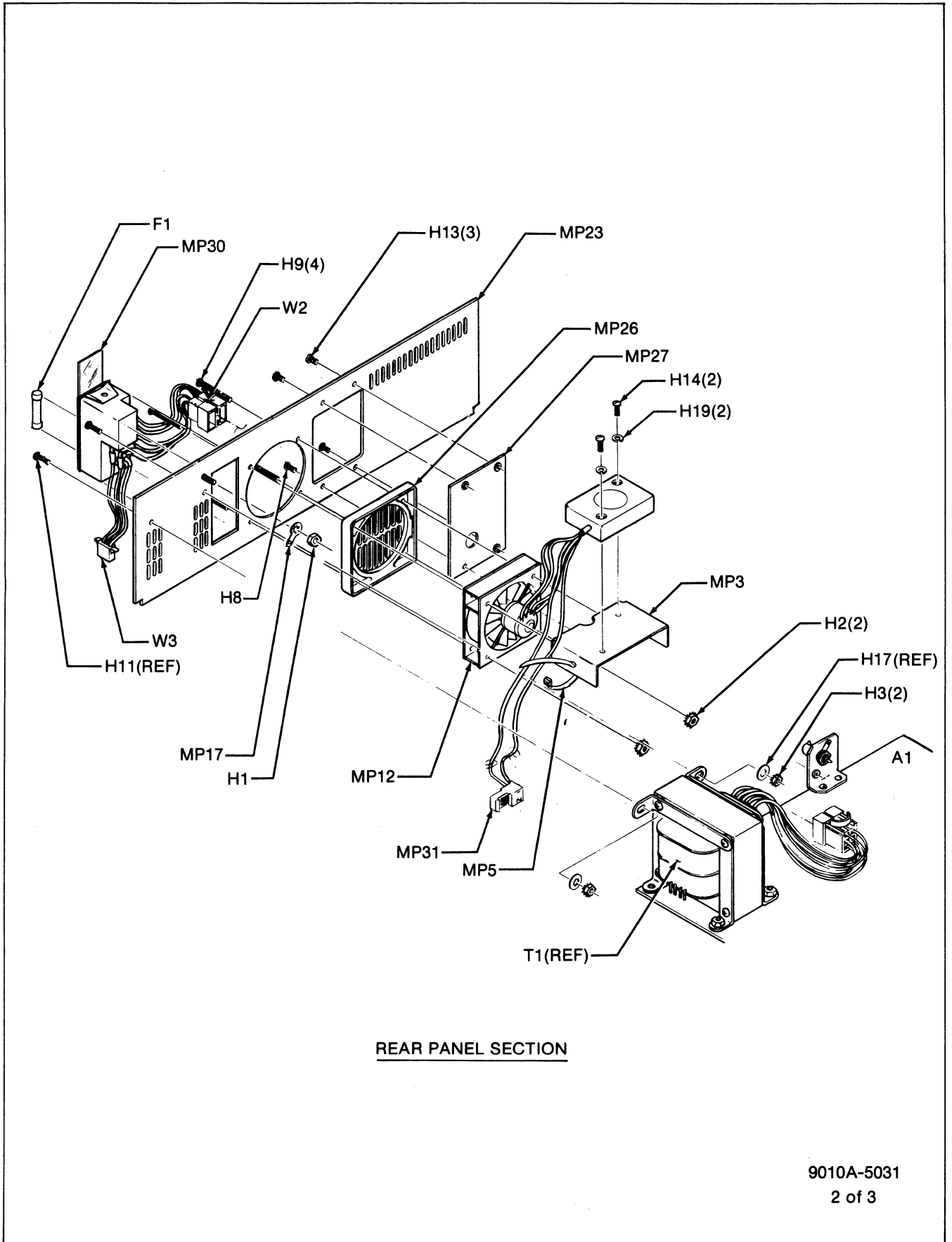

9010A-5031
2 of 3

Figure 5-1. Final Assembly (cont)

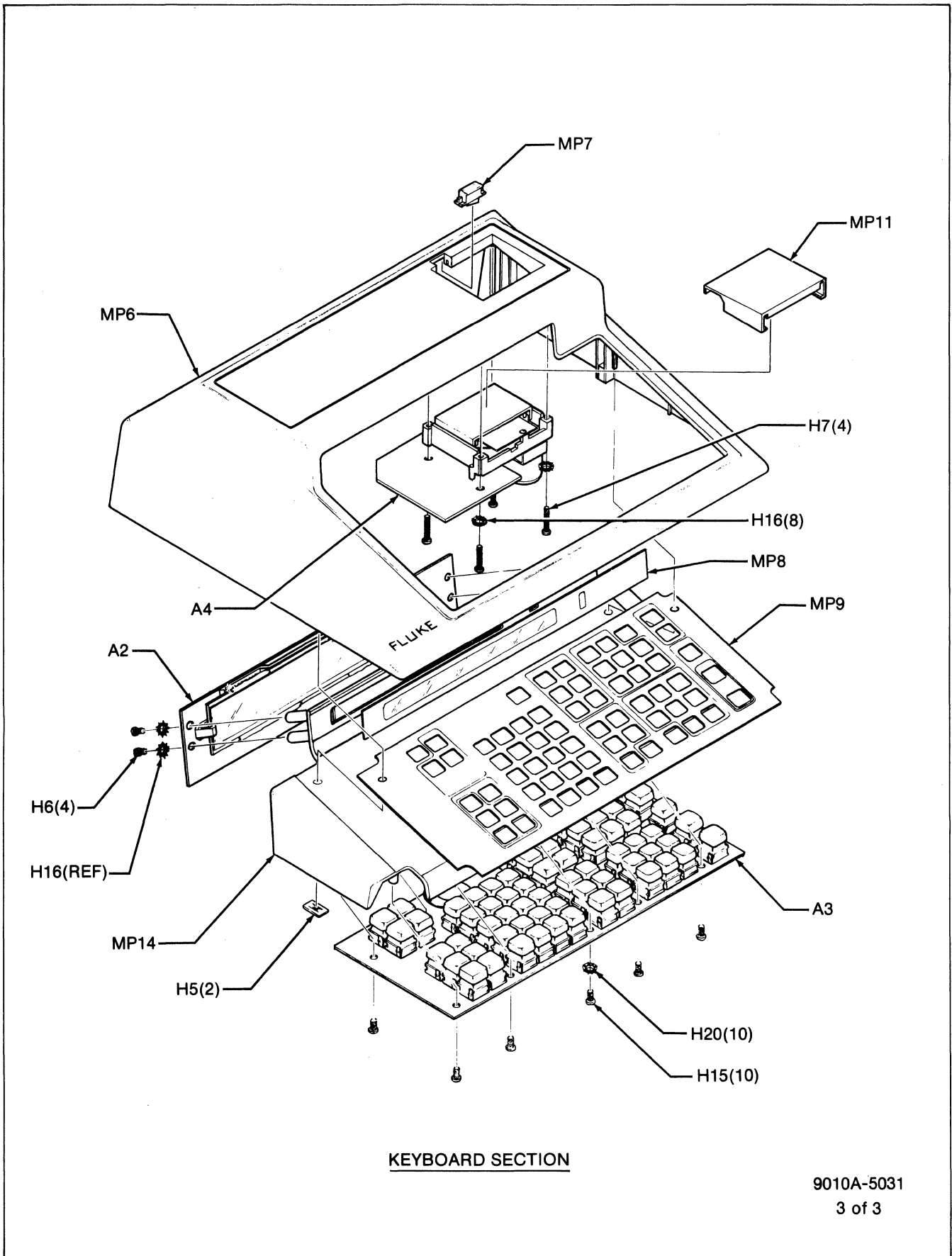

Figure 5-1. Final Assembly (cont)

Table 5-2. A1 Main PCB Assembly

REF DES	DESCRIPTION	FLUKE STOCK NO.	MFG SPLY CODE	MFG PART NO.	TOT QTY	REC QTY	NOTE
A10	MAIN PCB ASSEMBLY FIGURE 5-2 (9000A-4001T)	579300	89536	579300			REF
C1	CAP, ELECT, 15,000 UF -10/+30%, 16V	574186	89536	574186		3	
C2	CAP, ELECT, 15,000 UF -10/+30%, 16V	574186	89536	574186			REF
C3	CAP, ELECT, 15,000 UF -10/+30%, 16V	574186	89536	574186			REF
C4	CAP, ELECT, 100 UF -10/+75%, 15V	416982	89536	416982		7	
C5	CAP, ELECT, 47 UF -10/+75%, 16V	519561	89536	519561		2	
C6	CAP, ELECT, 3300 UF -10/+30%, 25V	574178	89536	574178		3	
C7	CAP, ELECT, 100 UF -10/+75%, 15V	416982	89536	416982			REF
C8	CAP, ELECT, 47 UF -10/+75%, 16V	519561	89536	519561			REF
C9	CAP, ELECT, 3300 UF -10/+30%, 25V	574178	89536	574178			REF
C10	CAP, ELECT, 100 UF -10/+75%, 15V	416982	89536	416982			REF
C11	CAP, ELECT, 100 UF -10/+75%, 15V	416982	89536	416982			REF
C12	CAP, ELECT, 3300 UF -10/+30%, 25V	574178	89536	574178			REF
C13	CAP, ELECT, 470 UF 80/100V	574160	89536	574160		1	
C16	CAP, TA, 10 UF +/-20%, 20V	330662	56289	196D106X0020KA1		2	
C17	CAP, CER, 0.1 UF, GMV, 10V	368647	71590	UK10-104		2	
C18	CAP, CER, 0.22 UF +/-20%, 50V	519157	51406	RPE111Z5U224M50V		41	
C19	CAP, CER, 0.22 UF +/-20%, 50V	519157	51406	RPE111Z5U224M50V			REF
C20	CAP, CER, 0.22 UF +/-20%, 50V	519157	51406	RPE111Z5U224M50V			REF
C21	CAP, CER, 0.22 UF +/-20%, 50V	519157	51406	RPE111Z5U224M50V			REF
C22	CAP, CER, 0.22 UF +/-20%, 50V	519157	51406	RPE111Z5U224M50V			REF
C23	CAP, CER, 0.22 UF +/-20%, 50V	519157	51406	RPE111Z5U224M50V			REF
C24	CAP, CER, 0.22 UF +/-20%, 50V	519157	51406	RPE111Z5U224M50V			REF
C25	CAP, CER, 0.22 UF +/-20%, 50V	519157	51406	RPE111Z5U224M50V			REF
C26	CAP, CER, 0.22 UF +/-20%, 50V	519157	51406	RPE111Z5U224M50V			REF
C27	CAP, CER, 0.22 UF +/-20%, 50V	519157	51406	RPE111Z5U224M50V			REF
C28	CAP, CER, 0.22 UF +/-20%, 50V	519157	51406	RPE111Z5U224M50V			REF
C29	CAP, CER, 0.22 UF +/-20%, 50V	519157	51406	RPE111Z5U224M50V			REF
C30	CAP, CER, 0.22 UF +/-20%, 50V	519157	51406	RPE111Z5U224M50V			REF
C31	CAP, CER, 0.22 UF +/-20%, 50V	519157	51406	RPE111Z5U224M50V			REF
C32	CAP, CER, 0.22 UF +/-20%, 50V	519157	51406	RPE111Z5U224M50V			REF
C33	CAP, CER, 0.22 UF +/-20%, 50V	519157	51406	RPE111Z5U224M50V			REF
C34	CAP, CER, 0.22 UF +/-20%, 50V	519157	51406	RPE111Z5U224M50V			REF
C35	CAP, CER, 0.22 UF +/-20%, 50V	519157	51406	RPE111Z5U224M50V			REF
C36	CAP, CER, 0.22 UF +/-20%, 50V	519157	51406	RPE111Z5U224M50V			REF
C37	CAP, CER, 0.22 UF +/-20%, 50V	519157	51406	RPE111Z5U224M50V			REF
C38	CAP, CER, 0.22 UF +/-20%, 50V	519157	51406	RPE111Z5U224M50V			REF
C39	CAP, CER, 0.22 UF +/-20%, 50V	519157	51406	RPE111Z5U224M50V			REF
C40	CAP, CER, 0.22 UF +/-20%, 50V	519157	51406	RPE111Z5U224M50V			REF
C41	CAP, CER, 0.22 UF +/-20%, 50V	519157	51406	RPE111Z5U224M50V			REF
C43	CAP, CER, 0.22 UF +/-20%, 50V	519157	51406	RPE111Z5U224M50V			REF
C44	CAP, ELECT, 100 UF -10/+75%, 15V	416982	89536	416982			REF
C45	CAP, CER, 0.22 UF +/-20%, 50V	519157	51406	RPE111Z5U224M50V			REF
C47	CAP, CER, 0.22 UF +/-20%, 50V	519157	51406	RPE111Z5U224M50V			REF
C48	CAP, CER, 0.01 UF +/-5%, 16V	368639	14655	HCC16103P		1	
C49	CAP, CER, 0.1 UF, GMV, 10V	368647	71590	UK10-104			REF
C50	CAP, CER, 0.22 UF +/-20%, 50V	519157	51406	RPE111Z5U224M50V			REF
C51	CAP, VAR, 1.7 - 10 PF, 250V	321109	56289	GKB10000		1	

Table 5-2. A1 Main PCB Assembly (cont)

REF DES	DESCRIPTION	FLUKE STOCK NO.	MFG SPLY CODE	MFG PART NO.	TOT QTY	REC QTY	N O T E
C52	CAP, VAR, 4.5 - 50 PF, 250V	321117	73899	DVJ305A	1		
C53	CAP, CER, 0.22 UF +/-20%, 50V	519157	51406	RPE111Z5U224M50V	REF		
C54	CAP, CER, 0.001 UF +/-20%, 500V	402966	72982	8121-A100-W5R-102M	3		
C55	CAP, CER, 0.001 UF +/-20%, 500V	402966	72982	8121-A100-W5R-102M	REF		
C56	CAP, TA, 22 UF +/-20%, 15V	423012	56289	196D226X0015KA1	4		
C57	CAP, CER, 0.22 UF +/-20%, 50V	519157	51406	RPE111Z5U224M50V	REF		
C58	CAP, CER, 0.22 UF +/-20%, 50V	519157	51406	RPE111Z5U224M50V	REF		
C59	CAP, CER, 0.22 UF +/-20%, 50V	519157	51406	RPE111Z5U224M50V	REF		
C60	CAP, CER, 0.22 UF +/-20%, 50V	519157	51406	RPE111Z5U224M50V	REF		
C61	CAP, CER, 0.22 UF +/-20%, 50V	519157	51406	RPE111Z5U224M50V	REF		
C62	CAP, CER, 0.22 UF +/-20%, 50V	519157	51406	RPE111Z5U224M50V	REF		
C64	CAP, CER, 100 PF +/-10%, 1000V	105593	71590	DD-101	2		
C65	CAP, CER, 2000 PF, GMV, 1000V	105569	71590	DA140-139CB	1		
C66	CAP, TA, 22 UF +/-20%, 15V	423012	56289	196D226X0015KA1	REF		
C67	CAP, TA, 22 UF +/-20%, 15V	423012	56289	196D226X0015KA1	REF		
C68	CAP, TA, 10 UF +/-20%, 20V	330662	56289	196D106X0020KA1	REF		
C69	CAP, TA, 22 UF +/-20%, 15V	423012	56289	196D226X0015KA1	REF		
C70	CAP, CER, 100 PF +/-10%, 1000V	105593	71590	DD-101	REF		
C71	CAP, CER, 0.22 UF +/-20%, 50V	519157	51406	RPE111Z5U224M50V	REF		
C72	CAP, CER, 0.22 UF +/-20%, 50V	519157	51406	RPE111Z5U224M50V	REF		
C76	CAP, ELECT, 100 UF -10/+75%, 15V	416982	89536	416982	REF		
C77	CAP, ELECT, 100 UF -10/+75%, 15V	416982	89536	416982	REF		
C78	CAP, TA, 6.8 UF +/-20%, 35V	363713	56289	196D685X0035KA1	2		
C79	CAP, TA, 6.8 UF +/-20%, 35V	363713	56289	196D685X0035KA1	REF		
C80	CAP, CER, 0.001 UF +/-20%, 500V	402966	72982	8121-A100-W5R-102M	REF		
C81	CAP, CER, 0.22 UF +/-20%, 50V	519157	51406	RPE111Z5U224M50V	REF		
C82	CAP, CER, 470 PF +/-20%, 100V	358275	72982	8111-A100-W5R-471M	3		
C83	CAP, CER, 470 PF +/-20%, 100V	358275	72982	8111-A100-W5R-471M	REF		
C84	CAP, CER, 470 PF +/-20%, 100V	358275	72982	8111-A100-W5R-471M	REF		
C85	CAP, CER, 500 PF +/-110%, 1KV	105692	71590	2DDH60N501K	1		
C86	CAP, CER, 0.22 UF +/-20%, 50V	519157	51406	RPE111Z5U224M50V	REF		
C87	CAP, CER, 0.22 UF +/-20%, 50V	519157	51406	RPE111Z5U224M50V	REF		
C88	CAP, CER, 0.22 UF +/-20%, 50V	519157	51406	RPE111Z5U224M50V	REF		
CR1	DIODE, SI, HIGH VOLTAGE	325746	04713	MR751	2	1	
CR2	DIODE, SI, HIGH VOLTAGE	325746	04713	MR751	REF		
CR3	DIODE, HI-SPEED SWITCHING	203323	07910	1N4448	9	2	
CR4	DIODE, HI-SPEED SWITCHING	203323	07910	1N4448	REF		
CR5	DIODE, HI-SPEED SWITCHING	203323	07910	1N4448	REF		
CR6	DIODE, HI-SPEED SWITCHING	203323	07910	1N4448	REF		
CR7	DIODE, HI-SPEED SWITCHING	203323	07910	1N4448	REF		
CR10	DIODE, HI-SPEED SWITCHING	203323	07910	1N4448	REF		
CR11	DIODE, HI-SPEED SWITCHING	203323	07910	1N4448	REF		
CR12	DIODE, HI-SPEED SWITCHING	203323	07910	1N4448	REF		
CR13	DIODE, HI-SPEED SWITCHING	203323	07910	1N4448	REF		
E3	CONNECTOR, POST	267500	00779	86144-2	REF		
G1	CRYSTAL, OSCILLATOR, 6.5 MHZ, +/-1%	586933	89536	586610	1	1	
H1	NUT, HEX, 4-40	147611	89536	147611	3		
H2	NUT, HEX, LOCKING, 6-32	329722	89536	329722	2		
H3	SCREW, RHP, 4-40 X 1/4	256156	89536	256156	3		
H4	SCREW, PHP, 6-32 X 5/16	424713	89536	424713	2		

Table 5-2. A1 Main PCB Assembly (cont)

REF DES	DESCRIPTION	FLUKE STOCK NO.	MFG SPLY CODE	MFG PART NO.	TOT QTY	REC QTY	NOTE
H5	WASHER, SPLIT LOCK, #4	110395	89536	110395	3		
H6	WASHER, SPLIT LOCK, #6	110692	89536	110692	2		
J1	CONNECTOR	461996	00779	206584-1	1		
J2	CONNECTOR, 9 CONTACT	574541	00779	207084-2	1		
J3	CONNECTOR, POST	267500	00779	86144-2	85		
J4	CONNECTOR, POST	267500	00779	86144-2		REF	
J5	CONNECTOR PIN	513879	00779	4-870221	26		
J8	CONNECTOR, POST	267500	00779	86144-2		REF	
J9	SOCKET, 28-PIN	419077	01295	C-922800	1		
L1	CHOKE, 10 UH	502138	89536	502138	1		
MP1	BRACKET, BNC	577635	89536	577635	1		
MP2	COVER, AC SWITCH	475681	89536	475681	1		
MP3	HEAT SINK	536797	89536	536797	1		
MP4	HEAT SINK	524934	13103	6025B-TT	3		
MP5	SPACER, STANDOFF	416750	89536	416750	1		
MP6	SPACER, FOR 14 PIN DIP	441865	32559	814-060	1		
MP7	SPACER, STANDOFF	435578	89536	435578	4		
P6	CONNECTOR, 2-PIN	602698	00779	640456-1	1		
P7	CONNECTOR, PCB HEADER	512269	00779	350211-1	1		
P8	CONNECTOR, POST	267500	00779	86144-2		REF	
Q1	TRANSISTOR, FIELD EFFECT	288910	17856	DN1807	1		1
Q2	TRANSISTOR, SI, NPN	218396	04713	2N3904	1		1
Q3	TRANSISTOR, SI, NPN	330803	04713	MPS6560	4		1
Q4	TRANSISTOR, SI, NPN	330803	04713	MPS6560		REF	
Q5	TRANSISTOR, SI, NPN	330803	04713	MPS6560		REF	
Q6	TRANSISTOR, SI, NPN	330803	04713	MPS6560		REF	
R1	RES, COMP, 750 +/-5%, 1/2W	108894	01121	EB7515	1		
R2	RES, VAR, 100 +/-10%, 1/2W	275735	11236	360T-101A	1		
R3	RES, DEP. CAR, 300 +/-5%, 1/4W	441519	80031	CR251-4-5P300E	1		
R4	RES, DEP. CAR, 120 +/-5%, 1/4W	442293	80031	CR251-4-5P120E	1		
R5	RES, DEP. CAR, 1.5K +/-5%, 1/4W	573212	80031	CR251-4-5P1K5	1		
R6	RES, COMP, 2.7K +/-5%, 1/2W	109074	01121	EB2725	1		
R7	RES, COMP, 1.5K +/-5%, 1/2W	266353	01121	EB1K35	1		
R8	RES, COMP, 18K +/-5%, 1/2W	187898	01121	EB1845	1		
R10	RES, COMP, 100 +/-5%, 1/2W	188508	01121	EB1015	1		
R12	RES, DEP. CAR, 20 +/-5%, 1/4W	572958	80031	CR251-4-5P20E	2		
R13	RES, DEP. CAR, 20 +/-5%, 1/4W	572958	80031	CR251-4-5P20E		REF	
R14	RES, DEP. CAR, 1M +/-5%, 1/4W	573691	80031	CR251-4-5P1M	1		
R15	RES, DEP. CAR, 100K +/-5%, 1/4W	573584	80031	CR251-4-5P100K	3		
R16	RES, DEP. CAR, 100K +/-5%, 1/4W	573584	80031	CR251-4-5P100K		REF	
R17	RES, DEP. CAR, 220K +/-5%, 1/4W	573642	80031	CR251-4-5P220K	1		
R18	RES, DEP. CAR, 4.7K +/-5%, 1/4W	573311	80031	CR251-4-5P4K7	2		
R19	RES, DEP. CAR, 4.7K +/-5%, 1/4W	573311	80031	CR251-4-5P4K7		REF	
R20	RES, DEP. CAR, 10K +/-5%, 1/4W	573394	80031	CR251-4-5P10K	2		
R21	RES, DEP. CAR, 2K +/-5%, 1/4W	573238	80031	CR251-4-5P2K	1		
R22	RES, DEP. CAR, 220 +/-5%, 1/4W	574244	80031	CR251-4-5P220E	1		
R23	RES, DEP. CAR, 200 +/-5%, 1/4W	573055	80031	CR251-4-5P200E	2		
R24	RES, DEP. CAR, 330 +/-5%, 1/4W	573089	80031	CR251-4-5P330E	1		
R25	RES, DEP. CAR, 150 +/-5%, 1/4W	573030	80031	CR251-4-5P150E	1		
R26	RES, MEL. FILM, 15K +/-1%, 1/8W	285296	91637	CMF551502F	1		
R27	RES, MEL. FILM, 4.42K +/-1%, 1/8W	288514	91637	CMF554421F	1		

Table 5-2. A1 Main PCB Assembly (cont)

REF DES	DESCRIPTION	FLUKE STOCK NO.	MFG SPLY CODE	MFG PART NO.	TOT QTY	REC QTY	NOTE
R28	RES, MTL. FILM, 200 +/-1%, 1/8W	245340	91637	CMF552000F	1		
R29	RES, MTL. FILM, 100 +/-1%, 1/8W	168195	91637	CMF551000F	1		
R30	RES, DEP. CAR, 2.2K +/-5%, 1/4W	573246	80031	CR251-4-5P2K2	7		
R31	RES, DEP. CAR, 2.2K +/-5%, 1/4W	573246	80031	CR251-4-5P2K2	REF		
R32	RES, DEP. CAR, 2.2K +/-5%, 1/4W	573246	80031	CR251-4-5P2K2	REF		
R33	RES, DEP. CAR, 470 +/-5%, 1/4W	573121	80031	CR251-4-5P470E	REF		
R34	RES, DEP. CAR, 390 +/-5%, 1/4W	573105	80031	CR251-4-5P390E	1		
R35	RES, DEP. CAR, 100 +/-5%, 1/4W	573014	80031	CR251-4-5P100E	4		
R36	RES, DEP. CAR, 100 +/-5%, 1/4W	573014	80031	CR251-4-5P100E	REF		
R37	RES, DEP. CAR, 100 +/-5%, 1/4W	573014	80031	CR251-4-5P100E	REF		
R38	RES, DEP. CAR, 750 +/-5%, 1/4W	573162	80031	CR251-4-5P750E	1		
R39	RES, DEP. CAR, 1K +/-5%, 1/4W	573170	80031	CR251-4-5P1K	3		
R40	RES, DEP. CAR, 100K +/-5%, 1/4W	573584	80031	CR251-4-5P100K	REF		
R41	RES, DEP. CAR, 200 +/-5%, 1/4W	573055	80031	CR251-4-5P200E	REF		
R42	RES, DEP. CAR, 10K +/-5%, 1/4W	573394	80031	CR251-4-5P10K	REF		
R43	RES, DEP. CAR, 680 +/-5%, 1/4W	573154	80031	CR251-4-5P680E	1		
R46	RES, DEP. CAR, 1K +/-5%, 1/4W	573170	80031	CR251-4-5P1K	REF		
R47	RES, DEP. CAR, 2.2K +/-5%, 1/4W	573246	80031	CR251-4-5P2K2	REF		
R48	RES, DEP. CAR, 1K +/-5%, 1/4W	573170	80031	CR251-4-5P1K	REF		
R49	RES, DEP. CAR, 10K +/-5%, 1/4W	348839	80031	CR251-4-5P10K	3		
R50	RES, DEP. CAR, 2.7K +/-5%, 1/4W	573261	80031	CR251-4-5P2K7	1		
R51	RES, DEP. CAR, 5.1K +/-5%, 1/4W	573329	80031	CR251-4-5P5K1	1		
R52	RES, DEP. CAR, 100 +/-5%, 1/4W	573014	80031	CR251-4-5P100E	REF		
R53	RES, DEP. CAR, 2.2K +/-5%, 1/4W	573246	80031	CR251-4-5P2K2	REF		
R54	RES, DEP. CAR, 2.2K +/-5%, 1/4W	573246	80031	CR251-4-5P2K2	REF		
R55	RES, DEP. CAR, 10 +/-5%, 1/4W	572941	80031	CR251-4-5P10E	1		
R56	RES, DEP. CAR, 2K +/-5%, 1/4W	441469	80031	CR251-4-5P2K	1		
R57	RES, DEP. CAR, 10K +/-5%, 1/4W	348839	80031	CR251-4-5P10K	REF		
R58	RES, DEP. CAR, 10K +/-5%, 1/4W	348839	80031	CR251-4-5P10K	REF		
R59	RES, COMP, 4.7K +/-5%, 1/4W	348821	01121	CB4725	1		
R60	RES, DEP. CAR, 1K +/-5%, 1/4W	573170	80031	CR251-4-5P1K	2		
R61	RES, DEP. CAR, 1K +/-5%, 1/4W	573170	80031	CR251-4-5P1K	REF		
RV1	VARISTOR, RMS VOLT 300	443192	09214	V300LA2	1		
S1	SWITCH, ON-OFF	453605	89536	453605	1	1	
T1	SEE FINAL ASSEMBLY, TABLE 5-1						
T2	TRANSFORMER, PULSE	579219	89536	579219	1		
TP1-TP14	CONNECTOR, POST	267500	00779	86144-2	REF		
U1	IC, ADJUSTABLE VOLTAGE REGULATOR	585497	12040	LM338K	1	1	
U2	RECTIFIER, BRIDGE	296509	09423	FB200	3	1	
U3	IC, LIN, NEG VOLT, REG SERIES 2-24 VOLTS	394551	04713	MC7905CT	1	1	
U4	BRIDGE RECTIFIER	296509	09423	FB200	REF		
U5	IC, LIN, VOLT REG, FIXED VOLTAGES	413195	04713	MC7812TP	1	1	
U6	RECTIFIER, BRIDGE	296509	09423	FB200	REF		
U7	RECTIFIER, BRIDGE	341008	11711	KBPO6	1	1	
U8⊗	IC, MOS, SI, GATE N-CHANNEL, 8-BIT	478073	50088	MK3880-4CPU	1	1	
U9⊗	IC, MOS, 16,384-BIT RANDOM ACCESS MEMORY	483487	01295	TMS4116-25JL	8	2	
U10⊗	IC, MOS, 16,384-BIT RANDOM ACCESS MEMORY	483487	01295	TMS4116-25JL	REF		
U11⊗	IC, MOS, 16,384-BIT RANDOM ACCESS MEMORY	483487	01295	TMS4116-25JL	REF		
U12⊗	IC, MOS, 16,384-BIT RANDOM ACCESS MEMORY	483487	01295	TMS4116-25JL	REF		
U13⊗	IC, MOS, 16,384-BIT RANDOM ACCESS MEMORY	483487	01295	TMS4116-25JL	REF		

Table 5-2. A1 Main PCB Assembly (cont)

REF DES	DESCRIPTION	FLUKE STOCK NO.	MFG SPLY CODE	MFG PART NO.	TOT QTY	REC QTY	N O T E
U14⊙	IC, MOS, 16,384-BIT RANDOM ACCESS MEMORY	483487	01295	TMS4116-25JL	REF		
U15⊙	IC, MOS, 16,384-BIT RANDOM ACCESS MEMORY	483487	01295	TMS4116-25JL	REF		
U16⊙	IC, MOS, 16,384-BIT RANDOM ACCESS MEMORY	483487	01295	TMS4116-25JL	REF		
U18	IC, ROM	605089	89536	605089	1	1	
U19	IC, ROM	605097	89536	605097	1	1	
U20	IC, ROM	605105	89536	605105	1	1	
U21	IC, ROM	605113	89536	605113	1	1	
U22	IC, PERIPHERAL INTERFACE ADAPTER	536318	55576	SYP6520	1	1	
U23	IC, TTL, MSI, DATA SELECTOR, MULTIPLEXER	407833	01295	SN74LS157N	3	1	
U24	IC, TTL, MSI, DATA SELECTOR, MULTIPLEXER	407833	01295	SN74LS157N	REF		
U25	IC, TTL, LO-PWR, 3-8 LINE DECODER	407585	01295	SN74LS138N	2	1	
U26	IC, TTL, QUAD, 2-INPUT NOR GATE	393041	01295	SN74LS02N	2	1	
U27	IC, TTL, QUAD, 2-INPUT, POS NAND GATE	393033	01295	SN74LS00N	1	1	
U28	IC, TTL, HEX INVERTER	393058	01295	SN74LS04N	1	1	
U29	IC, TTL, DUAL J-K FLIP/FLOP	414029	01295	SN74LS112N	1	1	
U30	IC, TTL, HEX INVERTER	407593	01295	SN7406N	1	1	
U31⊙	IC, C-MOS, RE-TRIG/RESET MULTIVIBRATOR	393512	02735	CD4098AE	1	1	
U32	IC, TTL, LO-PWR, DUAL J-K, FLIP/FLOP	412999	01295	SN74LS109N	2	1	
U33	RESISTOR NETWORK	412924	89536	412924	1	1	
U34	IC, LO-PWR SCHOTTKY	393124	01295	SN74LS74N	1	1	
U35	IC, LINEAR, DUAL TIMER	387407	18324	NE556A	1	1	
U36	IC, HI-SPEED ANALOG VOL COMPARATOR	386920	18324	NE529A	2	1	
U37	IC, LO-PWR SCHOTTKY	393124	01295	SN74LS74N	1	1	
U38	IC, TTL, MSI, DATA SELECTOR, MULTIPLEXER	407833	01295	SN74LS157N	REF		
U39	IC, TTL POS NAND GATES/INVERTERS	393074	01295	SN74LS10N	1	1	
U40	IC, TTL, QUAD, 2-INPUT NOR GATE	393041	01295	SN74LS02N	REF		
U41	IC, TTL, HEX INVERTER W/TP OUTPUTS	352039	01295	SN74LS04N	1	1	
U42	IC, LO-PWR SCHOTTKY	404186	01295	SN74LS123N	3	1	
U43	IC, LO-PWR SCHOTTKY	404186	01295	SN74LS123N	REF		
U44	IC, TTL, QUAD 2-INPUT NOR BUFFER	414037	01295	SN74LS33N	1	1	
U45⊙	IC, C-MOS, QUAD D TYPE FLIP-FLOP	536292	04713	MC14175B	1	1	
U46⊙	IC, C-MOS, QUAD R-S LATCH	536607	04713	MC14043BCP	1	1	
U47	RESISTOR NETWORK	408310	89536	408310	1	1	
U48	RESISTOR NETWORK	520122	89536	520122	1	1	
U49	IC, HI-SPEED ANALOG VOL COMPARATOR	386920	18324	NE529A	REF		
U50	IC, ECL, QUAD LINE RECIEVER	584045	04713	MC10115P	1	1	
U51	IC, TTL, QUAD 2-INPUT EXCLUSIVE OR GATE	408237	01295	SN74LS86N	1	1	
U52	IC, TTL 8-BIT PARALLEL OUT SER SHIFT REG	408732	01295	SN74LS164N	2	1	
U53	IC, OCTAL BUFFERS & LINE DRIVERS	429035	01295	SN74LS244N	3	1	
U54	IC, TTL 8-BIT PARALLEL OUT SER SHIFT REG	408732	01295	SN74LS164N	REF		
U55	IC, OCTAL BUFFERS & LINE DRIVERS	429035	01295	SN74LS244N	REF		
U56	RESISTOR NETWORK	459974	89536	459974	1	1	
U57	IC, TTL, LO-PWR, DUAL J-K, FLIP/FLOP	412999	01295	SN74LS109N	REF		
U58	IC, VOLTAGE REGULATOR, 8V	407627	04713	MC7808CT	1	1	
U59	IC, DUAL 4-BIT DECADE, BINARY COUNTERS	483578	01295	SN74LS393N	1	1	
U60	IC, OCTAL BUFFERS & LINE DRIVERS	429035	01295	SN74LS244N	REF		
U61	IC, LO-PWR SCHOTTKY	404186	01295	SN74LS123N	REF		
U62	IC, ROM	605055	89536	605055	1	1	
U63	RESISTOR NETWORK	414557	89536	414557	1	1	
W1	WIRE, JUMPER	529776	89536	529776	1		

Table 5-2. A1 Main PCB Assembly (cont)

REF DES	DESCRIPTION	FLUKE STOCK NO.	MFG SPLY CODE	MFG PART NO.	TOT QTY	REC QTY	NOTE
W4	WIRE, JUMPER, #22 AWG	529701	89536	529701	2		
W6	WIRE, JUMPER, #22 AWG	529701	89536	529701	REF		
W7	WIRE, JUMPER, #22 AWG	529701	89536	529701	REF		
XF2	FUSE HOLDER, (BODY ONLY) 6.3A, 250V	602763	89536	602763	1		
XU8	SOCKET, 40-PIN	429282	09922	DILB40P-108	2		
XU9	SOCKET, 16-PIN	276535	91506	316-AG39D	8		
XU10	SOCKET, 16-PIN	276535	91506	316-AG39D	REF		
XU11	SOCKET, 16-PIN	276535	91506	316-AG39D	REF		
XU12	SOCKET, 16-PIN	276535	91506	316-AG39D	REF		
XU13	SOCKET, 16-PIN	276535	91506	316-AG39D	REF		
XU14	SOCKET, 16-PIN	276535	91506	316-AG39D	REF		
XU15	SOCKET, 16-PIN	276535	91506	316-AG39D	REF		
XU16	SOCKET, 16-PIN	276535	91506	316-AG39D	REF		
XU17	SOCKET, 28-PIN	448217	89536	448217	4		
XU19	SOCKET, 28-PIN	448217	89536	448217	REF		
XU20	SOCKET, 28-PIN	448217	89536	448217	REF		
XU21	SOCKET, 28-PIN	448217	89536	448217	REF		
XU22	SOCKET, 40-PIN	429282	09922	DILB40P-108	REF		
XU34	SOCKET, 14-PIN	370304	12040	MM74C906M	1		

Table 5-3. A2 Display PCB Assembly

REF DES	DESCRIPTION	FLUKE STOCK NO.	MFG SPLY CODE	MFG PART NO.	TOT QTY	REC QTY	NOTE
A2①	DISPLAY PCB ASSEMBLY FIGURE 5-3 (9000A-4002T)	579250	89536	579250	REF		
C1	CAP, CER, 0.1 UF +/-10%, 400V	447573	73445	C280MA F/A100K	1		
C2	CAP, ELECT, 10 UF -10/+50%, 25V	170266	73445	ET100X025A2	2		
C3	CAP, ELECT, 10 UF -10/+50%, 25V	170266	73445	ET100X025A2	REF		
C4	CAP, CER, 20 PF +/-10%	106369	56289	561CT2HBA102AE200K	1		
C5	CAP, CER, 0.22 UF +/-20%, 50V	519157	51406	RPE111Z5U224M50V	2		
C6	CAP, CER, 0.22 UF +/-20%, 50V	519157	51406	RPE111Z5U224M50V	REF		
DS1	LIGHT EMITTING DIODE	504761	14936	MV57124	5	1	
DS2	LIGHT EMITTING DIODE	504761	14936	MV57124	REF		
DS3	LIGHT EMITTING DIODE	504761	14936	MV57124	REF		
DS4	LIGHT EMITTING DIODE	504761	14936	MV57124	REF		
DS5	LIGHT EMITTING DIODE	504761	14936	MV57124	REF		
H1	SCREW, PHP, 4-40 X 3/8	183574	89536	183574	2		
H2	WASHER, FLAT #4	110775	89536	110775	2		
J1	CONNECTOR BODY	530154	89536	530154	2		
J2	CONNECTOR BODY	530154	89536	530154	REF		
MP1	CONNECTOR, COVER	530162	89536	530162	2		
MP2	SPACER, DISPLAY	577601	89536	577601	1		
Q1	TRANSISTOR, SI, PNP, SMALL SIGNAL	418707	04713	MPS56562	2	1	
Q2	TRANSISTOR, SI, PNP, SMALL SIGNAL	418707	04713	MPS56562	REF		
R1	RES, DEP. CAR, 47K +/-5%, 1/4W	573527	80031	CR251-4-5P47K	2		
R2	RES, DEP. CAR, 47K +/-5%, 1/4W	573527	80031	CR251-4-5P47K	REF		
R3	RES, DEP. CAR, 10K +/-5%, 1/4W	573394	80031	CR251-4-5P10K	2		
R4	RES, CAR. DEP, 180 +/-5%, 1/4W	573048	80031	CR251-4-5P180E	5		
R5	RES, CAR. DEP, 180 +/-5%, 1/4W	573048	80031	CR251-4-5P180E	REF		
R6	RES, CAR. DEP, 180 +/-5%, 1/4W	573048	80031	CR251-4-5P180E	REF		
R7	RES, CAR. DEP, 180 +/-5%, 1/4W	573048	80031	CR251-4-5P180E	REF		
R8	RES, CAR. DEP, 180 +/-5%, 1/4W	573048	80031	CR251-4-5P180E	REF		
R9	RES, DEP. CAR, 10K +/-5%, 1/4W	573394	80031	CR251-4-5P10K	REF		
R10	RES, DEP. CAR, 1.1K +/-5%, 1/4W	573188	80031	CR251-4-5P1K1	2		
R11	RES, DEP. CAR, 180K +/-5%, 1/4W	573626	80031	CR251-4-5P180K	2		
R12	RES, COMP, 56 +/-10%, 1/2W	109009	01121	RC20GF56 OKS	2		
R13	RES, DEP. CAR, 1.1K +/-5%, 1/4W	573188	80031	CR251-4-5P1K1	REF		
R14	RES, DEP. CAR, 180K +/-5%, 1/4W	573626	80031	CR251-4-5P180K	REF		
R15	RES, COMP, 56 +/-10%, 1/2W	109009	01121	RC20GF56 OKS	REF		
TP0	CONNECTOR, POST	267500	00779	86144-2	6		
TP1	CONNECTOR, POST	267500	00779	86144-2	REF		
TP2	CONNECTOR, POST	267500	00779	86144-2	REF		
TP3	CONNECTOR, POST	267500	00779	86144-2	REF		
TP4	CONNECTOR, POST	267500	00779	86144-2	REF		
TP5	CONNECTOR, POST	267500	00779	86144-2	REF		
U1①	IC, N-MOS, PERIPHERAL INTERFACE	535419	89536	535419	1	1	
U2①	IC, C-MOS, DUAL 4-BIT STATIC SHIFT RGSTR	340125	04713	MC14015CP	5	1	
U3①	IC, C-MOS, DUAL 4-BIT STATIC SHIFT RGSTR	340125	04713	MC14015CP	REF		
U4①	IC, C-MOS, DUAL 4-BIT STATIC SHIFT RGSTR	340125	04713	MC14015CP	REF		
U5①	IC, C-MOS, DUAL 4-BIT STATIC SHIFT RGSTR	340125	04713	MC14015CP	REF		
U6①	IC, C-MOS, DUAL 4-BIT STATIC SHIFT RGSTR	340125	04713	MC14015CP	REF		
U7	IC, FLUORESCENT DISPLAY DRIVER	535799	56289	UDN6118A	6	2	

Table 5-3. A2 Display PCB Assembly (cont)

REF DES	DESCRIPTION	FLUKE STOCK NO.	MFG SPLY CODE	MFG PART NO.	TOT QTY	REC QTY	N O T E
U8	IC, FLUORESCENT DISPLAY DRIVER	535799	56289	UDN6 118A	REF		
U9	IC, FLUORESCENT DISPLAY DRIVER	535799	56289	UDN6 118A	REF		
U10	IC, FLUORESCENT DISPLAY DRIVER	535799	56289	UDN6 118A	REF		
U11	IC, FLUORESCENT DISPLAY DRIVER	535799	56289	UDN6 118A	REF		
U12	IC, FLUORESCENT DISPLAY DRIVER	535799	56289	UDN6 118A	REF		
U13	IC, 8-BIT SHIFT REGISTER	524520	04713	MC14094BCP	2		1
U14	IC, 8-BIT SHIFT REGISTER	524520	04713	MC14094BCP	REF		
U15	IC, TTL, HEX D TYPE FLIP-FLOP	604264	01295	SN74174N	1		1
U16	IC, TTL, QUAD, 2-INPUT NOR GATE	393041	01295	SN74LS02N	1		1
U17	IC, TTL, HEX INVERTER, BUFFER/DRIVER	288605	01295	SN7416N	1		1
V1	DISPLAY, FLUORESCENT, 32 CHARACTER	535401	30315	FG326A2	1		1
W1	CABLE, KEYBOARD	579235	89536	579235	1		
W2	CABLE, DISPLAY	579227	89536	579227	1		
XU1	SOCKET, IC, 40-PIN	429282	09922	DILB40P-108	1		
Y1	CRYSTAL, 6 MHZ +/-0.015%	461665	89536	461655	1		1

Figure 5-3. A2 Display PCB Assembly

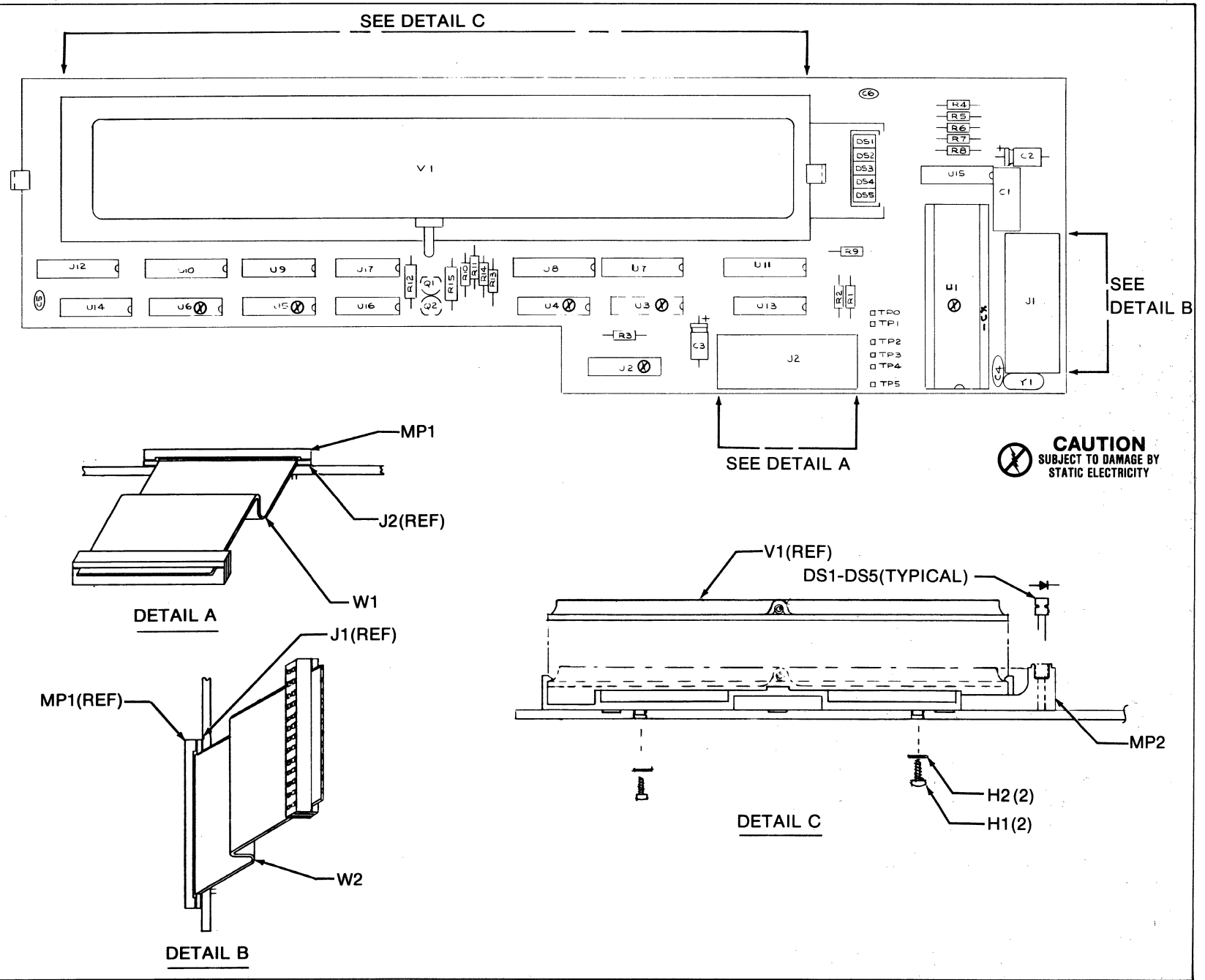

Table 5-4. A3 Keyboard Assembly

REF DES	DESCRIPTION	FLUKE STOCK NO.	MFG SPLY CODE	MFG PART NO.	TOT QTY	REC QTY	N O T E
A3	KEYBOARD ASSEMBLY FIGURE 5-4 (9010A-4033T)	579425	89536	579425			REF
J1	CONNECTOR, RIGHT ANGLE	512590	89536	512590	1		
LS1	TRANSDUCER, AUDIO	513101	89536	513101	1		
MP1	KEYTOP - LEARN	584284	89536	584284	1		
MP2	KEYTOP - RAM	584300	89536	584300	1		
MP3	KEYTOP - AUTO	584326	89536	584326	1		
MP4	KEYTOP - BUS	584359	89536	584359	1		
MP5	KEYTOP - ROM	584367	89536	584367	1		
MP6	KEYTOP - I/O	584292	89536	584292	1		
MP7	KEYTOP - ROM	584318	89536	584318	1		
MP8	KEYTOP - RAM LONG	584334	89536	584334	1		
MP9	KEYTOP - RAM SHORT	584342	89536	584342	1		
MP10	KEYTOP - I/O	584375	89536	584375	1		
MP11	KEYTOP - C 1100	584557	89536	584557	1		
MP12	KEYTOP - 8 1000	584516	89536	584516	1		
MP13	KEYTOP - 4 0100	584474	89536	584474	1		
MP14	KEYTOP - 0 0000	584433	89536	584433	1		
MP15	KEYTOP - ENTER/YES	584409	89536	584409	1		
MP16	KEYTOP - D 1101	584565	89536	584565	1		
MP17	KEYTOP - 9 1001	584524	89536	584524	1		
MP18	KEYTOP - 5 0101	584482	89536	584482	1		
MP19	KEYTOP - 1 0001	584441	89536	584441	1		
MP20	KEYTOP - CLEAR/NO	584417	89536	584417	1		
MP21	KEYTOP - E 1110	584573	89536	584573	1		
MP22	KEYTOP - A 1010	584532	89536	584532	1		
MP23	KEYTOP - 6 0110	584490	89536	584490	1		
MP24	KEYTOP - 2 0010	584458	89536	584458	1		
MP25	KEYTOP - PRIOR	584383	89536	584383	1		
MP26	KEYTOP - STS/CTL	584425	89536	584425	1		
MP27	KEYTOP - F 1111	584581	89536	584581	1		
MP28	KEYTOP - B 1011	584540	89536	584540	1		
MP29	KEYTOP - 7 0111	584508	89536	584508	1		
MP30	KEYTOP - 3 0011	584466	89536	584466	1		
MP31	KEYTOP - MORE	584391	89536	584391	1		
MP32	KEYTOP - READ	584607	89536	584607	1		
MP33	KEYTOP - RAMP	584623	89536	584623	1		
MP34	KEYTOP - TOGGL ADDR	584649	89536	584649	1		
MP35	KEYTOP - CONT.	584664	89536	584664	1		
MP36	KEYTOP - RPEAT	584680	89536	584680	1		
MP37	KEYTOP - LOOP	584706	89536	584706	1		
MP38	KEYTOP - WRITE	584615	89536	584615	1		
MP39	KEYTOP - WALK	584631	89536	584631	1		
MP40	KEYTOP - TOGGL DATA	584656	89536	584656	1		
MP41	KEYTOP - STOP	584672	89536	584672	1		
MP42	KEYTOP - RUN UUT	584698	89536	584698	1		
MP43	KEYTOP - SETUP	584599	89536	584599	1		
MP44	KEYTOP - PROG	584714	89536	584714	1		
MP45	KEYTOP - IF	584748	89536	584748	1		

Table 5-4. A3 Keyboard Assembly (cont)

REF DES	DESCRIPTION	FLUKE STOCK NO.	MFG SPLY CODE	MFG PART NO.	TOT QTY	REC QTY	N O T E
MP46	KEYTOP - DISPL	584789	89536	584789	1		
MP47	KEYTOP - AND	584797	89536	584797	1		
MP48	KEYTOP - OR	584805	89536	584805	1		
MP49	KEYTOP - READ PROBE	584920	89536	584920	1		
MP50	KEYTOP - EXEC	584771	89536	584771	1		
MP51	KEYTOP - >	584755	89536	584755	1		
MP52	KEYTOP - LABEL	584722	89536	584722	1		
MP53	KEYTOP - SHIFT LEFT	584813	89536	584813	1		
MP54	KEYTOP - SHIFT RIGHT	584821	89536	584821	1		
MP55	KEYTOP - REG	584839	89536	584839	1		
MP56	KEYTOP - AUX I/F	584938	89536	584938	1		
MP57	KEYTOP - =	584763	89536	584763	1		
MP58	KEYTOP - GO TO	584730	89536	584730	1		
MP59	KEYTOP - INCR	584847	89536	584847	1		
MP60	KEYTOP - DECR	584854	89536	584854	1		
MP61	KEYTOP - COMPL	584862	89536	584862	1		
MP62	KEYTOP - READ TAPE	584870	89536	584870	1		
MP63	KEYTOP - WRITE TAPE	584888	89536	584888	1		
MP64	KEYTOP - SYNC	584896	89536	584894	1		
MP65	KEYTOP - HIGH	584904	89536	584904	1		
MP66	KEYTOP - LOW	584912	89536	584912	1		
S1-64	SWITCH, KEYBOARD	513473	89536	513473	64	13	
S65	SWITCH, PUSH-PUSH	602219	89536	602219	2	1	
S66	SWITCH, PUSH-PUSH	602219	89536	602219	REF		

Figure 5-4. A3 Keyboard Assembly

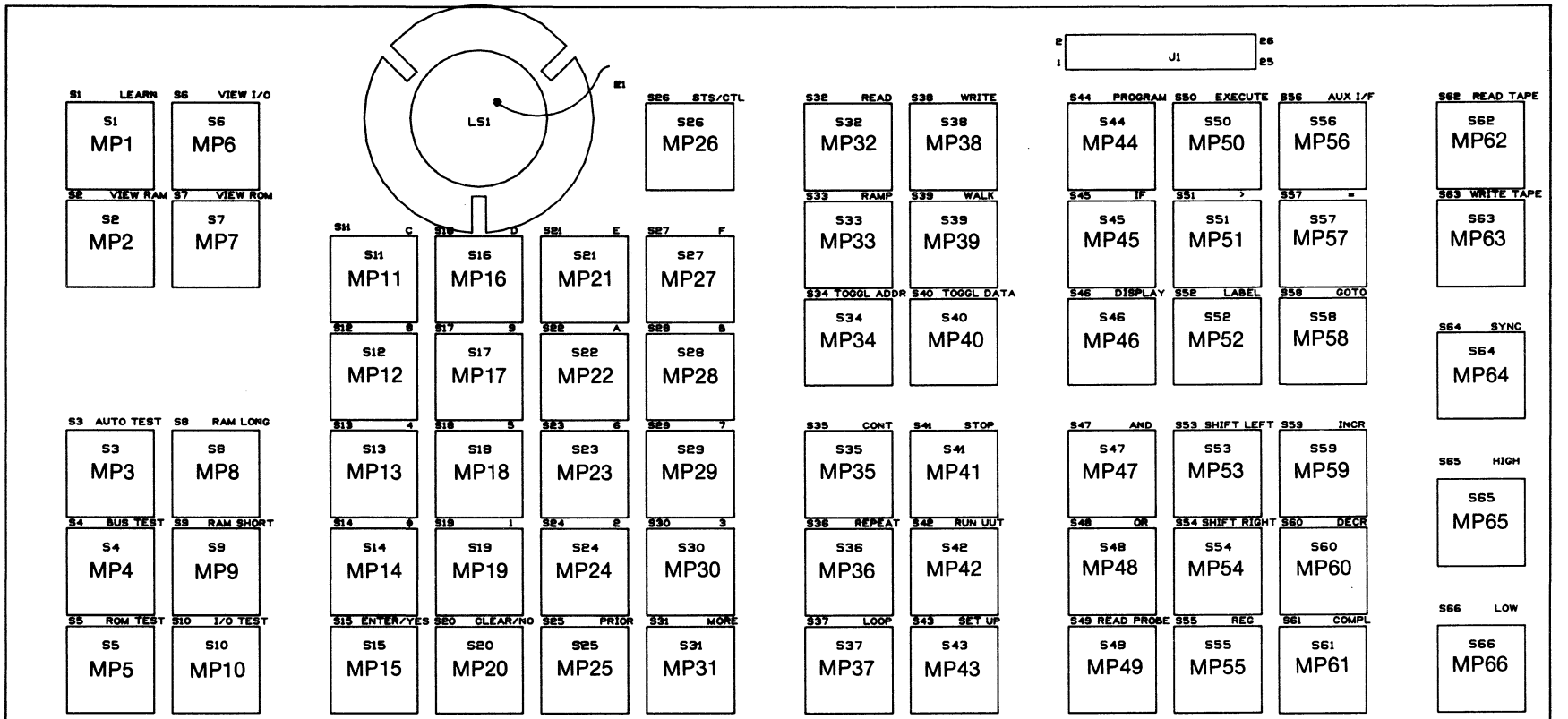

9010A-1633

Table 5-5. A4 Magnetic Tape PCB Assembly

REF DES	DESCRIPTION	FLUKE STOCK NO.	MFG SPLY CODE	MFG PART NO.	TOT QTY	REC QTY	N O T E
A4②	MAGNETIC TAPE PCB ASSEMBLY FIGURE 5-5 (9010A-4034T)	579441	89536	579441	REF		
C2	CAP, CER, 20 PF +/-10%, 500V	106369	56289	561CT2HBA102AE200K	1		
C3	CAP, CER, 0.22 UF +/-20%, 50V	519157	51406	RPE111Z5U224M50V	4		
C4	CAP, ELECT, 10 UF -10/+50%, 25V	170266	73445	ET100X025A2	3		
C5	CAP, CER, 0.22 UF +/-20%, 50V	519157	51406	RPE111Z5U224M50V	REF		
C6	CAP, ELECT, 10 UF -10/+50%, 25V	170266	73445	ET100X025A2	REF		
C7	CAP, ELECT, 4700 UF -10/+50%, 5V	572511	89536	572511	1		
C8	CAP, CER, 180 PF +/-10%, 1000V	105890	56289	C023B102E181M	1		
C9	CAP, CER, 0.22 UF +/-20%, 50V	519157	51406	RPE111Z5U224M50V	REF		
C10	CAP, TA, 4.7 UF +/-20%, 25V	161943	56289	196D475X0025KA1	2		
C11	CAP, TA, 4.7 UF +/-20%, 25V	161943	56289	196D475X0025KA1	REF		
C12	CAP, CER, 39 PF +/-5%, 1000V	417410	72982	858-000-R2G0-390J	1		
C13	CAP, CER, 0.01 UF +/-20%, 100V	407361	72982	8121-A100-W5R-103M	1		
C14	CAP, ELECT, 10 UF -10/+50%, 25V	170266	73445	ET100X025A2	REF		
C15	CAP, CER, 0.22 UF +/-20%, 50V	519157	51406	RPE111Z5U224M50V	REF		
C16	CAP, CER, 0.1 UF, GMV, 10V	368647	71590	UK10-104	1		
CR1-7	DIODE, SI, HI-SPEED SWITCHING	203323	04713	1N4448	7	2	
CR8	DIODE, SI, MULTI-PELLET	375485	09214	MPD300	2	1	
CR9	DIODE, SI, MULTI-PELLET	375485	09214	MPD300	REF		
H1	SCREW, PHP, 2-32 X 1/4	602128	89536	602128	3		
J1	CONNECTOR BODY	530154	89536	530154	1		
J2	CONNECTOR, POST	267500	00779	86144-2	21		
MP1	CONNECTOR COVER (W/J1)	530162	89536	530162	1		
MP2	RECORDER, MAGNETIC TAPE	574459	89536	574459	1		
Q1	TRANSISTOR, SI, NPN	330803	04713	MPS6560	1	1	
Q2-5	TRANSISTOR, SI, PNP	195974	04713	2N3906	4	1	
R1	RES, DEP. CAR, 10 +/-5%, 1/4W	572941	80031	CR251-4-5P10E	1		
R2	RES, DEP. CAR, 10K +/-5%, 1/4W	573394	80031	CR251-4-5P10K	5		
R3	RES, DEP. CAR, 10K +/-5%, 1/4W	573394	80031	CR251-4-5P10K	REF		
R4	RES, DEP. CAR, 110 +/-5%, 1/4W	442285	80031	CR251-4-5P110E	1		
R5	RES, DEP. CAR, 100K +/-5%, 1/4W	573584	80031	CR251-4-5P100K	9		
R6	RES, COMP, 1.2 +/-5%, 1/2W	218701	01121	EB1R25	1		
R7	RES, DEP. CAR, 360 +/-5%, 1/4W	573097	80031	CR251-4-5P360E	1		
R8	RES, DEP. CAR, 100K +/-5%, 1/4W	573584	80031	CR251-4-5P100K	REF		
R9	RES, DEP. CAR, 200 +/-5%, 1/4W	573055	80031	CR251-4-5P200E	4		
R10	RES, DEP. CAR, 10K +/-5%, 1/4W	573394	80031	CR251-4-5P10K	REF		
R11	RES, DEP. CAR, 200 +/-5%, 1/4W	573055	80031	CR251-4-5P200E	REF		
R12	RES, DEP. CAR, 100K +/-5%, 1/4W	573584	80031	CR251-4-5P100K	REF		
R13	RES, DEP. CAR, 180 +/-5%, 1/4W	573048	80031	CR251-4-5P180E	1		
R14	RES, VAR, 500 +/-20%, 1/2W	226068	02111	62-1-1-501	1		
R15	RES, DEP. CAR, 200 +/-5%, 1/4W	573055	80031	CR251-4-5P200E	REF		
R16	RES, DEP. CAR, 680 +/-5%, 1/4W	573154	80031	CR251-4-5P680	1		
R17	RES, DEP. CAR, 100K +/-5%, 1/4W	573584	80031	CR251-4-5P100K	REF		
R18	RES, DEP. CAR, 100 +/-5%, 1/4W	573014	80031	CR251-4-5P100E	6		
R19	RES, DEP. CAR, 100 +/-5%, 1/4W	573014	80031	CR251-4-5P100E	REF		
R20	RES, DEP. CAR, 100 +/-5%, 1/4W	573014	80031	CR251-4-5P100E	REF		
R21	RES, MTL. FILM, 499 +/-1%, 1/8W	289256	91637	CMF554490F	2		
R22	RES, MTL. FILM, 499 +/-1%, 1/8W	289256	91637	CMF554490F	REF		

Table 5-5. A4 Magnetic Tape PCB Assembly (cont)

REF DES	DESCRIPTION	FLUKE STOCK NO.	MFG SPLY CODE	MFG PART NO.	TOT QTY	REC QTY	N O T E
R23	RES, MTL. FILM, 100K +/-1%, 1/8W	248807	91637	CMF551003F	1		
R24	RES, MTL. FILM, 100K +/-1%, 1/8W	248807	91637	CMF551003F	REF		
R26	RES, DEP. CAR, 2K +/-5%, 1/4W	573238	80031	CR251-4-5P2K	2		
R27	RES, DEP. CAR, 100K +/-5%, 1/4W	573584	80031	CR251-4-5P100K	REF		
R28	RES, DEP. CAR, 100K +/-5%, 1/4W	573584	80031	CR251-4-5P100K	REF		
R29	RES, MTL. FILM, 40.2K +/-1%, 1/8W	235333	91637	CMF554022F	1		
R30	RES, MTL. FILM, 200K +/-1%, 1/8W	261701	91637	CMF552003F	1		
R31	RES, DEP. CAR, 27K +/-5%, 1/4W	573477	80031	CR251-4-5P27K	1		
R32	RES, DEP. CAR, 2K +/-5%, 1/4W	573238	80031	CR251-4-5P2K	REF		
R33	RES, DEP. CAR, 100K +/-5%, 1/4W	573584	80031	CR251-4-5P100K	REF		
R34	RES, DEP. CAR, 100K +/-5%, 1/4W	573584	80031	CR251-4-5P100K	REF		
R35	RES, MTL. FILM, 10K +/-1%, 1/8W	168260	91637	CMF551002F	2		
R36	RES, MTL. FILM, 10K +/-1%, 1/8W	168260	91637	CMF551002F	REF		
R37	RES, DEP. CAR, 20K +/-2%, 1/4W	573444	80031	CR251-4-2P20K	1		
R38	RES, DEP. CAR, 100 +/-5%, 1/4W	573014	80031	CR251-4-5P100E	REF		
R39	RES, DEP. CAR, 100 +/-5%, 1/4W	573014	80031	CR251-4-5P100E	REF		
R40	RES, DEP. CAR, 100K +/-5%, 1/4W	573584	80031	CR251-4-5P100K	REF		
R41	RES, DEP. CAR, 1.8K +/-5%, 1/4W	573220	80031	CR251-4-5P1K8	1		
R42	RES, DEP. CAR, 10K +/-5%, 1/4W	573394	80031	CR251-4-5P10K	REF		
R43	RES, DEP. CAR, 1K +/-5%, 1/4W	573170	80031	CR251-4-5P1K	1		
R44	RES, DEP. CAR, 200 +/-5%, 1/4W	573055	80031	CR251-4-5P200E	REF		
R45	RES, DEP. CAR, 100 +/-5%, 1/4W	573014	80031	CR251-4-5P100E	REF		
R46	RES, DEP. CAR, 10K +/-5%, 1/4W	573394	80031	CR251-4-5P10K	REF		
TP1-4	CONNECTOR, POST	267500	00779	86144-2	REF		
U1⊙	IC, N-MOS, PERIPHERAL INTERFACE	536094	89536	536094	1	1	
U2	IC, TTL, BUFFERS & INTERFACE GATES	524736	01295	SN74LS38N	2	1	
U3	IC, TTL, BUFFERS & INTERFACE GATES	524736	01295	SN74LS38N	REF		
U4	IC, LIN, ARRAY, QUAD, PNP, XSTR	477828	12040	DH3467CN <i>MPQ3467</i>	1	1	
U5	IC, LIN, OP-AMP	402669	12040	LM324N	1	1	
U6	IC, LIN, DC MOTOR SPEED REGULATOR	536383	89536	536383	1	1	
W1	CABLE, MAGNETIC TAPE (W/J2)	581801	89536	581801	1		
XU1	SOCKET, IC, 40-PIN	429282	09922	DILB40P-108	1		
Y1	CRYSTAL, 6 MHZ, +/-0.015%	461665	89536	461665	1	1	

Table 5-6. A7 Data Probe PCB Assembly

REF DES	DESCRIPTION	FLUKE STOCK NO.	MFG SPLY CODE	MFG PART NO.	TOT QTY	REC QTY	N O T E
A7	DATA PROBE ASSEMBLY FIGURE 5-6 (9000A-4091T)	580969	89536	580969		REF	
C1	CAP, CER, 33 PF +/-2%, 100V	354852	72982	8121-A100-COG-330G	1		
C2	CAP, CER, 39 UF -20/+80%, 50V	614552	89536	614552	2		
C3	CAP, CER, 39 UF -20/+80%, 50V	614552	89536	614552		REF	
CR1	DIODE, HI-SPEED SWITCHING	203323	04713	1N4448	2		1
CR2	DIODE, HI-SPEED SWITCHING	203323	04713	1N4448		REF	
L1	LAMP, SUB-MINATURE	574475	76854	14AS15	2		
L2	LAMP, SUB-MINATURE	574475	76854	14AS15		REF	
MP1	DECAL	585307	89536	585307	1		
MP2	PROBE, BODY	611814	89536	611814	1		
MP3	PROBE, CANOPY	580910	89536	580910	1		
MP4	LABEL, PROBE CAUTION	605816	89536	605816	1		
MP5	SPACER, SWAGE (NOT SHOWN)	584201	89536	584201	1		
Q1	TRANSISTOR, SI, PNP	483735	04713	MMBT3906	1		1
Q2	TRANSISTOR, SI, NPN	483743	04713	MMBT3904	1		1
R1	RES, MTL. FILM, 205K +/-1%, 1/8W	375931	91637	CMF552053F	1		
R2	RES, DEP. CAR, 220 +/-5%, 1/4W	342626	80031	CR251-4-5P220E	1		
R3	RES, MTL. FILM, 100K +/-1%, 1/8W	248807	91637	CMF551003F	1		
R4	RES, COMP, 10K +/-10%, 1/8W	246975	01121	BB1031	1		
W1	CABLE ASSEMBLY PROBE	583344	89536	583344	1		

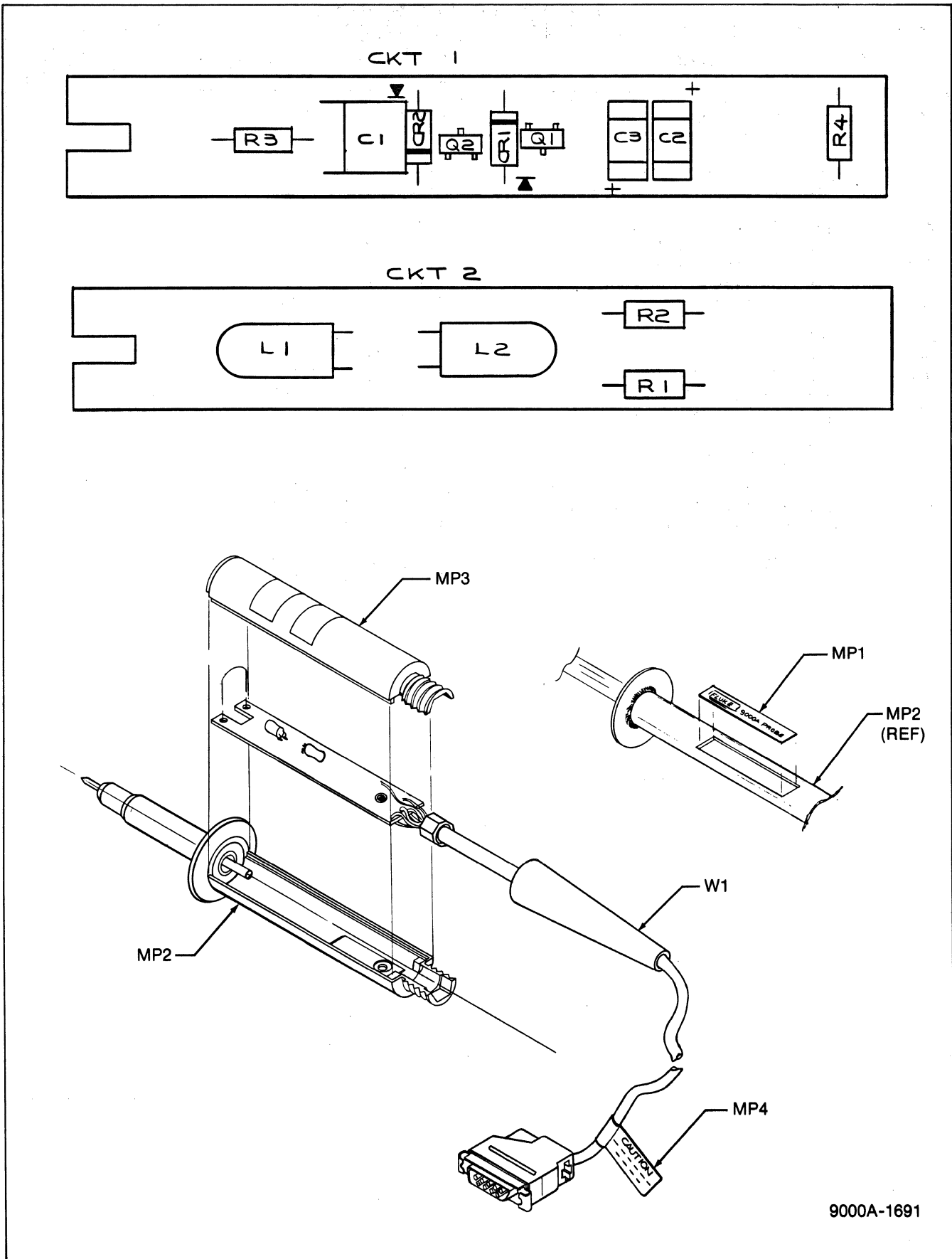

9000A-1691

Figure 5-6. A7 Data Probe PCB Assembly

Table 5-7. A10 Piggyback ROM PCB Assembly

REF DES	DESCRIPTION	FLUKE STOCK NO.	MFG SPLY CODE	MFG PART NO.	TOT QTY	REC QTY	NOTE
A10 ⊗	PIGGY BACK ROM PCB ASSEMBLY FIGURE 5-7 (9000A-4004)	613869	89536	613869	REF		
C1	CAP, CER, 0.22 UF +/-20%, 50V	519157	51406	RPE111Z5U224M50V	1		
P1	CONNECTOR, POST	513861	00779	1-87022-7	28		
U1 ⊗	IC, ROM	605071	89536	605071	1	1	
U2 ⊗	IC, ROM	605121	89536	605121	1	1	
W1	WIRE, 22 AWG, WHITE/RED	194386	89536	194386	A/R		
XU1	SOCKET, 28-PIN	448217	89536	448217	2		
XU2	SOCKET, 28-PIN	448217	89536	448217	REF		

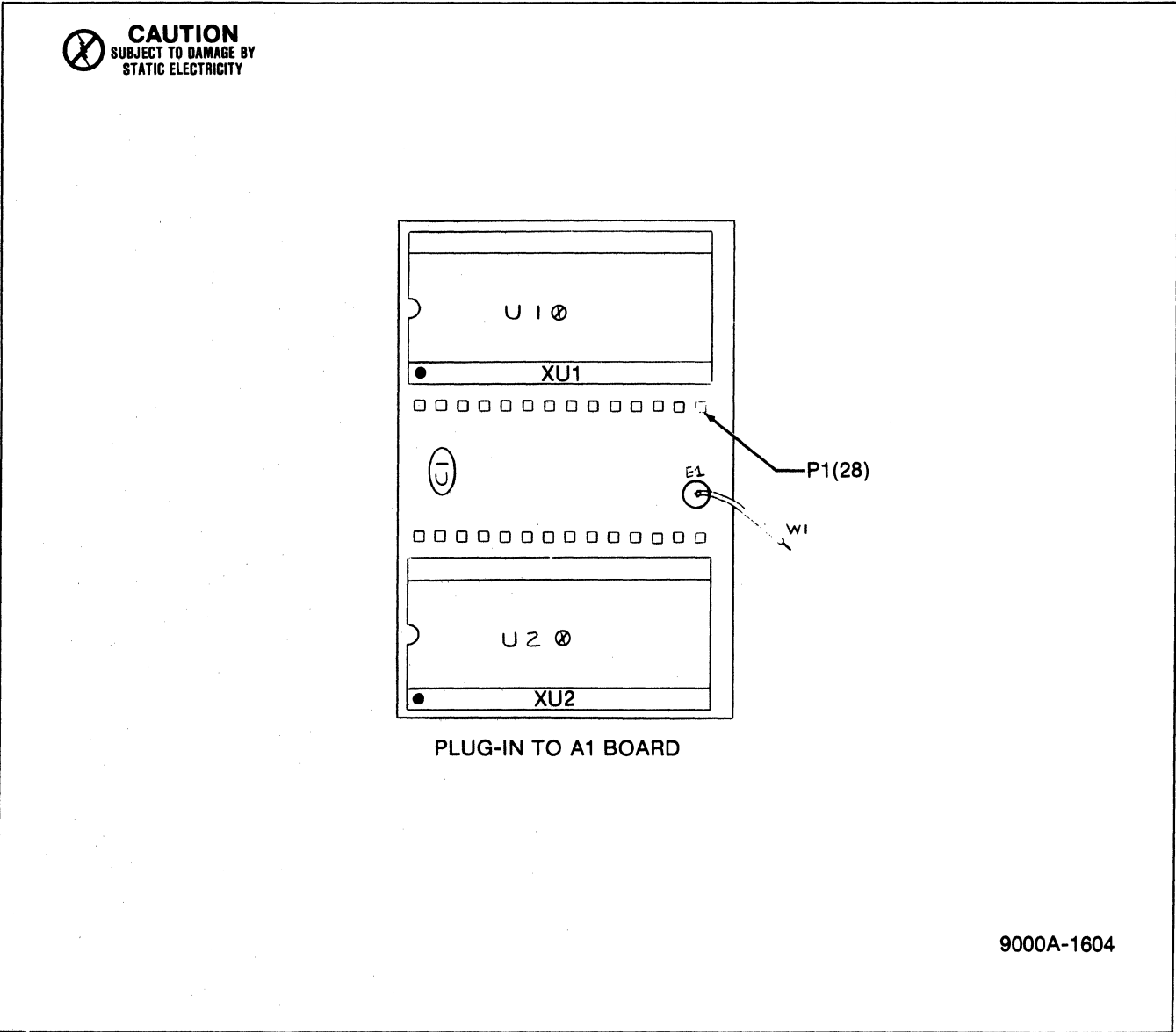

Figure 5-6. A10 Piggyback ROM PCB Assembly

Section 6 Option & Accessory Information

TABLE OF CONTENTS

OPTION/ MODEL NO.	DESCRIPTION	PAGE
-001	RS-232 Interface	001-1

6-1. INTRODUCTION

6-2. This section of the manual contains information concerning the options and accessories available for use with the Model 9010A Micro System Troubleshooter. It consists of an introductory section, an accessory section, and an option subsection.

6-3. ACCESSORIES

6-4. The accessories are fully documented in the Accessories subsection of the 9010A Operator Manual.

6-5. OPTIONS

6-6. Each option is documented in an individual subsection of this manual section. Each option subsection includes all maintenance information for the specific

option: theory of operation, calibration, general maintenance, performance test, troubleshooting, parts list, and schematics.

6-7. Unique page and paragraph numbering, which corresponds to the option number, facilitates subsection location. For example, a page numbered 001-1 is the first page of information for Option -001. A paragraph numbered 001-1 is the first paragraph concerning Option 001.

6-8. Subsections for options available at the time of this printing are included in this manual. Additional options will be available in the future. Contact your nearest Fluke sales representative for a current list of available options.

Option -001 RS-232 Interface

001-1. INTRODUCTION

001-2. Option -001 is an RS-232 Interface which consists of a printed circuit board assembly mounted on the 9010A Main Assembly, and a standard RS-232 connector mounted on the 9010A rear panel. The RS-232 Interface allows the 9010A to communicate with remote devices, such as a printer, a computer, or another 9010A via the rear panel connector. Data transmission is asynchronous, with operator-selectable baud rates, seven or eight data bits, one or two stop bits, and selectable odd, even or no parity. Refer to the 9010A Operator Manual for connection and operating details.

001-3. THEORY OF OPERATION

001-4. UART Control

001-5. The RS-232 Interface (Option -001) provides a standard communications interface port. The interface contains a UART (universal asynchronous receiver/transmitter) which performs the necessary parallel-to-serial and serial-to-parallel data conversion, and inserts stop bits and parity coding. Figure 001-1 shows that the data input lines (T0-T7) are connected via tri-state buffer U7 to the data bus. This buffer is constantly enabled. The status output lines: parity error (PE); framing error (FE); overrun error (DE); data received (DR); transmit buffer empty (TBE); and transmit register empty (TRE) are all buffered to the data bus via tri-state buffer U8. In addition to the six status lines, U8 always sends the upper bit (b7) low and the next bit (b6) high when a read status is performed. These two bits are used by the main microprocessor to detect the presence of the option card. The data output lines, and the status output lines of the UART, U1, are all connected to the microprocessor data bus, D0 - D7.

001-6. The microprocessor selects/addresses UART functions by means of the $\overline{I/O7}$ output of the I/O selector (described in Section 3) in conjunction with address lines A0 and A1, and the \overline{WR} (write) line. To read the UART

status on six lines (D0-D5) of the data bus, the microprocessor makes address line A0 low, and $\overline{I/O7}$ low, which enables U8 to place status on the bus. The UART reset line is tied to the mainframe Reset line via U4. In addition the DR (Data Received) line is tied via U4 to INT (interrupt) line for use in the 9020 mainframe only.

NOTE

Refer to Table 001-1 for a list of addressing protocol for the RS-232 Interface Assembly.

001-7. The TBRL (transit buffer register load) input of the UART is made low whenever the microprocessor issues a \overline{WR} (write) and the $\overline{I/O7}$ line is low. A low TBRL input loads the data byte present on the data input lines T0-T7 into the transmit buffer of the UART. The UART then transmits the byte in serial fashion via the TRO (transmitter register output) output.

001-8. The RRD (receiver register disable) input of the UART is held high by a high A1 address line whenever the microprocessor performs a write to the UART, or when the $\overline{I/O7}$ line is high. The high RRD input holds the UART data outputs (R0-R7) (to the data bus) in the high impedance state, allowing the UART data inputs (via U7) to accept write data placed on the data bus by the microprocessor or to be off when no UART transactions are taking place.

001-9. The \overline{DRR} (data register reset) input of the UART is made low by a low A1 address line and a low $\overline{I/O7}$ whenever the microprocessor performs a read from the UART. The low \overline{DRR} input notifies the UART that a read by the microprocessor has been performed. The UART resets its receive data register (connected to the data bus) and loads it with the next byte of serial data received via the RRI (receive register input) input.

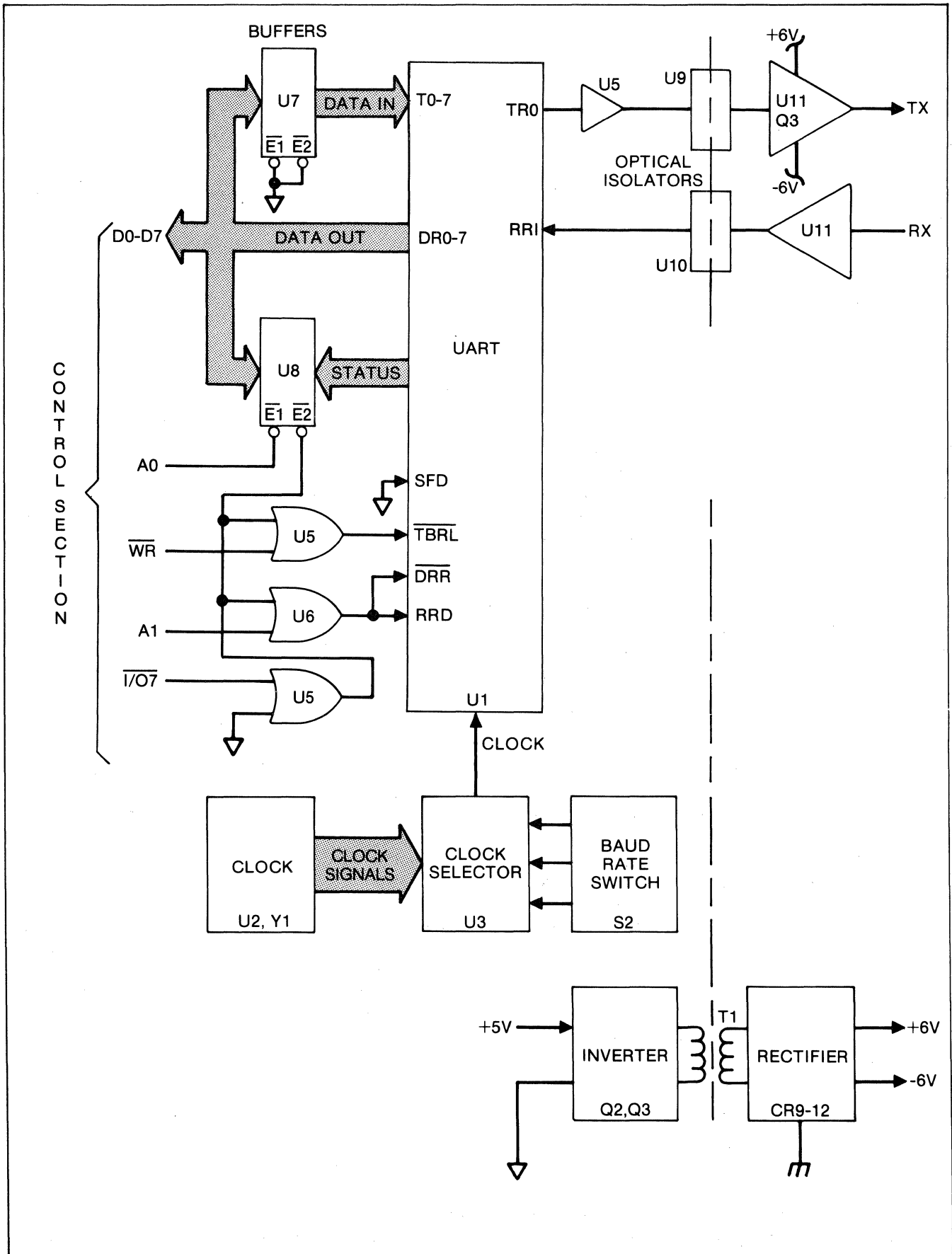

Figure 001-1. RS-232 Interface

Table 001-1. RS-232 Interface Protocol

ADDRESS	DATA	WRITE/READ	FUNCTION PERFORMED
100E1	Any	Read	Reads data received by the interface.
100E3	Any	Write	Writes data to be transmitted by the interface.
100E2	bbbbbbbb (binary)	Read	Causes the interface to respond with a bbbbbbbb status byte as follows: bbbbbbbb xxxxxx1 = Parity error xxxxxx1x = Framing error xxxxx1xx = Overrun error xxxx1xxx = Data received xxx1xxxx = Transmit buffer empty

001-10. UART Clock

001-11. Clock generator U2, in conjunction with crystal Y1, provides an array of clock signals required for operation at baud rates of 110 to 9600. Clock selector U3 receives all clock signals and, under control of the baud rate switch S2, connects the required clock signal to the UART. The clock signal into the UART is 16 times the selected baud rate. Switch S1 is used to select parity (PI), 1 or 2 stop bits (SBS), 7 or 8 bit communication (CLS1), and even or odd parity (EPE).

001-12. Line Driver/Receiver

001-13. Driver U5 feeds the serial output of the UART to optical isolator U9. The optical isolator provides a guard crossing to the line driver made up of Q3, U11 and associated components. The line driver utilizes +6 volt and -6 volt supplies to provide +6V and -6V output levels to meet RS-232 signal requirements. The line driver output connects to the TX (transmit) line of the RS-232 connector.

001-14. The RX (receive) line of the RS-232 connector connects to the line receiver U11. The line receiver drives optical isolator U10 to cross the guard and apply received data to the RRI (receiver register in) input of the UART.

001-15. Six-Volt Supply

001-16. A +6 volt and -6 volt supply provides the power necessary for the line driver and line receiver to transmit and receive data under RS-232 requirements. The supply comprises an inverter, the output of which is transformer coupled across the guard to a full-wave rectifier. The rectifier provides filtered +6 volt and -6 volt outputs.

001-17. Performance Checks

001-18. To perform checks on the RS-232 interface, gain access to the PCB assembly by removing the seven cover-retaining screws, and removing the cover. The location of the RS-232 interface PCB assembly is shown in Figure 4-7. Proceed as follows:

1. Verify the correct signal period (and a 50% duty cycle) for each setting of the baud rate switch, S2, in accordance with Table 001-2. Use an oscilloscope with a X10 probe connected to the clock input of the UART (universal asynchronous receiver/transmitter), pin 40 of U1 on the RS-232 interface PCB assembly.

NOTE

The frequency and period of the clock signal at pin 21 of U2 is 1.8432 MHz and 543 nanoseconds respectively.

2. Verify the presence of +6 volts across filter capacitor C5 and -6 volts across filter capacitor C4, both on the RS-232 Interface PCB Assembly.

3. Verify the proper operation of the RS-232 Interface by performing the following:

a. Disable the watchdog timer (U31 on the main assembly) by jumpering C16/R14 to TP12 (ground). This removes the reset input from the RS-232 interface assembly and allows it to operate.

b. Jumper pins 2 and 3 of the RS-232 connector to loop the transmit line back to the receive line.

c. Key-in programs 8, 7, 12, 13, and 16 listed in Table 001-3 and execute program 8. The program writes and reads data while verifying accuracy and correct status reporting.

001-19. If any of the performance or program checks fail, proceed as follows:

1. Swap the UART (U1) with a known-good device and rerun the program.

Table 001-2. Clock Signal Frequencies and Periods

SWITCH (S2) SETTING	BAUD RATE	FREQUENCY	PERIOD (APPROX)
0,8	110	1760 Hz	568 μ s
1,9	150	2400 Hz	417 μ s
2	300	4800 Hz	208 μ s
3	600	9600 Hz	104 μ s
4	1200	19.2 kHz	52 μ s
5	2400	38.4 kHz	26 μ s
6	4800	76.8 kHz	13 μ s
7	9600	153.6 kHz	6.5 μ s

2. Remove the jumper from pins 2 and 3 of the RS-232 connector. Jumper pins 20 and 25 of the UART (U1) to bypass the output buffers, isolators, and line receiver. Rerun the program; if the program passes, a problem is indicated in the output buffers, isolators, or line receiver.

3. Verify closures of parameter switches (S1) at pins 35, 36, 38, and 39 of the UART, U1 using the

tester 9010A probe in the free-running mode. Switches in the left (as viewed from the rear of the UUT) or open position should produce a logic high indication at the associated U1 pin. Refer to the schematic diagram contained in Section 8 for switch and UART pin relationships.

4. When prompted by the program, examine the opto-isolator circuits with an oscilloscope to verify that transmit data reaches the RS-232 connector at ± 6 -volt levels, and that received data reaches the UART (U1). Use signal ground (A5J2-5) for the common lead of the oscilloscope when checking at the RS-232C connector, and the 9010A ground when checking the UART.

001-19. LIST OF REPLACEABLE PARTS

001-20. A list of replaceable parts for the RS-232 Interface is given in Table 001-4. Refer to Section 5 of this manual for ordering information.

CAUTION



Indicated devices are subject to damage by static discharge.

Table 001-3. RS-232 Test (cont)

PROGRAM LISTING	COMMENTS
PROGRAM 8 1352 BYTES DPY-RS-232 TEST# EXECUTE PROGRAM 12 DPY-JUMP R14//C16 TO TP2 OR TP1 DPY-+2-CONT# STOP DPY-#SET PARITY ON, ODD; CONT STOP DPY-#SET 8 BITS, 1 STOP BIT; DPY-+CONT STOP DPY-#SET BAUD RATE = 9600, CONT STOP DPY-JUMPER RS232 PIN 2 TO 3#, DPY-+CONT STOP DPY-#MASTER CLEAR TEST EXECUTE PROGRAM 12 REG4 = 7000000 SYNC FREE-RUN DPY-POWER OFF UUT, PROBE U1-21, DPY-+ CONT STOP READ PROBE	delay disable watchdog timer rs-232 setup level mask - all states

Table 001-3. RS-232 Test (cont)

PROGRAM LISTING	COMMENTS
<pre> DPY-POWER ON UUT, CONT# STOP READ PROBE IF REG4 > REG0 AND REG4 GOTO D 0: LABEL 0 DPY-XMIT BUFFER STATUS TEST# EXECUTE PROGRAM 13 READ @ 100E2 IF REGE AND 10 = 10 GOTO 1 DPY-XMIT BUFFER FULL message GOTO E 1: LABEL 1 DPY-DATA RECV'D STATUS TEST# EXECUTE PROGRAM 13 READ @ 100E1 buffer) READ @ 100E2 IF REGE AND 8 = 0 GOTO 2 DPY-DATA RECV'D-NONE SENT- GOTO E 2: LABEL 2 DPY-OVERRUN STATUS TEST# EXECUTE PROGRAM 13 REGB = 10 REG1 = 55 EXECUTE PROGRAM 16 WRITE @ 100E3 = REG1 EXECUTE PROGRAM 16 WRITE @ 100E3 = REG1 EXECUTE PROGRAM 12 READ @ 100E2 IF REGE AND 4 = 4 GOTO 3 DPY-OVERRUN STATUS GOTO E 3: LABEL 3 DPY-DATA XMIT//REC'D TEST# EXECUTE PROGRAM 13 READ @ 100E1 IF REGE = REG1 GOTO 4 GOTO C 4: LABEL 4 REG1 = AA REGB = 10 EXECUTE PROGRAM 16 WRITE @ 100E3 = REG1 EXECUTE PROGRAM 12 READ @ 100E1 IF REGE = REG1 GOTO F GOTO C </pre>	<pre> check for low, invalid and high delay read rs-232 status ready for character? not ready - should be - display error delay read data (clear any character in buffer) read status check for no character received error - char. sent ready for char. mask wait until ready for char. write 55 to rs232 wait until ready for char. write 55 to rs232 delay read rs-232 status check for overrun status no overrun error delay read rs-232 data is data a 55? data error wait till ready for character send an aa delay read rs-232 data if data = aa goto F data error </pre>

Table 001-3. RS-232 Test (cont)

PROGRAM LISTING	COMMENTS
<pre> 5: LABEL 5 SYNC FREE-RUN DPY-PROBE U1-1,34,37-HIGH?0 IF REGO = 0 GOTO E DPY-PROBE U1-3,16-ALL LOW?0 IF REGO = 0 GOTO E DPY-PROBE U1-17,40-HI//LOW?0 IF REGO = 0 GOTO E DPY-#UART CONTROL TEST EXECUTE PROGRAM 12 SYNC ADDRESS REGB = 1 DPY-#PROBE U1-23 - CONT STOP REGA = 300 EXECUTE PROGRAM 7 IF REGA = 0 GOTO E REGB = 2 DPY-#PROBE U1-4 - CONT STOP REGA = 600 EXECUTE PROGRAM 7 IF REGA = 0 GOTO E REGB = 3 DPY-#PROBE U1-18 - CONT STOP REGA = 600 EXECUTE PROGRAM 7 IF REGA = 0 GOTO E DPY-#UART TRANSMIT TEST EXECUTE PROGRAM 12 DPY-PROBE U1-25 - CONT STOP REGA = 4 EXECUTE PROGRAM 7 IF REGA = 0 GOTO 6 GOTO A </pre>	<pre> check pins for logic high error - goto e check pins for logic low error - goto e check pins for toggle error - goto e delay u1-23 test pointer probe - tbrl expected sig = 300 gather sig error u1-4 test pointer expected sig gather sig error u1-18 test pointer expected sig. gather sig error delay expected event count = 4 gather count error </pre>
<pre> 6: LABEL 6 DPY-#U1-25 TRANSMIT ERROR - CON DPY-+T STOP GOTO F </pre>	
<pre> A: LABEL A SYNC FREE-RUN DPY-#BAD ITEM NOT FOUND; EXECUTE PROGRAM 13 DPY-#USE A SCOPE TO CHECK INPUT DPY-+ AND EXECUTE PROGRAM 13 DPY-#OUTPUT OPTO ISOLATORS. EXECUTE PROGRAM 13 DPY-A 55 IS BEING SENT CONTINUO DPY-+SLY# </pre>	<pre> no problem found - prompt user to use a scope to check opto - isolators. </pre>

Table 001-3. RS-232 Test (cont)

PROGRAM LISTING	COMMENTS
<pre> EXECUTE PROGRAM 13 REGO = 40 DPY-#HIT CLEAR//NO TO END TEST DPY-+%0 B: LABEL B IF REGO = 1D GOTO F WRITE @ 100E3 = 55 GOTO B C: LABEL C DPY-DATA ERROR-SENT \$1-REC'D \$E DPY-+-CONT# STOP GOTO 5 E: LABEL E DPY-+ ERROR-CONT# STOP GOTO 5 D: LABEL D DPY-#BAD MASTER CLEAR, CONT STOP GOTO F F: LABEL F DPY-#END RS-232-C TEST PROGRAM 7 172 BYTES READ PROBE WRITE @ 100E3 = AA READ @ 100E2 READ @ 100E1 READ PROBE REG1 = REGO AND 7000000 REG2 = REGO AND FFFF00 REG3 = REGO AND 7F IF REG1 = REGA GOTO A IF REG2 = REGA GOTO A IF REG3 = REGA GOTO A REGA = 0 GOTO B A: LABEL A REGA = 1 GOTO B B: LABEL B IF REGB = 1 GOTO C IF REGB = 2 GOTO D IF REGB = 3 GOTO E C: LABEL C DPY-U1-23 GOTO F D: LABEL D DPY-U1-4 GOTO F E: LABEL E DPY-U1-18 F: LABEL F </pre>	<pre> look for clear/no key send a 55 to rs-232 error messages read probe for rs232 checks clear sig, counter, logic level write aa to rs-232 uart read status read data logic level = reg1 sig = reg 2 count = reg 3 look for expected data - rega = 1, 2, or 3 error flag - rega = 0 check for u1-23 flag check for u1-4 flag check for u1-18 flag </pre>

Table 001-3. RS-232 Test (cont)

PROGRAM LISTING	COMMENTS
<pre> PROGRAM 12 21 BYTES REG1 = 40 1: LABEL 1 DEC REG1 IF REG1 > 0 GOTO 1 </pre>	<pre> delay approx. 1 second </pre>
<pre> PROGRAM 13 14 BYTES EXECUTE PROGRAM 12 EXECUTE PROGRAM 12 EXECUTE PROGRAM 12 </pre>	<pre> delay approx. 3 seconds </pre>
<pre> PROGRAM 16 32 BYTES 0: LABEL 0 READ @ 100E2 IF REGE AND REGB = REGB GOTO F GOTO 0 F: LABEL F </pre>	<pre> waits for status to match reg b read status is status = reg b; wait if not </pre>

Table 001-4. RS-232 Final Assembly

REF DES	DESCRIPTION	FLUKE STOCK NO.	MFG SPLY CODE	MFG PART NO.	TOT QTY	REC QTY	NOTE
-001	RS232 FINAL ASSEMBLY FIGURE 001-2 (9010A-001)	ORDER	BY	OPTION -001			
H1	NUT, HEX, 4-40	147611	89536	147611	3		
H2	SCREW, PHP, 4-40 X 5/16	152116	89536	152116	2		
H3	SCREW, RHP, 4-40 X 3/8	256164	89536	256164	2		
H4	WASHER, SPLIT-LK, #4	147603	89536	147603	3		
MP1	BRACKET	582163	89536	582163	1		
MP2	CABLE	581835	89536	581835	1		
MP3	PANEL, SUB	607168	89536	607168	1		

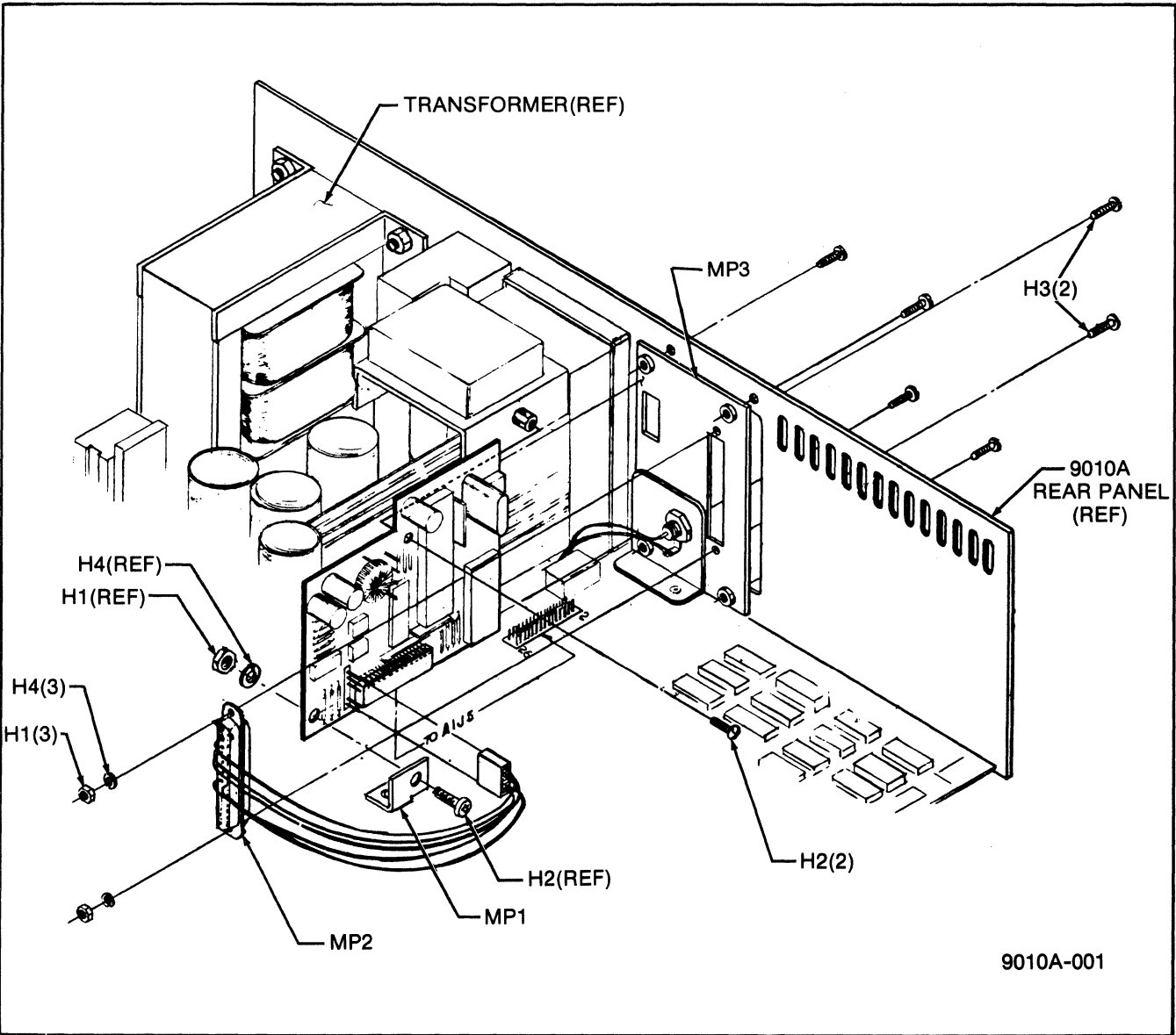

Figure 001-2. RS-232 Final Assembly

Table 001-5. RS-232 PCB Assembly

REF DES	DESCRIPTION	FLUKE STOCK NO.	MFG SPLY CODE	MFG PART NO.	TOT QTY	REC QTY	NOTE
-0010	RS232 PCB ASSEMBLY FIGURE 001-3 (9000A-4005T)	609339	89536	609339	1		
C1	CAP, CER, 0.22 UF +/-20%, 50V	519157	51406	RPE111Z5U224M50V	6		
C2	CAP, CER, 0.22 UF +/-20%, 50V	519157	51406	RPE111Z5U224M50V	REF		
C3	CAP, CER, 0.22 UF +/-20%, 50V	519157	51406	RPE111Z5U224M50V	REF		
C4	CAP, ELECT, 47 UF -10/+75%, 16V	519561	89536	519561	3	1	
C5	CAP, CER, 0.005 UF +/-20%, 50V	255471	51642	200-050-601-502M	1		
C6	CAP, ELECT, 47 UF -10/+75%, 16V	519561	89536	519561	REF		
C7	CAP, ELECT, 47 UF -10/+75%, 16V	519561	89536	519561	REF		
C8	CAP, CER, 0.22 UF +/-20%, 50V	519157	51406	RPE111Z5U224M50V	REF		
C9	CAP, CER, 0.22 UF +/-20%, 50V	519157	51406	RPE111Z5U224M50V	REF		
C10	CAP, CER, 0.22 UF +/-20%, 50V	519157	51406	RPE111Z5U224M50V	REF		
CR1-8	DIODE, SI, HI-SPEED SWITCHING	203323	07910	1N4448	8	2	
CR9	RECTIFIER BRIDGE, 1AMP	418582	83003	VMO8	1	1	
J2	CONNECTOR	267500	00779	87022-1	14		
P1	CONNECTOR, 26-CONTACT	543512	00779	86063-9	1		
Q1	TRANSISTOR, SI, NPN	272237	89536	272237	2	1	
Q2	TRANSISTOR, SI, NPN	272237	89536	272237	REF		
Q3	TRANSISTOR, SI, PNP	195974	04713	2N3906	1		
R1	RES, DEP. CAR, 390 +/-5%, 1/4W	573105	80031	CR251-4-5P390E	2		
R2	RES, DEP. CAR, 5.6K +/-5%, 1/4W	573337	80031	CR251-4-5P5K6	1		
R3	RES, DEP. CAR, 15K +/-5%, 1/4W	573428	80031	CR251-4-5P15K	1		
R4	RES, DEP. CAR, 47 +/-5%, 1/4W	572982	80031	CR251-4-5P47E	1		
R5	RES, COMP, 15M +/-5%, 1/4W	381491	01121	CB1565	1		
R6	RES, DEP. CAR, 1.5K +/-5%, 1/4W	573212	80031	CR251-4-5P1K5	1		
R7	RES, DEP. CAR, 12K +/-5%, 1/4W	573402	80031	CR251-4-5P12K	1		
R8	RES, DEP. CAR, 12K +/-5%, 1/4W	348847	80031	CR251-4-5P12K	1		
R9	RES, DEP. CAR, 620 +/-5%, 1/4W	442319	80031	CR251-4-5P620E	2		
R10	RES, DEP. CAR, 390 +/-5%, 1/4W	573105	80031	CR251-4-5P390E	REF		
R11	RES, DEP. CAR, 620 +/-5%, 1/4W	442319	80031	CR251-4-5P620E	REF		
R12	RES, DEP. CAR, 56K +/-5%, 1/4W	441626	80031	CR251-4-5P56K	1		
R13	RES, DEP. CAR, 3.3K +/-5%, 1/4W	348813	80031	CR251-4-5P3K3	1		
R14	RES, DEP. CAR, 1K +/-5%, 1/4W	573170	80031	CR251-4-5P1K	1		
R15	RES, DEP. CAR, 200 +/-5%, 1/4W	573055	80031	CR251-4-5P200E	1		
S1	SWITCH, 4-POS, DIP	495218	00779	435802-3	1	1	
S2	SWITCH, ROTARY	495614	00779	53919-2	1	1	
T1	TRANSFORMER, DC-DC	461863	89536	461863	1		
TP1-9	CONNECTOR	267500	00779	87022-1	REF		
TP11-14	CONNECTOR, TEST POINT	512889	02660	62395	4		
U10	IC, C-MOS, RECEIVER, TRANSMITTER	453464	32293	1M6402CPL	1	1	
U20	IC, BIT RATE GENERATOR	418921	04713	MC14411P	1	1	
U30	IC, 8 BIT MULTIPLEXER, W/3 STATE	504647	04713	MC4512BCP	1	1	
U4	IC, TTL, QUAD, 2-INPUT, POS NAND GATE	393033	01295	SN74LS00N	1	1	
U5	IC, TTL, QUAD, 2-INPUT POS OR GATE	393108	01295	SN74LS32N	1	1	
U7	IC, TTL, OCTAL BUFFER/LINE DRIVER	634105	04713	SN74LS541N	2	1	
U8	IC, TTL, OCTAL BUFFER/LINE DRIVER	634105	04713	SN74LS541N	REF		
U9	OPTO-ISOLATOR	407742	28480	HP5082-4351	2	1	
U10	OPTO-ISOLATOR	407742	28480	HP5082-4351	REF		
U11	IC, LINEAR, 5-TRANSISTOR ARRAY	248906	12040	LM3046N	1	1	

Table 001-5. RS-232 PCB Assembly (cont)

REF DES	DESCRIPTION	FLUKE STOCK NO.	MFG SPLY CODE	MFG PART NO.	TOT QTY	REC QTY	NOTE
XU1	SOCKET, IC, 40-PIN	429282	09922	DILB40P-108	1		
XU2	SOCKET, IC, 24-PIN	376236	91506	324-AG39D	1		
Y1	CRYSTAL, 1.8432 MHZ	424184	89536	424184	1	1	
Z1	RESISTOR NETWORK	485193	89536	485193	1	1	

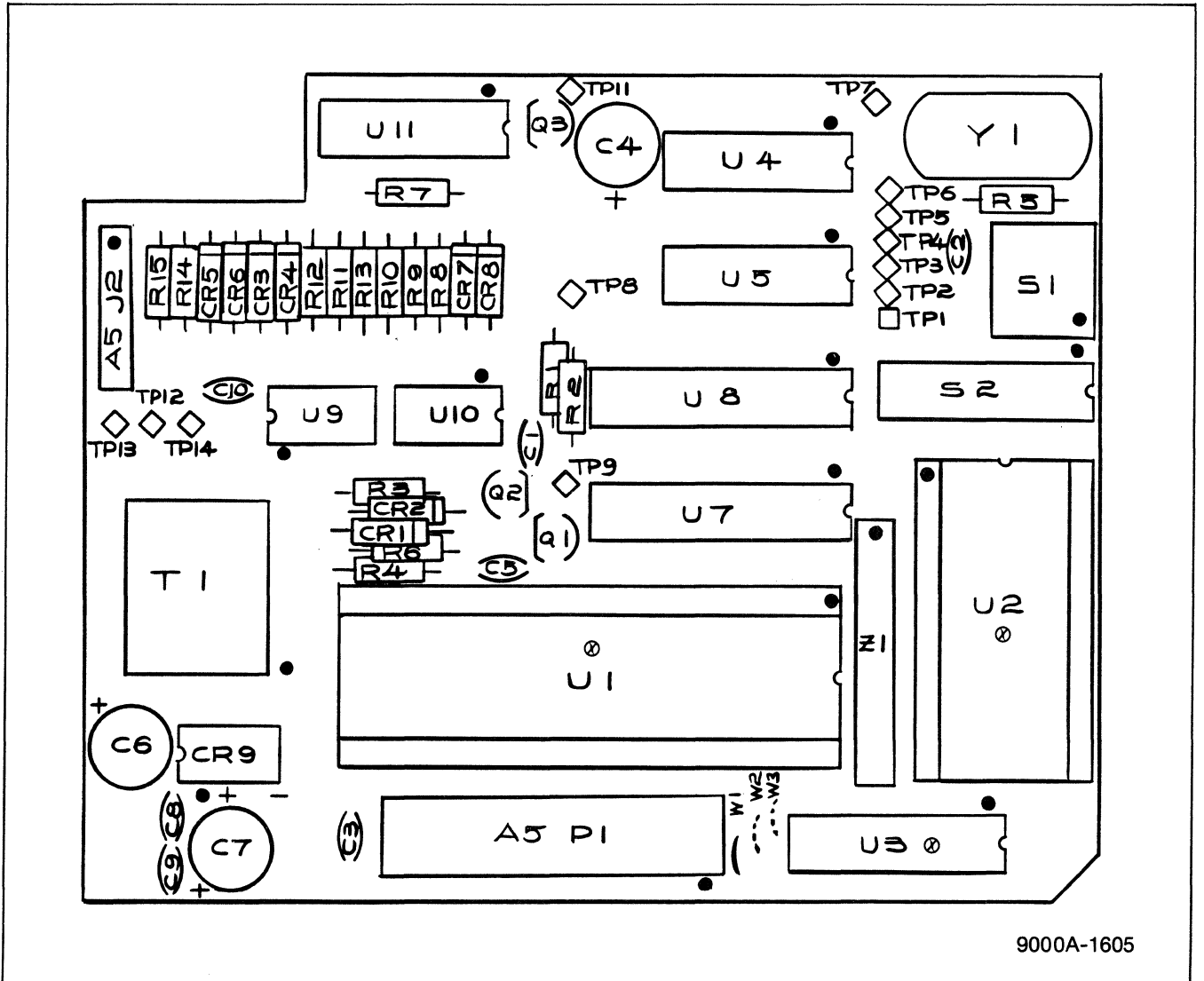

Figure 001-3. RS-232 PCB Assembly

Section 7

General Information

7-1. This section of the manual contains generalized user information as well as supplemental information to the List of Replaceable Parts contained in Section 5.

List of Abbreviations and Symbols

A or amp	ampere	hf	high frequency	(+) or pos	positive
ac	alternating current	Hz	hertz	pot	potentiometer
af	audio frequency	IC	integrated circuit	p-p	peak-to-peak
a/d	analog-to-digital	if	intermediate frequency	ppm	parts per million
assy	assembly	in	inch(es)	PROM	programmable read-only memory
AWG	american wire gauge	intl	internal	psi	pound-force per square inch
B	bel	I/O	input/output	RAM	random-access memory
bcd	binary coded decimal	k	kilo (10 ³)	rf	radio frequency
°C	Celsius	kHz	kilohertz	rms	root mean square
cap	capacitor	kΩ	kilohm(s)	ROM	read-only memory
ccw	counterclockwise	kV	kilovolt(s)	s or sec	second (time)
cer	ceramic	lf	low frequency	scope	oscilloscope
cermet	ceramic to metal(seal)	LED	light-emitting diode	SH	shield
ckt	circuit	LSB	least significant bit	Si	silicon
cm	centimeter	LSD	least significant digit	serno	serial number
cmrr	common mode rejection ratio	M	mega (10 ⁶)	sr	shift register
comp	composition	m	milli (10 ⁻³)	Ta	tantalum
cont	continue	mA	milliampere(s)	tb	terminal board
crt	cathode-ray tube	max	maximum	tc	temperature coefficient or temperature compensating
cw	clockwise	mf	metal film	tcxo	temperature compensated crystal oscillator
d/a	digital-to-analog	MHz	megahertz	tp	test point
dac	digital-to-analog converter	min	minimum	u or μ	micro (10 ⁻⁶)
dB	decibel	mm	millimeter	uhf	ultra high frequency
dc	direct current	ms	millisecond	us or μs	microsecond(s) (10 ⁻⁶)
dmm	digital multimeter	MSB	most significant bit	uut	unit under test
dvm	digital voltmeter	MSD	most significant digit	V	volt
elect	electrolytic	MTBF	mean time between failures	v	voltage
ext	external	MTTR	mean time to repair	var	variable
F	farad	mV	millivolt(s)	vco	voltage controlled oscillator
°F	Fahrenheit	mv	multivibrator	vhf	very high frequency
FET	Field-effect transistor	MΩ	megohm(s)	vlf	very low frequency
ff	flip-flop	n	nano (10 ⁻⁹)	W	watt(s)
freq	frequency	na	not applicable	ww	wire wound
FSN	federal stock number	NC	normally closed	xfmr	transformer
g	gram	(-) or neg	negative	xstr	transistor
G	giga (10 ⁹)	NO	normally open	xtal	crystal
gd	guard	ns	nanosecond	xtlo	crystal oscillator
Ge	germanium	opnl ampl	operational amplifier	Ω	ohm(s)
GHz	gigahertz	p	pico (10 ⁻¹²)	μ	micro (10 ⁻⁶)
gmV	guaranteed minimum value	para	paragraph		
gnd	ground	pcb	printed circuit board		
H	henry	pF	picofarad		
hd	heavy duty	pn	part number		

Federal Supply Codes for Manufacturers

00213 Nytronics Comp. Group Inc. Subsidiary of Nytronics Inc. Formerly Sage Electronics Rochester, New York	02660 Bunker Ramo Corp., Conn Div. Formerly Amphenol-Borg Electric Corp. Broadview, Illinois	04946 Standard Wire & Cable Los Angeles, California	06751 Components, Inc. Semcor Div. Phoenix, Arizona
00327 Welwyn International, Inc. Westlake, Ohio	02799 Areo Capacitors, Inc. Chatsworth, California	05082 Replaced by 94988	06860 Gould Automotive Div. City of Industry, California
00656 Aerovox Corp. New Bedford, Massachusetts	03508 General Electric Co. Semiconductor Products Syracuse, New York	05236 Jonathan Mfg. Co. Fullerton, California	06961 Vernitron Corp., Piezo Electric Div. Formerly Clevite Corp., Piezo Electric Div. Bedford, Ohio
00686 Film Capacitors, Inc. Passaic, New Jersey	03614 Replaced by 71400	05245 Components Corp. now Corcom, Inc. Chicago, Illinois	06980 Eimac Div. Varian Associates San Carlos, California
00779 AMP Inc. Harrisburg, Pennsylvania	03651 Replaced by 44655	05277 Westinghouse Electric Corp. Semiconductor Div. Youngwood, Pennsylvania	07047 The Ross Milton Co. South Hampton, Pennsylvania
01121 Allen-Bradley Co. Milwaukee, Wisconsin	03797 Eldema Div. Genisco Technology Corp. Compton, California	05278 Replaced by 43543	07115 Replaced by 14674
01281 TRW Electronic Comp. Semiconductor Operations Lawndale, California	03877 Transistron Electronic Corp. Wakefield, Massachusetts	05279 Southwest Machine & Plastic Co. Glendora, California	07138 Westinghouse Electric Corp., Electronic Tube Div. Horsehead, New York
01295 Texas Instruments, Inc. Semiconductor Group Dallas, Texas	03888 KDI Pyrofilm Corp. Whippany, New Jersey	05397 Union Carbide Corp. Materials Systems Div. New York, New York	07233 TRW Electronic Components Cinch Graphic City of Industry, California
01537 Motorola Communications & Electronics Inc. Franklin Park, Illinois	03911 Clairex Electronics Div. Clairex Corp. Mt. Vernon, New York	05571 Use 56289 Sprague Electric Co. Pacific Div. Los Angeles, California	07256 Silicon Transistor Corp. Div. of BBF Group Inc. Chelmsford, Massachusetts
01686 RCL Electronics Inc. Manchester, New Hampshire	03980 Muirhead Inc. Mountainside, New Jersey	05574 Viking Industries Chatsworth, California	07261 Aumet Corp. Culver City, California
01730 Replaced by 73586	04009 Arrow Hart Inc. Hartford, Connecticut	05704 Replaced by 16258	07263 Fairchild Semiconductor Div. of Fairchild Camera & Instrument Corp. Mountain View, California
01884 Use 56289 Sprague Electric Co. Dearborn Electronic Div. Lockwood, Florida	04062 Replaced by 72136	05820 Wakefield Engineering Inc. Wakefield, Massachusetts	07344 Bircher Co., Inc. Rochester, New York
02114 Ferroxcube Corp. Saugerties, New York	04202 Replaced by 81312	06001 General Electric Co. Electronic Capacitor & Battery Products Dept. Columbia, South Carolina	07597 Burndy Corp. Tape/Cable Div. Rochester, New York
02131 General Instrument Corp. Harris ASW Div. Westwood, Maine	04217 Essex International Inc. Wire & Cable Div. Anaheim, California	06136 Replaced by 63743	07792 Lerma Engineering Corp. Northampton, Massachusetts
02395 Rason Mfg. Co. Brooklyn, New York	04221 Aemco, Div. of Midtex Inc. Mankato, Minnesota	06383 Panduit Corp. Tinley Park, Illinois	07910 Teledyne Semiconductor Formerly Continental Device Hawthorne, California
02533 Snelgrove, C.R. Co., Ltd. Don Mills, Ontario, Canada M3B 1M2	04222 AVX Ceramics Div. AVX Corp. Myrtle Beach, Florida	06473 Bunker Ramo Corp. Amphenol SAMS Div. Chatsworth, California	07933 Use 49956 Raytheon Co. Semiconductor Div. HQ Mountain View, California
02606 Fenwal Labs Div. of Travenal Labs. Morton Grove, Illinois	04423 Telonic Industries Laguna Beach, California	06555 Beede Electrical Instrument Co. Penacook, New Hampshire	08225 Industro Transistor Corp. Long Island City, New York
	04645 Replaced by 75376	06739 Electron Corp. Littleton, Colorado	
	04713 Motorola Inc. Semiconductor Products Phoenix, Arizona	06743 Clevite Corp. Cleveland, Ohio	

Federal Supply Codes for Manufacturers (cont)

08261 Spectra Strip Corp. Garden Grove, California	11726 Qualidyne Corp. Santa Clara, California	13606 Use 56289 Sprague Electric Co. Transistor Div. Concord, New Hampshire	16299 Corning Glass Electronic Components Div. Raleigh, North Carolina
08530 Reliance Mica Corp. Brooklyn, New York	12014 Chicago Rivet & Machine Co. Bellwood, Illinois	13839 Replaced by 23732	16332 Replaced by 28478
08806 General Electric Co. Miniature Lamp Products Dept Cleveland, Ohio	12040 National Semiconductor Corp. Danbury, Connecticut	14099 Semtech Corp. Newbury Park, California	16473 Cambridge Scientific Ind. Div. of Chemed Corporation Cambridge, Maryland
08863 Nylomatic Corp. Norrisville, Pennsylvania	12060 Diodes, Inc. Chatsworth, California	14140 Edison Electronic Div. Mc Gray-Edison Co. Manchester, New Hampshire	16742 Paramount Plastics Fabricators, Inc. Downey, California
08988 Use 53085 Skottie Electronics Inc. Archbald, Pennsylvania	12136 Philadelphia Handle Co. Camden, New Jersey	14193 Cal-R-Inc. formerly California Resistor, Corp. Santa Monica, California	16758 Delco Electronics Div. of General Motors Corp. Kokomo, Indiana
09214 G.E. Co. Semi-Conductor Products Dept. Power Semi-Conductor Products OPN Sec. Auburn, New York	12300 Potter-Brumfield Div. AMF Canada LTD. Guelph, Ontario, Canada	14298 American Components, Inc. an Insilco Co. Conshohocken, Pennsylvania	17001 Replaced by 71468
09353 C and K Components Watertown, Massachusetts	12327 Freeway Corp. formerly Freeway Washer & Stamping Co. Cleveland, Ohio	14655 Cornell-Dublier Electronics Division of Federal Pacific Electric Co. Govt. Control Dept. Newark, New Jersey	17069 Circuit Structures Lab. Burbank, California
09423 Scientific Components, Inc. Santa Barbara, California	12443 The Budd Co. Polychem Products Plastic Products Div. Bridgeport, Pennsylvania	14752 Electro Cube Inc. San Gabriel, California	17338 High Pressure Eng. Co., Inc. Oklahoma City, Oklahoma
09922 Burndy Corp. Norwalk, Connecticut	12615 U.S. Terminals Inc. Cincinnati, Ohio	14869 Replaced by 96853	17545 Atlantic Semiconductors, Inc. Asbury Park, New Jersey
09969 Dale Electronics Inc. Yankton, S. Dakota	12617 Hamlin Inc. Lake Mills, Wisconsin	14936 General Instrument Corp. Semi Conductor Products Group Hicksville, New York	17856 Siliconix, Inc. Santa Clara, California
10059 Barker Engineering Corp. Formerly Amerace, Amerace ESNA Corp. Kenilworth, New Jersey	12697 Clarostat Mfg. Co. Dover, New Hampshire	15636 Elec-Trol Inc. Saugus, California	17870 Replaced by 14140
11236 CTS of Berne Berne, Indiana	12749 James Electronics Chicago, Illinois	15801 Fenwal Electronics Inc. Div. of Kidde Walter and Co., Inc. Framingham, Massachusetts	18178 Vactec Inc. Maryland Heights, Missouri
11237 CTS Keene Inc. Paso Robles, California	12856 Micrometals Sierra Madre, California	15818 Teledyne Semiconductors, formerly Amelco Semiconductor Mountain View, California	18324 Signetics Corp. Sunnyvale, California
11358 CBS Electronic Div. Columbia Broadcasting System Newburyport, Minnesota	12954 Dickson Electronics Corp. Scottsdale, Arizona	15849 Litton Systems Inc. Useco Div. formerly Useco Inc. Van Nuys, California	18612 Vishay Resistor Products Div. Vishay Intertechnology Inc. Malvern, Pennsylvania
11403 Best Products Co. Chicago, Illinois	12969 Unitrode Corp. Watertown, Massachusetts	15898 International Business Machines Corp. Essex Junction, Vermont	18736 Voltronics Corp. Hanover, New Jersey
11503 Keystone Columbia Inc. Warren, Michigan	13103 Thermalloy Co., Inc. Dallas, Texas	15909 Replaced by 14140	18927 GTE Sylvania Inc. Precision Material Group Parts Division Titusville, Pennsylvania
11532 Teledyne Relays Hawthorne, California	13327 Solitron Devices Inc. Tappan, New York	16258 Space-Lok Inc. Burbank, California	19451 Perine Machinery & Supply Co. Seattle, Washington
11711 General Instrument Corp. Rectifier Division Hicksville, New York	13511 Amphenol Cadre Div. Bunker-Ramo Corp. Los Gatos, California		19701 Electro-Midland Corp. Mepco-Electra Inc. Mineral Wells, Texas
			20584 Enochs Mfg. Inc. Indianapolis, Indiana

Federal Supply Codes for Manufacturers (cont)

20891 Self-Organizing Systems, Inc. Dallas, Texas	28480 Hewlett Packard Co. Corporate HQ Palo Alto, California	43543 Nytronics Inc. Transformer Co. Div. Geneva, New York	70903 Belden Corp. Geneva, Illinois
21604 Bucheye Stamping Co. Columbus, Ohio	28520 Heyman Mfg. Co. Kenilworth, New Jersey	44655 Ohmite Mfg. Co. Skokie, Illinois	71002 Birnback Radio Co., Inc. Freeport, New York
21845 Solitron Devices Inc. Transistor Division Riveria Beach, Florida	29083 Monsanto, Co., Inc. Santa Clara, California	49671 RCA Corp. New York, New York	71400 Bussmann Mfg. Div. of McGraw-Edison Co. Saint Louis, Missouri
22767 ITT Semiconductors Palo Alto, California	29604 Stackpole Components Co. Raleigh, North Carolina	49956 Raytheon Company Lexington, Massachusetts	71450 CTS Corp. Elkhart, Indiana
23050 Product Comp. Corp. Mount Vernon, New York	30148 AB Enterprise Inc. Ahoskie, North Carolina	50088 Mostek Corp. Carrollton, Texas	71468 ITT Cannon Electric Inc. Santa Ana, California
23732 Tracor Inc. Rockville, Maryland	30323 Illinois Tool Works, Inc. Chicago, Illinois	50579 Litronix Inc. Cupertino, California	71482 Clare, C.P. & Co. Chicago, Illinois
23880 Stanford Applied Engrng. Santa Clara, California	31091 Optimax Inc. Colmar, Pennsylvania	51605 Scientific Components Inc. Linden, New Jersey	71590 Centrelab Electronics Div. of Globe Union Inc. Milwaukee, Wisconsin
23936 Pamotor Div., Wm. J. Purdy Co. Burlingame, California	32539 Mura Corp. Great Neck, New York	53021 Sangamo Electric Co. Springfield, Illinois	71707 Coto Coil Co., Inc. Providence, Rhode Island
24248 Replaced by 94222	32767 Griffith Plastic Corp. Burlingame, California	54294 Cutler-Hammer Inc. formerly Shallcross, A Cutter-Hammer Co. Selma, North Carolina	71744 Chicago Miniature Lamp Works Chicago, Illinois
24355 Analog Devices Inc. Norwood, Massachusetts	32879 Advanced Mechanical Components Northridge, California	55026 Simpson Electric Co. Div. of Am. Gage and Mach. Co. Elgin, Illinois	71785 TRW Electronics Components Cinch Connector Operations Div. Elk Grove Village Chicago, Illinois
24655 General Radio Concord, Massachusetts	32897 Erie Technological Products, Inc. Frequency Control Div. Carlisle, Pennsylvania	56289 Sprague Electric Co. North Adams, Massachusetts	72005 Wilber B. Driver Co. Newark, New Jersey
24759 Lenox-Fugle Electronics Inc. South Plainfield, New Jersey	32997 Bourns Inc. Trimpot Products Division Riverside, California	58474 Superior Electric Co. Bristol, Connecticut	72092 Replaced by 06980
25088 Siemen Corp. Isilen, New Jersey	33173 General Electric Co. Products Dept. Owensboro, Kentucky	60399 Torin Corp. formerly Torrington Mfg. Co. Torrington, Connecticut	72136 Electro Motive Mfg. Co. Williamantic, Connecticut
25403 Amperex Electronic Corp. Semiconductor & Micro-Circuits Div. Slatersville, Rhode Island	34333 Silicon General Westminister, California	63743 Ward Leonard Electric Co., Inc. Mount Vernon, New York	72259 Nytronics Inc. Pelham Manor, New Jersey
27014 National Semiconductor Corp. Santa Clara, California	34335 Advanced Micro Devices Sunnyvale, California	64834 West Mfg. Co. San Francisco, California	72619 Dialight Div. Amperex Electronic Corp. Brooklyn, New York
27264 Molex Products Downers Grove, Illinois	34802 Electromotive Inc. Kenilworth, New Jersey	65092 Weston Instruments Inc. Newark, New Jersey	72653 G.C. Electronics Div. of Hydrometals, Inc. Brooklyn, New York
28213 Minnesota Mining & Mfg. Co. Consumer Products Div. St. Paul, Minnesota	37942 P.R. Mallory & Co., Inc. Indianapolis, Indiana	66150 Winslow Tele-Tronics Inc. Eaton Town, New Jersey	72665 Replaced by 90303
28425 Serv-/Link formerly Bohannan Industries Fort Worth, Texas	42498 National Radio Melrose, Massachusetts	70485 Atlantic India Rubber Works Chicago, Illinois	72794 Dzus Fastener Co., Inc. West Islip, New York
28478 Deltrol Controls Div. Deltrol Corporation Milwaukee, Wisconsin		70563 Amperite Company Union City, New Jersey	72928 Gulton Ind. Inc. Gudeman Div. Chicago, Illinois

Federal Supply Codes for Manufacturers (cont)

72982 Erie Tech. Products Inc. Erie, Pennsylvania	75382 Kulka Electric Corp. Mount Vernon, New York	80583 Hammarlund Mfg. Co., Inc. Red Bank, New Jersey	83594 Burroughs Corp. Electronic Components Div. Plainfield, New Jersey
73138 Bechman Instrument Inc. Helipot Division Fullerton, California	75915 Littlefuse Inc. Des Plaines, Illinois	80640 Arnold Stevens, Inc. South Boston, Massachusetts	83740 Union Carbide Corp. Battery Products Div. formerly Consumer Products Div. New York, New York
73293 Hughes Aircraft Co. Electron Dynamics Div. Torrance, California	76854 Oak Industries Inc. Switch Div. Crystal Lake, Illinois	81073 Grayhill, Inc. La Grange, Illinois	84171 Arco Electronics Great Neck, New York
73445 Amperex Electronic Corp. Hicksville, New York	77342 AMF Inc. Potter & Brumfield Div. Princeton, Indiana	81312 Winchester Electronics Div. of Litton Industries Inc. Oakville, Connecticut	84411 TRW Electronic Components TRW Capacitors Ogallala, Nebraska
73559 Carling Electric Inc. West Hartford, Connecticut	77638 General Instrument Corp. Rectifier Division Brooklyn, New York	81483 Therm-O-Disc Inc. Mansfield, Ohio	84613 Fuse Indicator Corp. Rockville, Maryland
73586 Circle F Industries Trenton, New Jersey	77969 Rubbercraft Corp. of CA. LTD. Torrance, California	81483 International Rectifier Corp. Los Angeles, California	84682 Essex International Inc. Industrial Wire Div. Peabody, Massachusetts
73734 Federal Screw Products, Inc. Chicago, Illinois	78189 Shakeproof Div. of Illinois Tool Works Inc. Elgin, Illinois	81590 Korry Mfg. Co. Seattle, Washington	86577 Precision Metal Products of Malden Inc. Stoneham, Massachusetts
73743 Fischer Special Mfg. Co. Cincinnati, Ohio	78277 Sigma Instruments, Inc. South Braintree, Massachusetts	81741 Chicago Lock Co. Chicago, Illinois	86684 Radio Corp. of America Electronic Components Div. Harrison, New Jersey
73899 JFD Electronics Co. Components Corp. Brooklyn, New York	78488 Stackpole Carbon Co. Saint Marys, Pennsylvania	82305 Palmer Electronics Corp. South Gate, California	86928 Seastrom Mfg. Co., Inc. Glendale, California
73949 Guardian Electric Mfg. Co. Chicago, Illinois	78553 Eaton Corp. Engineered Fastener Div. Tinnerman Plant Cleveland, Ohio	82389 Switchcraft Inc. Chicago, Illinois	87034 Illuminated Products Inc. Subsidiary of Oak Industries Inc. Anaheim, California
74199 Quan Nichols Co. Chicago, Illinois	79136 Waldes Kohinoor Inc. Long Island City, New York	82415 North American Phillips Controls Corp. Frederick, Maryland	88219 Gould Inc. Industrial Div. Trenton, New Jersey
74217 Radio Switch Corp. Marlboro, New Jersey	79497 Western Rubber Company Goshen, Indiana	82872 Roanwell Corp. New York, New York	88245 Litton Systems Inc. Useco Div. Van Nuys, California
74276 Signalite Div. General Instrument Corp. Neptune, New Jersey	79963 Zierick Mfg. Corp. Mt. Kisko, New York	82877 Rotron Inc. Woodstock, New York	88419 Cornell-Dubilier Electronic Div. Federal Pacific Co. Fuquay-Varian, North Carolina
74306 Piezo Crystal Co. Carlisle, Pennsylvania	80031 Electro-Midland Corp. Mepco Div. A North American Phillips Co. Norristown, New Jersey	82879 ITT Royal Electric Div. Pawtucket, Rhode Island	88486 Plastic Wire & Cable Jewitt City, Connecticut
74542 Hoyt Elect. Instr. Works Penacook, New Hampshire	80145 LFE Corp., Process Control Div. formerly API Instrument Co. Chesterland, Ohio	83003 Varo Inc. Garland, Texas	88690 Replaced by 04217
74970 Johnson E.F., Co. Waseca, Minnesota	80183 Use 56289 Sprague Products North Adams, Massachusetts	83058 The Carr Co., United Can Div. of TRW Cambridge, Massachusetts	89536 John Fluke Mfg. Co., Inc. Seattle, Washington
75042 TRW Electronics Components IRC Fixed Resistors Philadelphia, Pennsylvania	80294 Bourns Inc., Instrument Div. Riverside, California	83298 Bendix Corp. Electric Power Div. Eatontown, New Jersey	89730 G.E. Co., Newark Lamp Works Newark, New Jersey
75376 Kurz-Kasch Inc. Dayton, Ohio		83330 Herman H. Smith, Inc. Brooklyn, New York	
75378 CTS Knights Inc. Sandwich, Illinois		83478 Rubbercraft Corp. of America, Inc. West Haven, Connecticut	

Federal Supply Codes for Manufacturers (cont)

90201 Mallory Capacitor Co. Div. of P.R. Mallory Co., Inc. Indianapolis, Indiana	91836 King's Electronics Co., Inc. Tuckahoe, New York	95354 Methode Mfg. Corp. Rolling Meadows, Illinois	98291 Seaelectro Corp. Mamaroneck, New York
90211 Use 56365 Square D Co. Chicago, Illinois	91929 Honeywell Inc. Micro Switch Div. Freeport, Illinois	95712 Bendix Corp. Electrical Components Div. Microwave Devices Plant Franklin, Indiana	98388 Royal Industries Products Div. San Diego, California
90215 Best Stamp & Mfg. Co. Kansas City, Missouri	91934 Miller Electric Co., Inc. Div. of Aunet Woonsocket, Rhode Island	95987 Weckesser Co. Inc. Chicago, Illinois	98743 Replaced by 12749
90303 Mallory Battery Co. Div. of Mallory Co., Inc. Tarrytown, New York	92194 Alpha Wire Corp. Elizabeth, New Jersey	96733 San Fernando Electric Mfg. Co. San Fernando, California	98925 Replaced by 14433
91094 Essex International Inc. Suglex/IWP Div. Newmarket, New Hampshire	93332 Sylvania Electric Products Semiconductor Products Div. Woburn, Massachusetts	96853 Gulton Industries Inc. Measurement and Controls Div. formerly Rustrak Instruments Co. Manchester, New Hampshire	99120 Plastic Capacitors, Inc. Chicago, Illinois
91293 Johanson Mfg. Co. Boonton, New Jersey	94145 Replaced by 49956	96881 Thomson Industries, Inc. Manhasset, New York	99217 Bell Industries Elect. Comp. Div. formerly Southern Elect. Div. Burbank, California
91407 Replaced by 58474	94154 Use 94988 Wagner Electric Corp. Tung-Sol Div. Newark, New Jersey	97540 Master Mobile Mounts, Div. of Whitehall Electronics Corp. Ft. Meyers, Florida	99392 STM Oakland, California
91502 Associated Machine Santa Clara, California	94222 Southco Inc. formerly South Chester Corp. Lester, Pennsylvania	97913 Industrial Electronic Hardware Corp. New York, New York	99515 ITT Jennings Monrovia Plant Div. of ITT Jennings formerly Marshall Industries Capacitor Div. Monrovia, California
91506 Augat Inc. Attleboro, Massachusetts	95146 Alco Electronic Products Inc. Lawrence, Massachusetts	97945 Penwalt Corp. SS White Industrial Products Div. Piscataway, New Jersey	99779 Use 29587 Bunker-Ramo Corp. Barnes Div. Landsdowne, Pennsylvania
91637 Dale Electronics Inc. Columbus, Nebraska	95263 Leecraft Mfg. Co. Long Island City, New York	97966 Replaced by 11358	99800 American Precision Industries Inc. Delevan Division East Aurora, New York
91662 Elco Corp. Willow Grove, Pennsylvania	95264 Replaced by 98278	98094 Replaced by 49956	99942 Centrelab Semiconductor Centrelab Electronics Div. of Globe-Union Inc. El Monte, California
91737 Use 71468 Gremar Mfg. Co., Inc. ITT Cannon/Gremar Santa Ana, California	95275 Vitramon Inc. Bridgeport, Connecticut	98159 Rubber-Teck, Inc. Gardena, California	Toyo Electronics (R-Ohm Corp.) Irvine, California
91802 Industrial Devices, Inc. Edgewater, New Jersey	95303 RCA Corp. Receiving Tube Div. Cincinnati, Ohio	98278 Malco A Microdot Co., Inc. Connector & Cable Div. Pasadena, California	National Connector Minneapolis, Minnesota
91833 Keystone Electronics Corp. New York, New York	95348 Gordo's Corp. Bloomfield, New Jersey		

U.S. SALES AREAS

AK, Anchorage

Harry Lang & Associates
1371 Hillcrest Drive #303
Anchorage, AK 99503
(907) 279-5741

AL, Huntsville

John Fluke Mfg. Co., Inc.
3322 S. Memorial Parkway
Suite 96
Huntsville, AL 35801
(205) 881-6220
(404) 396-3224 (Atlanta)

AZ, Tempe

John Fluke Mfg. Co., Inc.
2125 S. 48th Street
Suite 104
Tempe, AZ 85282
(602) 967-8724
(602) 790-9881 (Tucson)

CA, Los Angeles

John Fluke Mfg. Co., Inc.
20902 South Bonita St.
Carson, CA 90746
(213) 538-3900 or
(714) 761-2449

CA, Santa Clara

John Fluke Mfg. Co., Inc.
2300 Walsh Ave., Bldg. K
Santa Clara, CA 95051
(408) 727-0513

CA, Tustin

John Fluke Mfg. Co., Inc.
15445 Red Hill Ave., Suite F
Tustin, CA 92680
(714) 838-8863
(714) 226-1254 (San Diego)

CO, Denver

John Fluke Mfg. Co., Inc.
1980 South Quebec St. #4
Denver, CO 80231
(303) 750-1222

CT, Hartford

John Fluke Mfg. Co., Inc.
124 Hebron Ave.
Glastonbury, CT 06033
(203) 633-0777

FL, Orlando

John Fluke Mfg. Co., Inc.
940 N. Fern Creek Ave.
Orlando, FL 32803
(305) 896-4881

GA, Atlanta

(404) 396-3224

HI, Honolulu

EMC Corporation
2979 Ualena St.
Honolulu, HI 96819
(808) 836-1138

IA, Iowa City

(319) 354-2811

IL, Chicago

John Fluke Mfg. Co., Inc.
1400 Hicks Road
Rolling Meadows, IL 60008
(312) 398-0850

IN, Indianapolis

John Fluke Mfg. Co., Inc.
5610 Crawfordsville Rd.
Corporate Square West
Suite 802
Indianapolis, IN 46224
(317) 244-2456

KA, Kansas City

John Fluke Mfg. Co., Inc.
4550 West 109th St.
Suite 130
Shawnee Mission, KA 66211
(913) 381-9800

LA, New Orleans

(504) 455-0814

MA, Burlington

John Fluke Mfg. Co., Inc.
25 "B" Street
Burlington, MA 01803
(617) 273-4674

MD, Rockville

John Fluke Mfg. Co., Inc.
5640 Fishers Lane
Rockville, MD 20852
(301) 770-1570
(301) 792-7060 (Baltimore)

MI, Detroit

John Fluke Mfg. Co., Inc.
13955 Farmington Rd.
Livonia, MI 48154
(313) 522-9140

MN, Minneapolis

John Fluke Mfg. Co., Inc.
7373 West 147th St.
Suite 196
Apple Valley, MN 55124
(612) 432-9400

MO, St. Louis

John Fluke Mfg. Co., Inc.
300 Brookes Dr., Suite 100
Hazelwood, MO 63042
(314) 731-3388

NC, Greensboro

John Fluke Mfg. Co., Inc.
1310 Beaman Place
Greensboro, NC 27408
(919) 273-1918

NJ, Paramus

John Fluke Mfg. Co., Inc.
P.O. Box 930
West 75 Century Road
Paramus, NJ 07652
(201) 262-9550

NM, Albuquerque

John Fluke Mfg. Co., Inc.
1108 Alvarado Drive N.E.
Albuquerque, NM 87110
(505) 265-8431

NY, Rochester

John Fluke Mfg. Co., Inc.
4515 Culver Road
Rochester, NY 14622
(716) 266-1400

OH, Cleveland

John Fluke Mfg. Co., Inc.
7830 Freeway Circle
Middleburg Heights, OH 44130
(216) 234-4540

OH, Dayton

John Fluke Mfg. Co., Inc.
4756 Fishburg Rd.
Dayton, OH 45424
(513) 233-2238
(614) 889-5715 (Columbus)

OR, Portland

John Fluke Mfg. Co., Inc.
18360 S.W. Springfield Lane
Aloha, OR 97007
(503) 642-1342

PA, Philadelphia

John Fluke Mfg. Co., Inc.
1010 West 8th Ave., Suite H
King of Prussia, PA 19406
(215) 265-4040
(412) 261-5171 (Pittsburgh)

TX, Austin

John Fluke Mfg. Co., Inc.
Creek Gardens, Suite 103
8705 Shoal Creek Blvd.
Austin, TX 78758
(512) 459-3344

TX, Dallas

John Fluke Mfg. Co., Inc.
14400 Midway Road
Dallas, TX 75234
(214) 233-9990

TX, Houston

John Fluke Mfg. Co., Inc.
4240 Blue Bonnet Dr.
Stafford, TX 77477
(713) 491-5995
(504) 455-0814 (New Orleans)

UT, Salt Lake City

John Fluke Mfg. Co., Inc.
5226 So. 300 West, Suite #2
Salt Lake City, UT 84107
(801) 268-9331

WA, Seattle

John Fluke Mfg. Co., Inc.
975 Industry Drive
Seattle, WA 98188
(206) 575-3765

For more information on Fluke products or Sales Offices you may dial (800) 426-0361 toll-free in most of U.S.
From Alaska, Hawaii, or Washington phone (206) 356-5400. From other countries phone (206) 356-5500.

INTERNATIONAL SALES OFFICES

Argentina •

Coasin, S.A.
Virrey del Pino 4071
Buenos Aires, Argentina
Tel: 5523185, TLX: 390122284

Australia •

Elmeasco Instruments Pty Ltd.
P.O. Box 30, Concord, N.S.W.
Australia 2137
Tel: (2) 736-2888, TLX: AA25887
Elmeasco Instruments Pty Ltd.
P.O. Box 107
Mt. Waverly, VIC. 3149
Australia
Tel: 233-4044
TLX: 36206 (ELMVIC)

Elmeasco Instruments Pty Ltd.
Professional Suite's Bldg.
G.P.O. Box 2360
Brisbane, 4001, Australia
Tel: (07) 229-3161

Elmeasco Instruments Pty Ltd.
P.O. Box 1240
G.P.O. Adelaide 5001
South Australia
Elmeasco Instruments Pty. Ltd.
P.O. Box 95, Gosnells
West Australia 6110
Tel: (09) 348-3362

Austria ■

Walter Rekersch
Elektronische Gerate GmbH & Co.
Vertrieb-KG., Obachgasse 28
A-1220 Vienna, Austria
Tel: (0222) 235555, TLX: 134759

Bahrain ■

AL-Hamidiya
P.O. Box 20074
Manama, Bahrain
Tel: 259958, TLX: 8895

Bangladesh •

Motherland Corporation
24 Hatkhola Rd., Tikatuli
Dacca 3, Bangladesh
Tel: 257249, 255776

Belgium ■

Fluke (Belgium) S.A./N.V.
6, Rue de Geneve
1140 Brussels, Belgium
Tel: (2) 2164090, TLX: 26312

Bolivia •

Coasin Bolivia S.R.L.
Casilla 7295, La Paz, Bolivia
Tel: 40962, TLX: 5255

Brazil •

Fluke Brasil-Industria E
Comercio LTDA
Al. Amazonas 422,
AlphaVille, Barueri,
CEP 06400 Sao Paulo, Brazil
Tel: (011) 421-3603

Brunei •

Rank O'Connor's (PTE) Limited
No. 8, BK.D
Surfri Shop House Complex
Mile 1, Jalong Tutong
Bandar Seri Begawan, Brunei
Tel: 26680

Bulgaria ■

Amtest Associates Ltd.
P.O. Box 55
Addlestone, Surrey KT15 1DU
United Kingdom
Tel: Weybridge (932) 52121
TLX: 928855

Canada •

Allan Crawford Assoc., Ltd.
#14 1935 30th Ave. N.E.
Calgary, Alberta T2E 6Z5
Tel: (403) 230-1341, TLX: 03-821186

Allan Crawford Assoc., Ltd.
Suite 1, Box 60
Edmonton, Alberta T5L 4H8
Tel: (403) 451-4893

Allan Crawford Assoc., Ltd.
3795 William Street
Burnaby, British Columbia V5C 3H3
Tel: (604) 294-1326, TLX: 04-54247

Allan Crawford Assoc., Ltd.
192 Joseph Zatzman Dr.
Suite 4

Burnside Industrial Park
Dartmouth, Nova Scotia B3B 1N4
Tel: (902) 463-8640, TLX: 01931604

Allan Crawford Assoc., Ltd.
881 Lady Ellen Place
Ottawa, Ontario K1Z 5L3
Tel: (613) 722-7682, TLX: 0533600

Allan Crawford Assoc., Ltd.
6503 Northam Drive
Mississauga, Ontario L4V 1J5
Tel: (416) 678-1500, TLX: 06968769

Allan Crawford Assoc., Ltd.
7918 cote de Liesse
St. Laurent, Quebec H4T 1E7
Tel: (514) 731-8564, TLX: 05824944

Chad ■

Fluke (Holland) B.V.
P.O. Box 5053, 5004 EB Tilburg
Zevenheuvelenweg 53, 5048 AN Tilburg
The Netherlands
Tel: (013) 673973, TLX: 52237

Chile •

Intronica Chile Ltda.
Manuel Montt 024 - Of. D
Casilla 16228, Santiago 9, Chile
Tel: 44940
TLX: No 40301 Cab. Publ.,
Attn: Intronica Chile

China, People's Republic of •

Fluke International Corporation
P.O. Box C9090
Everett, WA 98206, U.S.A.
Tel: (206) 356-5511
TLX: 152662 JOHN FLUKE EVT

Colombia •

Sistemas E Instrumentacion, Ltda.
Carrera 13, No. 37-43, Of. 401
Ap. Aereo 29583
Bogota DE, Colombia SA
Tel: 232-45-32, TLX: 45787

Cyprus ■

Chris Radiovision Ltd.
P.O. Box 1989, Nicosia, Cyprus
Tel: 66121, TLX: 3495

Czechoslovakia ■

Amtest Associates Ltd.
P.O. Box 55
Addlestone, Surrey KT15 1DU
United Kingdom
Tel: Weybridge (932) 52121
TLX: 928855

Denmark ■

Tage Olsen A/S
Ballerup Byvej 222
DK - 2750 Ballerup, Denmark
Tel: (2) 658111, TLX: 35293

Ecuador •

Proteco Coasin Cia., Ltda.
Edificio "Jerico"
Ave. 12 de Octubre #2285 y
Ave. Orellana (Planta Baja)
Quito, Ecuador
Tel: 529684, TLX: 2865 Protec Ed

Proteco Coasin Cia., Ltda.
Calderon 103Y Malecon
Casilla #9733
Guayaquil, Ecuador
Tel: 526093

Egypt and Sudan ■

Electronic Engineering Liaison Office
P.O. Box 2891 Horreya
11 Ahmed Khashara St.
Hegas Square
Heliopolis, Cairo, Egypt
Tel: 691588, TLX: 92502

Ethiopia ■

Fluke (Holland) B.V.
P.O. Box 5053, 5004 EB Tilburg
Zevenheuvelenweg 53, 5048 AN Tilburg
The Netherlands
Tel: (013) 673973, TLX: 52237

Fiji •

AWA Fiji
P.O. Box 858
47 Forster Road, Walu Bay
Suva, Fiji
Tel: 312079, TLX: FJ2347

Finland ■

Oy Findip AB, Teollisuustie 7
02700 Kauniainen, Finland
Puh: (0) 5052255
TLX: 123129

France ■

M.B. Electronique S.A.
Rue Fourny 606, Z1 Centre
78530 BUC
B.P. No. 31
78530 BUC, France
Tel: (3) 9568131, TLX: 695414

German Democratic Republic ■

Amtest Associates Ltd.
P.O. Box 55
Addlestone, Surrey KT15 1DU
United Kingdom
Tel: Weybridge (932) 52121
TLX: 928855

German Federal Republic ■

Fluke (Deutschland) GmbH
Max-Hueber StraBe 8
8045 Ismaning, West Germany
Tel: (089) 96251, TLX: 522472
Rapifax: (089) 966718
Fluke (Deutschland) GmbH
Meineckestrasse 53
4000 Dusseldorf 30, West Germany
Tel: (0211) 450831, TLX: 8585576

Fluke (Deutschland) GmbH
Oberer Kirchhaldenweg 135
7000 Stuttgart 1, West Germany
Tel: (0711) 694091, TLX: 722518

Fluke (Deutschland) GmbH
Hubertusallee 46
1000 Berlin-33, West Germany
Tel: (030) 8911090
TLX: 0184978

Greece ■

Hellenic Scientific Representations Ltd.
11, Vrasside Street
Athens 612, Greece
Tel: (1) 711140, TLX: 219330

Hong Kong •

Schmidt & Co. (H.K.) Ltd.
28th Fl. Wing on Centre
111 Connaught Road
Central Hong Kong
Tel: 5-455644
TLX: 74766 SCHMC HX

Hungary ■

Amtest Associates Ltd.
P.O. Box 55
Addlestone, Surrey KT15 1DU
United Kingdom
Tel: Weybridge (932) 52121
TLX: 928855

Iceland •

Kristjan O. Skagfjord Ltd.
P.O. Box 906
Reykjavik, Iceland
Tel: 24120, TLX: 2133

India •

Hinditron Services Pvt. Ltd.
69/A.L. Jagmohandas Marg
Bombay 400 006, India
Tel: 811316,
TLX: 112326 Hspl In

Hinditron Services Pvt. Ltd.
33/44-A 8th Main Road
Raj Mahl Vilas Extension
Bangalore 560 080, India
Tel: 33139
TLX: 0845741

Hinditron Services Pvt. Ltd.
Shantiniketan, Office No.6
6th Floor, 8 Camac Street
Calcutta 700 017, India
Tel: 434032, 447541

Hinditron Services Pvt. Ltd.
15 Community Centre, Panchshila Park
New Delhi 110 017, India
Tel: 653397

Hinditron Services Pvt. Ltd.
Srinath Complex, 5th Floor
1-1-58/1 to 1-1-58/11
Sarojini Devi Road
Secunderabad 500 003, India
Tel: 61705

Indonesia •

P.T. Dwi Tunggal Jaya Sakti
Sangga Buana Bldg., 1st Floor
Jl. Senen Raya 44, P.O. Box 4435
Jakarta, Indonesia
Tel: 367390-9, TLX: 46624

Iran ■

Fluke (Holland) B.V.
P.O. Box 5053, 5004 EB Tilburg
Zevenheuvelenweg 53, 5048 AN Tilburg
The Netherlands
Tel: (013) 673973, TLX: 52237

Iraq ■

Fluke (Holland) B.V.
P.O. Box 5053, 5004 EB Tilburg
Zevenheuvelenweg 53, 5048 AN Tilburg
The Netherlands
Tel: (013) 673973, TLX: 52237

Ireland ■

Euro Electronics
32 Brews Hill
Naven County Meath, Ireland
Tel: (46) 23577, TLX: 3182

Israel ■

R.D.T. Electronics Engineering Ltd.
P.O. Box 75
46, Sokolov Street
Ramat Hasharon 47235, Israel
Tel: (3) 483216, TLX: 32143



Italy ■

Sistrel S.p.A.
Via Giuseppe Armellini No. 37
00143 Rome, Italy
Tel: (6) 5915551, TLX: 68356

Sistrel S.p.A.
Via Pelizza da Volpedo 59
20092 Cinisello besamo
Milan, Italy
Tel: (2) 6181893, TLX: 334643

Sistrel S.p.A.
Via Cintia Parco S. Paolo 35
80126 Naples, Italy
Tel: (81) 7679700

Japan ■

John Fluke Mfg. Co., Inc.
Japan Branch
(PC Board Testers only)
1 Higashikata-machi
Midori-ku

Yokohama 226, Japan
Tel: (045) 473-5425
TLX: 3823-666 FLKJJP

Tokyo Electron Ltd.
38 FL Shinjuku Nomura Bldg.
1-26-2, Nishi-Shinjuku
Shinjuku-ku

Tokyo 160, Japan
Tel: 03-343-4411, TLX: 2322220

Kenya ■

ADCOM Ltd.
P.O. Box 30070
Nairobi, Kenya, East Africa
Tel: 331955, TLX: 22639

Korea ■

Electro-Science Korea Co.
C.P.O. Box 8446
Room 201, Boondo Bldg.
56-12 Jangchung-Ika
Jung-ku
Seoul, Korea
Tel: 261-7702, TLX: K25381

Kuwait ■

Tareq Company
P.O. Box Safat 20506
Kuwait, Arabian Gulf
Tel: 436100/436045
TLX: 2315

Lebanon and Jordan ■

Mabek (Electronic Division)
P.O. Box 13-5657
Beirut, Lebanon
Tel: 812523/812538
TLX: 22889

Libya ■

Fluke (Holland) B.V.
P.O. Box 5053, 5004 EB Tilburg
Zevenheuvelenweg 53, 5048 AN Tilburg
The Netherlands
Tel: (013) 673973, TLX: 52237

Malaysia ■

Rank O'Connor's (PTE) Limited
P.O. Box 91, Petaling Jaya
Selangor, West Malaysia
Tel: 566599
TLX: OCONOR MA37649

Rank O'Connor's (PTE) Limited
Lot No. 5 Taman Mesra
Mile 3, Jalan Penampang
Kota Kinabalu, East Malaysia
Tel: 55322, TLX: MA80286

Mexico ■

Christensen S.A.
Guillermo Prieto 76-304
Col. San Rafael
Delegacion Cuahutemoc
06470—Mexico, D.F.
Tel: 546-25-95/546-29-55
TLX: 017-75612

Morocco ■

Mainvest
Residence Moulay Ismail, Bat. C.
12, Place des Alaouites
Rabat, Morocco
Tel: (7) 23990, TLX: 31036

Nepal ■

Associated Enterprises
GPO Box 790, Pyaphal Tole
Kathmandu, Nepal
Tel: 13868

Netherlands ■

Fluke (Nederland) B.V.
Zonnebaan 39
3606 CH Maarssen, The Netherlands
P.O. Box 225
3600 AE Maarssen, The Netherlands
Tel: (030) 436514, TLX: 47128

New Zealand ■

McLean Information Technology
P.O. Box 18-065, Glen Innes
Auckland, New Zealand
Tel: 587-037, TLX: NZ 2763
W & K McLean Ltd.
P.O. Box 496
Wellington, New Zealand
Tel: 851-450

Nigeria ■

Mofat Engineering Co., Ltd.
P.O. Box 6369
Lagos, Nigeria
Tel: 960744, TLX: 20202

Norway ■

Morgenstjerne & Co A/S
Konghellegate 3
P.O. Box 6688, Rodelokka
Oslo 5, Norway
Tel: (2) 356110, TLX: 71719

Pakistan ■

Pak International Operations
505 Muhammadi House
I.I. Chundrigar Road
P.O. Box 5323, Karachi, Pakistan
Tel: 221127, TLX: 24494

PDR Yemen ■

Fluke (Holland) B.V.
P.O. Box 5053, 5004 EB Tilburg
Zevenheuvelenweg 53, 5048 AN Tilburg
The Netherlands
Tel: (013) 673973, TLX: 52237

Peru ■

Importaciones Y Representaciones
Electronicas S.A.
Avda. Franklin D. Roosevelt 105
Lima 1, Peru
Tel: 288650, TLX: 37425663

Philippines ■

Spark Radio & Electric Supply
P.O. Box 610, Greenhills, San Juan
M. Manila, Philippines
Tel: 78-78-16
TLX: 27901 RLA PH

Poland ■

Amtest Associates Ltd.
P.O. Box 55
Addlestone, Surrey KT15 1DU
United Kingdom
Tel: Weybridge (932) 52121
TLX: 928855

Portugal ■

Decada-Equipamentos de
Electronica, Lda.
Rue Pedro Nunes, 47-C
1000 Lisboa
P.O. Box 1128, 1003 Lisboa Codex
Tel: (19) 574984, TLX: 18469

Qatar ■

Technology Organisation
P.O. Box 5549, Doha, Qatar
Tel: 321431, TLX: 4581

Romania ■

Amtest Associates Ltd.
P.O. Box 55
Addlestone, Surrey KT15 1DU
United Kingdom
Tel: Weybridge (932) 52121
TLX: 928855

Saudi Arabia ■

Electronic Equipment Marketing Co. Ltd.
P.O. Box 3750
Riyadh, Saudi Arabia
Tel: (1) 4032761, TLX: 201120

Singapore ■

Rank O'Connor's (PTE) Limited
98 Pasir Panjang Road
Singapore 0511
Republic of Singapore
Tel: 637944
TLX: OCONSIN RS21023

Somalia ■

Fluke (Holland) B.V.
P.O. Box 5053, 5004 EB Tilburg
Zevenheuvelenweg 53, 5048 AN Tilburg
The Netherlands
Tel: (013) 673973, TLX: 52237

South Africa ■

Fluke S.A. (Pty) Ltd.
P.O. Box 39797, Bramley 2018
Republic of South Africa
Tel: (011) 786-3170, TLX: 424328

Spain ■

Hispano Electronica S.A.
Poligono Industrial Urtinsa
Apartado de Correos 48
Alcorcon (Madrid), Spain
Tel: (1) 6194108
TLX: 22404/42634

Sri Lanka ■

Jay-Es Electronics
160 Poorvarama Mawatha
Colombo 5, Sri Lanka
Tel: 073-2393

Sweden ■

Teletinstrument AB
P.O. Box 4490
162 04 Vallingby, Sweden
Tel: (8) 380370, TLX: 11347

Switzerland ■

Traco Electronic AG
Jenatschstrasse 1
8002 Zurich, Switzerland
Tel: (1) 2010711, TLX: 54318

Syria ■

Mabek (Electronic Division)
P.O. Box 4238
Damascus, Syria

Taiwan ■

Schmidt Scientific Far East Ltd.
906, Chia Hsin Bldg.
96, Chung Shan N. Rd., Sec. 2
Taipei, Taiwan,
Tel: 5817393/5814976
TLX: 11111

Thailand ■

Measuretronix Ltd.
1899/10 Ramkamhaeng Rd.
Huamark, Bangkok, Thailand
Tel: 3143369, TLX: 81143

Tunisia ■

Selep S.A.R.L.
6, Rue de Sparte
Tunis - 1000 RP, Tunisia
Tel: (1) 248093, TLX: 13030

Turkey ■

Erkman Elektronik Aletler
Ticaret Anonim Sirketi
Necatibey Cad 92/3
Karakoy, Istanbul, Turkey
Tel: (1) 5461
TLX: 23353

United Arab Emirates ■

Al-Sanani Ge. Trad. Est.
P.O. Box 7187
Abu-Dhabi, United Arab Emirates
Tel: 828428/821370/821371/
TLX: 23966

United Kingdom ■

Fluke (Great Britain) Ltd.
Colonial Way
Watford, Herts, WD2 4TT
United Kingdom
Tel: (0923) 40511, TLX: 934583
Rapifax: (0923) 25067

Uruguay ■

Coasin Uruguaya S.R.L.
Cuareim 2196
Casilla de Correos 1400
Correo Central
Montevideo, Uruguay
Tel: 29-31-95, TLX: UY5671

U.S.S.R. ■

Amtest Associates Ltd.
P.O. Box 55
Addlestone, Surrey KT15 1DU
United Kingdom
Tel: Weybridge (932) 52121
TLX: 928855

Venezuela ■

Coasin, C.A.
Calle 9 Con Calle 4, Edif. Edinurbi
Piso 3, La Urbina
Apartado De Correos
NR-70.136 Los Ruices
Caracas 1070A, Venezuela
Tel: 38-78-42, TLX: 21027 Emven VE

Yemen ■

Fluke (Holland) B.V.
P.O. Box 5053, 5004 EB Tilburg
Zevenheuvelenweg 53, 5048 AN Tilburg
The Netherlands
Tel: (013) 673973, TLX: 52237

Yugoslavia ■

Amtest Associates Ltd.
P.O. Box 55
Addlestone, Surrey KT 15 1DU
United Kingdom
Tel: Weybridge (932) 52121
TLX: 928855

■ Supplied and Supported by —

Fluke (Holland) B.V.
P.O. Box 5053, Zevenheuvelenweg 53
5004 EB Tilburg, Netherlands
Tel: (013) 673973, TLX: 52237

● Supplied and Supported by —

Fluke International Corporation
P.O. Box C9090
Everett, WA 98206 U.S.A.
Tel: (206) 356-5500
TLX: 152662 JOHN FLUKE EVT

TECHNICAL SERVICE CENTERS

U.S. & Canada

CA, Burbank

Fluke Technical Center
2020 N. Lincoln Street
Burbank, CA 91504
(213) 849-4641

CA, Santa Clara

Fluke Technical Center
2300 Walsh Ave., Bldg. K
Santa Clara, CA 95050
(408) 727-8121

CO, Denver

Fluke Technical Center
1980 S. Quebec St., Unit 4
Denver, CO 80231
(303) 750-1228

FL, Orlando

Fluke Technical Center
940 N. Fern Creek Avenue
Orlando, FL 32803
(305) 896-2296

IL, Rolling Meadows

Fluke Technical Center
1400 Hicks Road
Rolling Meadows, IL 60008
(312) 398-5800

MA, Burlington

Fluke Technical Center
25 "B" Street
Burlington, MA 01803
(617) 273-4678

MD, Rockville

Fluke Technical Center
5640 Fishers Lane
Rockville, MD 20852
(301) 770-1576

NJ, Paramus

Fluke Technical Center
West 75th Century Road
Paramus, NJ 07652
(201) 262-9550

TX, Dallas

Fluke Technical Center
14400 Midway Road
Dallas, TX 75240
(214) 233-9945

WA, Everett

Fluke Technical Center
6920 Seaway Blvd.
Everett, WA 98206
(206) 356-5560

ALB, Calgary

Allan Crawford Assoc., Ltd.
#14 1935 30th Ave. N.E.
Calgary, Alberta T2E 6Z5
(403) 230-1341

ONT, Mississauga

Allan Crawford Assoc., Ltd.
6503 Northam Drive
Mississauga, Ontario L4V 1J2
(416) 678-1500

QUE, Montreal

Allan Crawford Assoc., Ltd.
7018 Cote de Liesse
Montreal, Quebec H4T 1E7
(514) 731-8564

B.C., Burnaby

Allan Crawford Assoc. Ltd.
3795 William St.
Burnaby, B.C. V5C 3H3
(604) 294-1326

Other Areas

Argentina

Coasin S.A.
Virrey del Pino 4071
Buenos Aires, Argentina
Tel: 522-5248

Australia

Elmeasco Instruments Pty Ltd.
P.O. Box 30
Concord, N.S.W.
Australia 2137
Tel: (02) 736-2888

Australia

Elmeasco Instruments Pty. Ltd.
P.O. Box 107
Mr. Waverly, VIC 3149
Australia
Tel: (03) 2334044

Australia

Elmeasco Instruments Pty. Ltd.
GPO Box 2360
Brisbane, Queensland 4001
Australia
Tel: (07) 229-3161

Austria

Walter Rekersch
Elektronische Gerate GmbH & Co.
Vertriebs-KG., Obachgasse 28
A-1220 Vienna, Austria
Tel: (0222) 235555

Belgium

Fluke (Belgium) S.A./N.V.
6, Rue de Geneve
1140 Brussels, Belgium
Tel: 09-32-2-2164090

Brazil

Fluke Brasil-Industria e Comercio Ltda.
Al. Amazonas 422, Alphaville, Barueri
CEP 06400 Sao Paulo, Brazil
Tel: (011) 421-3603

Chile

Intronica Chile Ltda.
Casilla 16228
Santiago 9, Chile
Tel: 44940

China, Peoples Republic of

Beijing Radio Research Institute
Dianmen East Avenue 89
Beijing, China
Tel: 445612

Colombia

Sistemas E Instrumentacion, Ltda.
Carrera 13, No. 37-43, Of. 401
Ap. Aero 29583
Bogota DE, Colombia S.A.
Tel: 232-45-32

Denmark

Tage Olson A/S
Ballerup Byvej 222
DK-2750 Ballerup
Denmark
Tel: 09-45-2-658111

Ecuador

Proteco Coasin Cia., Ltda.
Edificio "Jerico"
Ave. 12 de Octubre #2285 y
Ave. Orellana (Planta Baja)
Quito, Ecuador
Tel: 526759

Egypt and Sudan

Electronic Engineering Liaison Office
11 Ahmed Khashaba Street
Hegas Square
Heliopolis, Cairo, Egypt
Tel: 691588

Finland

Oy Findip AB
Teollisuustie 7
02700 Kauniainen
Finland
Tel: 09-358-0-502255

France

M.B. Electronique S.A.
Rue Fourny
ZAC de BUC
B.P. No. 31
78530 BUC, France
Tel: 09-33-1-9568131

Greece

Hellenic Scientific
Representations Ltd.
11, Vrassida Street
Athens 612, Greece
Tel: 09-30-1-711140

Hong Kong

Schmidt & Co (H.K.) Ltd.
28th Fl. Wing On Centre
111 Connaught Road
Central Hong Kong
Tel: 5-455644

India

Hinditron Services Pvt. Ltd.
Field Service Centre
8th Main Road
33/44-A Raj Mahal Vilas Extn.
Bangalore 560 080, India
Tel: 33139

India

Hinditron Services Pvt. Ltd.
69/A.L. Jagmohandas Marg
Bombay 400 006, India
Tel: 811316

India

Hinditron Services Pvt. Ltd.
15, Community Centre
Panchshila Park
New Delhi, India 110-017
Tel: 619118

Israel

R.D.T. Electronics Engineering Ltd.
P.O. Box 75
46, Sokolov Street
Ramat Hasharon 47235
Israel
Tel: 09-972-3-483211

Italy

Sistrel S.p.A.
Via Pelizza da Volpedo 59
20092 Cinisello Besamo
Milan, Italy
Tel: (2) 6181893

Italy

Sistrel S.p.A.
Via Giuseppe Armellini No. 37
00143 Rome, Italy
Tel: 09-39-6-5915551

Japan

John Fluke Mfg. Co., Inc.
Japan Branch
1 Higashikata-machi
Midori-ku
Yokohama 226, Japan
Tel: (045) 473-5428

Korea

Electro-Science Korea Co.
C.P.O. Box 8446
Room 201, Boondo Bldg.
56-12, Gangchung-1 Ka
Gung-Ku
Seoul, Korea
Tel: 261-7702

Malaysia

Rank O'Connor's (Malaysia) SDN. BHD.
P.O. Box 91
Petaling Jaya, Selangor
West Malaysia
Tel: 566599

Mexico

Christensen S.A.
Guillermo Prieto 76-304
Col. San Rafael
Delegacion Cuahutemoc
06470-Mexico, D.F.
Tel: 546-25-95

Netherlands

Fluke (Nederland) B.V.
Zonnebaan 39
3606 CH Maarssen, The Netherlands
P.O. Box 225
3600 AE Maarssen, The Netherlands
Tel: (030) 436514

New Zealand

McLean Information Technology Ltd.
P.O. Box 18065
Glen Innes
Auckland 6, New Zealand
Tel: 587-037

Norway

Morgenstjerne & Co. A/S
Konghellegate 3
P.O. Box 6688, Rodelokka
Oslo 5, Norway
Tel: 09-47-2-356110

Pakistan

Pak International Operations
505 Muhammadi House
I.I. Chundrigar Road
P.O. Box 5323
Karachi-2 Pakistan
Tel: 221127/239052

Peru

Importaciones Y Representaciones
Electronicas S.A.
Avda. Franklin D. Roosevelt 105
Lima 1, Peru
Tel: 288650

Philippines

Spark Radio and Electronics Corp.
P.O. Box 610 Greenhills
Metro Manila, Philippines 3113
Tel: 78-78-16

Portugal

Equipamentos de Laboratorio, Ltda.
P.O. Box 1128
Lisbon 1000, Portugal
Tel: 09-351-19-574984

Republic of Singapore

Rank O'Connor's (PTE) Ltd.
98 Pasir Panjang Road
Singapore 0511
Republic of Singapore
Tel: 637944

Republic of South Africa

Fluke S.A. (Pty) Ltd.
P.O. Box 39797
Bramley 2018
Republic of South Africa
Tel: (011) 786-3170

Spain

Hispano Electronics S.A.
Apartado de Correos 48
Alcorcon (Madrid)
Spain
Tel: 09-34-1-6194108

Sweden

Teleinstrument AB
P.O. Box 4490
S-162 04 Vallingby 4
Sweden
Tel: -09-46-8-380370

Switzerland

Traco Electronic AG
Jenatschstrasse 1
8002 Zurich
Switzerland
Tel: 09-41-1-2010711



John Fluke Mfg. Co., Inc., P.O. Box C9090, Everett, WA 98206. Phone (206) 342-6300
Fluke (Holland) B.V., P.O. Box 5053, 5004 EB, Tilburg, The Netherlands. Phone (013) 673973

Litho in U.S.A.: 12/81

Appendix 7A

Manual Change Information

INTRODUCTION

This appendix contains information necessary to backdate the manual to conform with earlier pcb configurations. To identify the configuration of the pcb's used in your instrument, refer to the revision letter (marked in ink) on the component side of each pcb assembly. Table 7A-1 defines the assembly revision levels documented in this manual.

NEWER INSTRUMENTS

As changes and improvements are made to the instrument, they are identified by incrementing the revision letter marked on the affected pcb assembly. These changes are documented on a supplemental change/errata sheet which, when applicable, is inserted at the front of the manual.

OLDER INSTRUMENTS

To backdate this manual to conform with earlier assembly revision levels, perform the changes indicated in Table 7A-1.

CHANGES

The following design changes, unless otherwise noted, affect only Section 5 and Section 8 of this manual:

- Section 5, parts list and component location drawings
- Section 8, schematics and component location drawings

The material affected within these sections is easily determined by the type of change. See Table 7A-2.

CHANGE #1

Main Assembly - REV. D3 (15221)

Change R10

FROM: RES, COMP, 100+/-5%,1/2W/168508/01121/EB1015

TO: RES, DEP CAR, 470+/-5%,1/4W/573121/80031/CR251-4-5P470E

Change U30

FROM: IC, TTL HEX INVERTER/407593/01295/SN7406N

TO: IC, TTL HEX INVERTER/381848/02735/CD4049

On this revision of the Main Assembly, resistor network U63 is located atop U62.

Relocate R10 from the output of U30 to the input as shown in the following partial schematic.

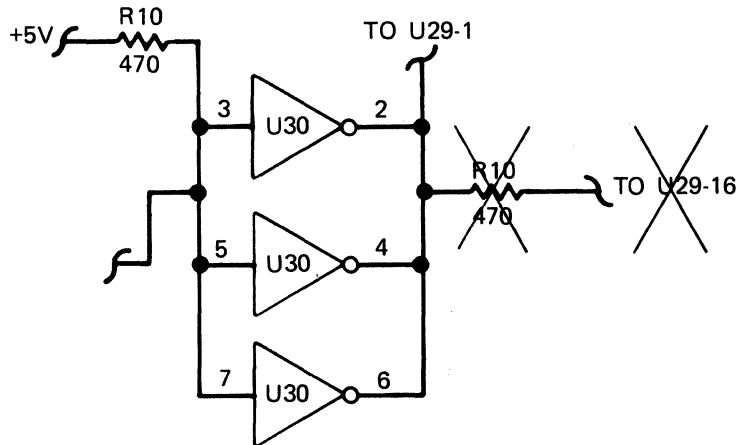

Main Assembly - REV. D2 (15303)

Make the REV. D3 changes plus the following changes.

Change R43

FROM: RES, DEP CAR, 680 +/-5%,1/4W/573154/80031/CR251-4-5P680E

TO: RES, DEP CAR, 470 +/-5%,1/4W/573121/80031/CR251-4-5P470E

Change R50

FROM: RES, DEP CAR, 2.7K +/-5%,1/4W/573261/80031/CR251-4-2K7

TO: RES, DEP CAR, 2.2K +/-5%,1/4W/573246/80031/CR251-4-2K2

Delete the pin 9, 10 and 11 section of U38 and associated connections. Refer to the following partial schematic diagram.

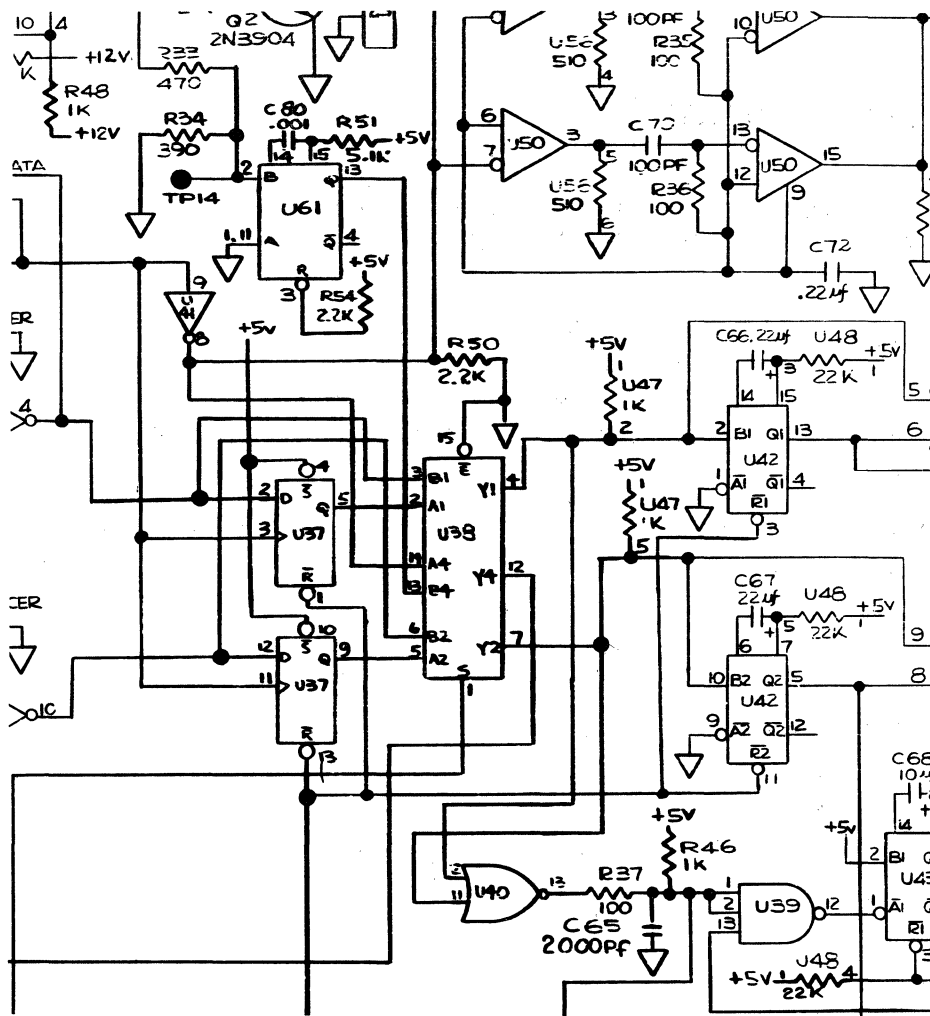

Main Assembly Schematic For REV. D2

Main Assembly - REV. D1 (15271)

Make the REV. D2 changes plus the following changes.

Delete U63
RESISTOR NETWORK/414557/89536/414557

Delete R60 and R61
RES, DEP CAR, 1K+/-5%,1/4W/573170/80031/CR254-4-5P10K

Main Assembly - REV. D (15221)

Make the REV. D1 changes and also delete the 470-ohm resistor connected between U30-2 and +5V.

CHANGE #2

Main Assembly - REV. C3 (15115)

Make changes listed under Change #1 plus the following:

Change U62

FROM: IC, RCM/605055/89536/605055

TO: IC, 3-TO-8 LINE DECODER/407585/01295/SN74LS138

Delete R57 and R58

RES, DEP CAR, 10K+/-5%,1/4W/348839/80031/CR251-4-5P10K

Delete C87 and C88

CAP, CER, 0.22UF +/-20%,50V/519517/51406/RPE111Z5U224M50V

Change U18

FROM: IC, RCM/605089/89536/605089

TO: IC, RCM 536268/89536/536268

Change U19

FROM: IC, RCM/605097/89536/605097

TO: IC, RCM 536276/89536/536276

Change U20

FROM: IC, RCM/605105/89536/605105

TO: IC, RCM 536284/89536/536284

Change U21

FROM: IC, RCM/605113/89536/605113

TO: IC, RCM 586594/89536/586594

On the schematic diagram, delete one-half of U34 and connect U25-9 directly to U22-23.

Refer to the following partial schematic diagram.

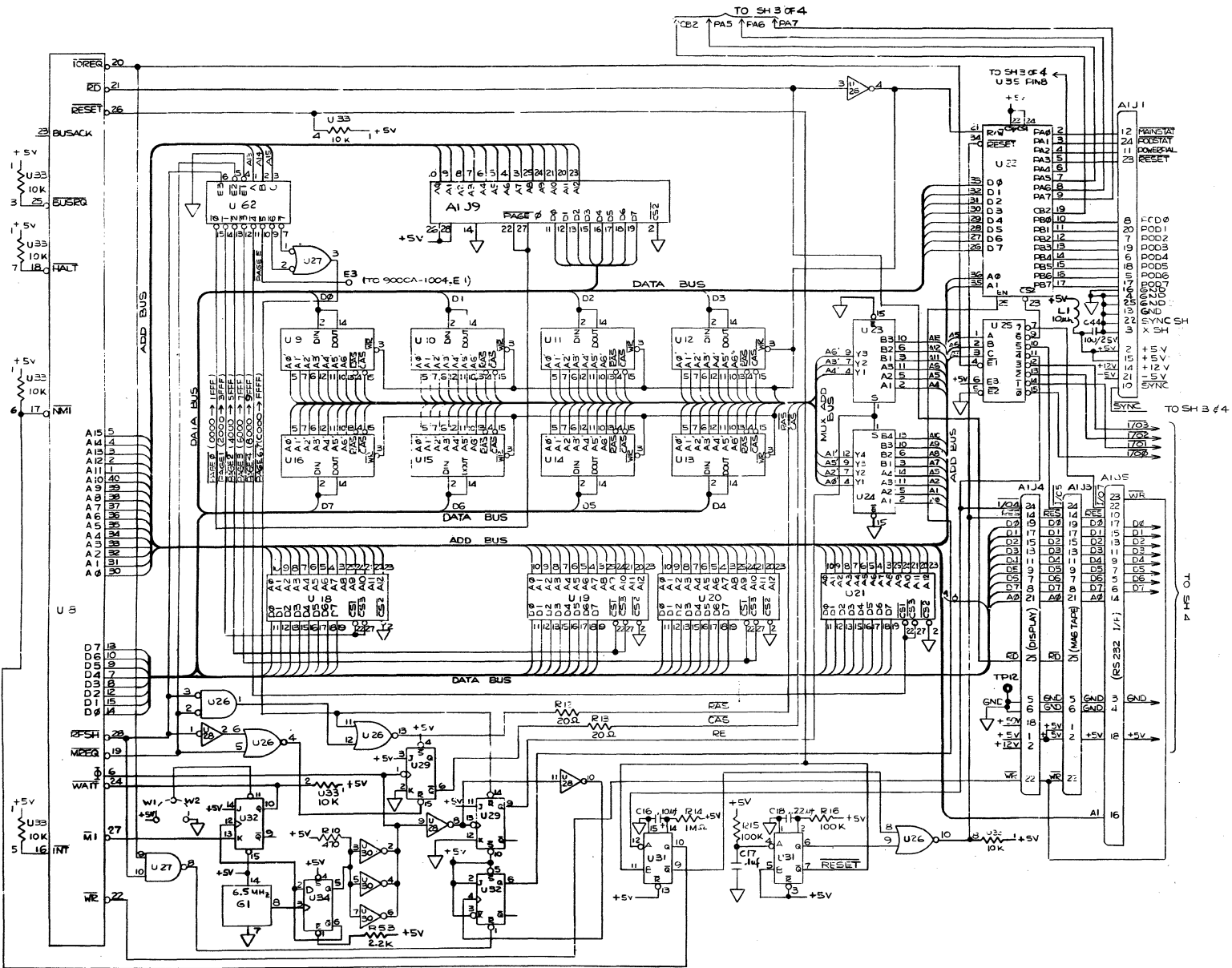

Main Assembly Schematic for Change #2, REV. C3

Main Assembly - REV. C2 (15303)

Make the REV. C3 changes plus the following changes.

Change R43

FROM: RES, DEP CAR, 680 +/-5%,1/4W/573154/80031/CR251-4-5P680E

TO: RES, DEP CAR, 470 +/-5%,1/4W/573121/80031/CR251-4-5P470E

Change R50

FROM: RES, DEP CAR, 2.7K +/-5%,1/4W/573261/80031/CR251-4-2K7

TO: RES, DEP CAR, 2.2K +/-5%,1/4W/573246/80031/CR251-4-2K2

Delete the pin 9, 10 and 11 section of U38 and associated connections. Refer to the partial schematic diagram included under Change #1, REV. D2.

Main Assembly - REV. C1 (15221)

Make the REV. C2 changes and also delete the 470-ohm resistor connected between U30-2 and +5V.

Main Assembly - REV. C (15136)

Make the REV. C1 changes plus the following changes.

Delete R59

RES, COMP, 4.7K +/-5%,1/4W/348821/01121/CB4725

Delete the pin 11, 12 and 13 portion of U44 and the associated connections.

CHANGE #3

Magnetic Tape Assembly - REV. D1 (15835)

Delete CR8 and CR9 from across R27
 DIODE, MULTI-PELLET/375484/09214/MPD300

Add R25
 RES, VAR, 10K +/-10%,1/2W/285171/89536/285171

Change R23 and R24
 FROM: RES, MTL FLM, 100K +/-1%,1/8W/248807/91637/CMF551003F
 TO: RES, MTL FLM, 49.9K +/-1%,1/8W/268821/91637/CMF554992F

Change R29
 FROM: RES, MTL FLM, 40.2K +/-1%,1/8W/235333/91637/CMF554022F
 TO: RES, DEP CAR, 100K +/-5%,1/4W/573584/80031/CR251-4-5P100K

Change R30
 FROM: RES, MTL FLM, 200K +/-1%,1/8W/261701/91637/CMF552003F
 TO: RES, DEP CAR, 200K +/-5%,1/4W/573634/80031/CR251-4-5P68K

Change R31
 FROM: RES, DEP CAR, 27K +/-5%,1/4W/573477/80031/CR251-4-5P27K
 TO: RES, DEP CAR, 68K +/-5%,1/4W/573550/80031/CR251-4-5P68K

Change R35 and R36
 FROM: RES, MTL FLM, 10K +/-1%,1/8W/168260/91637/CMF551002F
 TO: RES, DEP CAR, 10K +/-5%,1/4W/573394/80031/CR251-4-5P10K

Change C12
 FROM: CAP, CER, 39PF +/-5%,1000V/417410/72982/858-000-R2G0-390J
 TO: CAP, CER, 560PF +/-10%,600V/106203/72982/801-00-X5R0-560K

Change C13
 FROM: CAP, CER, 0.01UF +/-20%,100V/407361/72982/8121-A200-W5R-103M
 TO: CAP, CER, 0.22UF +/-20%,50V/519157/51406/RPE111Z5U224M50V

In addition to noting the above component changes on the schematic diagram, also cross-connect the input ends of R21 and R22 so that the HEAD+ input of A4J2 (also collector of Q4) connects to R22, and the HEAD- input (and collector of Q3) connects to R21.

Magnetic Tape Assembly - REV. D & REV. A2 (15699)

Make REV. D1 changes plus the following change.

Delete C16
 CAP, CER, 0.1UF/368647/71590/UK10-140

CHANGE #4

Magnetic Tape Assembly - REV. A1

Make the changes listed under Change #3 plus the following changes.

Change R37

FROM: RES, DEP CAR, 20K +/-2%,1/4W/573444/80031/CR251-4-2P20K
TO: RES, DEP CAR, 100K +/-5%,1/4W/573584/80031/CR251-4-5P100K

Change R6

FROM: RES, COMP, 1.2 +/-5%,1/2W/218701/01121/EB1R25
TO: RES, COMP, 9.1 +/- %,1W/573790/01121/GB9R15

Refer to the following Magnetic Tape Assembly schematic diagram.

Magnetic Tape Assembly - REV. A (15082)

Make the REV. A1 changes plus the following changes.

Change R14

FROM: RES, VAR 500 +/-20%,1/2W/226068/02111/62-1-1-501
TO: RES, VAR, 500 +/-10%,1/2W/291120/89536/291120

Change R45

FROM: RES, DEP CAR, 100 +/-5%,1/4W/573014/80031/CR251-4-5P100E
TO: RES, DEP CAR, 10K +/-5%,1/4W/348839/80031/CR251-4-5P10K

Delete TP3 and TP4

Refer to the following Magnetic Tape Assembly schematic diagram.

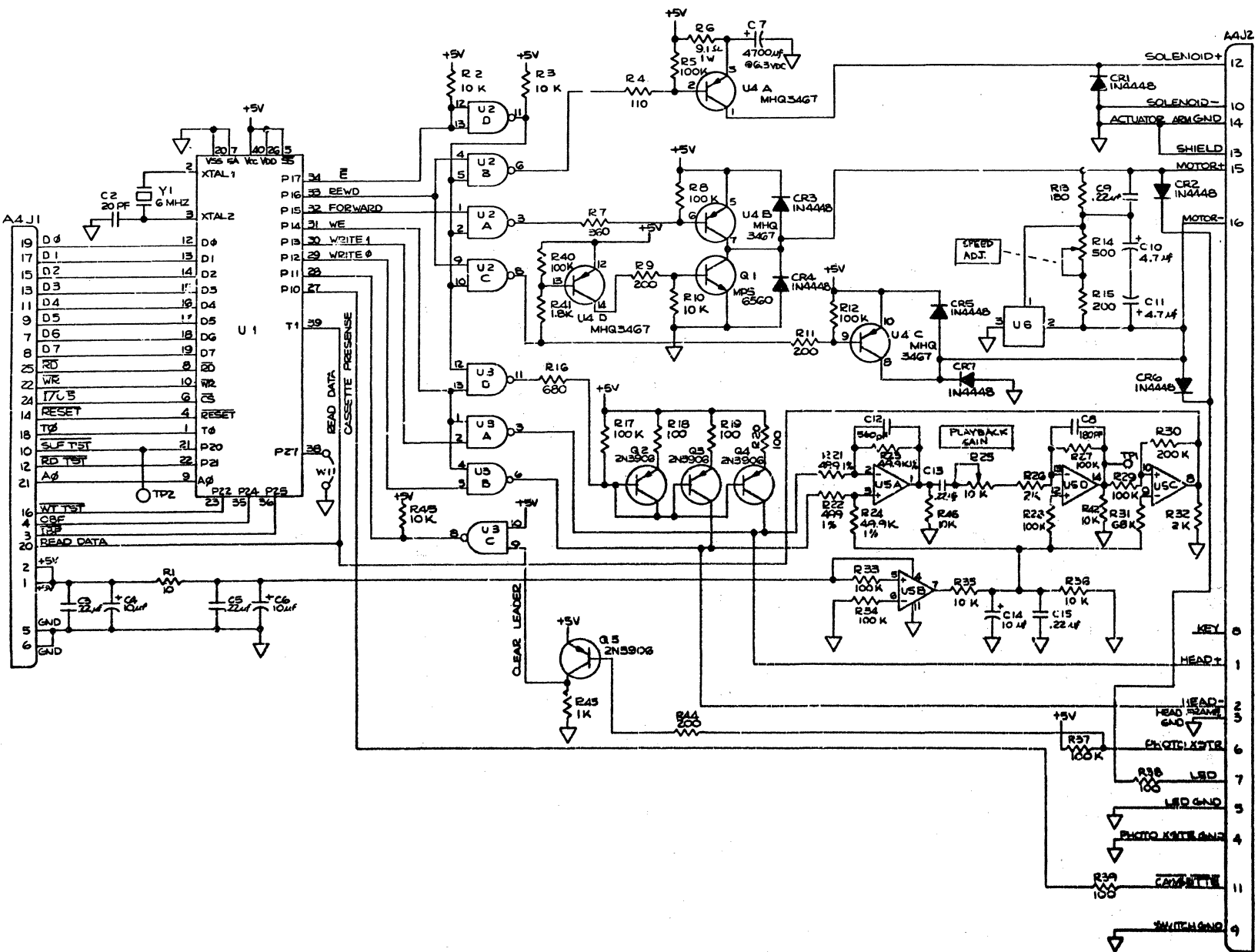

Magnetic Tape Assembly Schematic for Change #4

CHANGE #5

Piggy-Back ROM Assembly - REV. B¹ (15100)

Change U1

FROM: IC, ROM/605071/89536/605071

TO: IC, ROM/536250/89536/536250

Change U2

FROM: IC, ROM/605121/89536/605121

TO: IC, ROM/604165/89536/604165

Refer to the following Piggy-Back ROM Assembly schematic diagram.

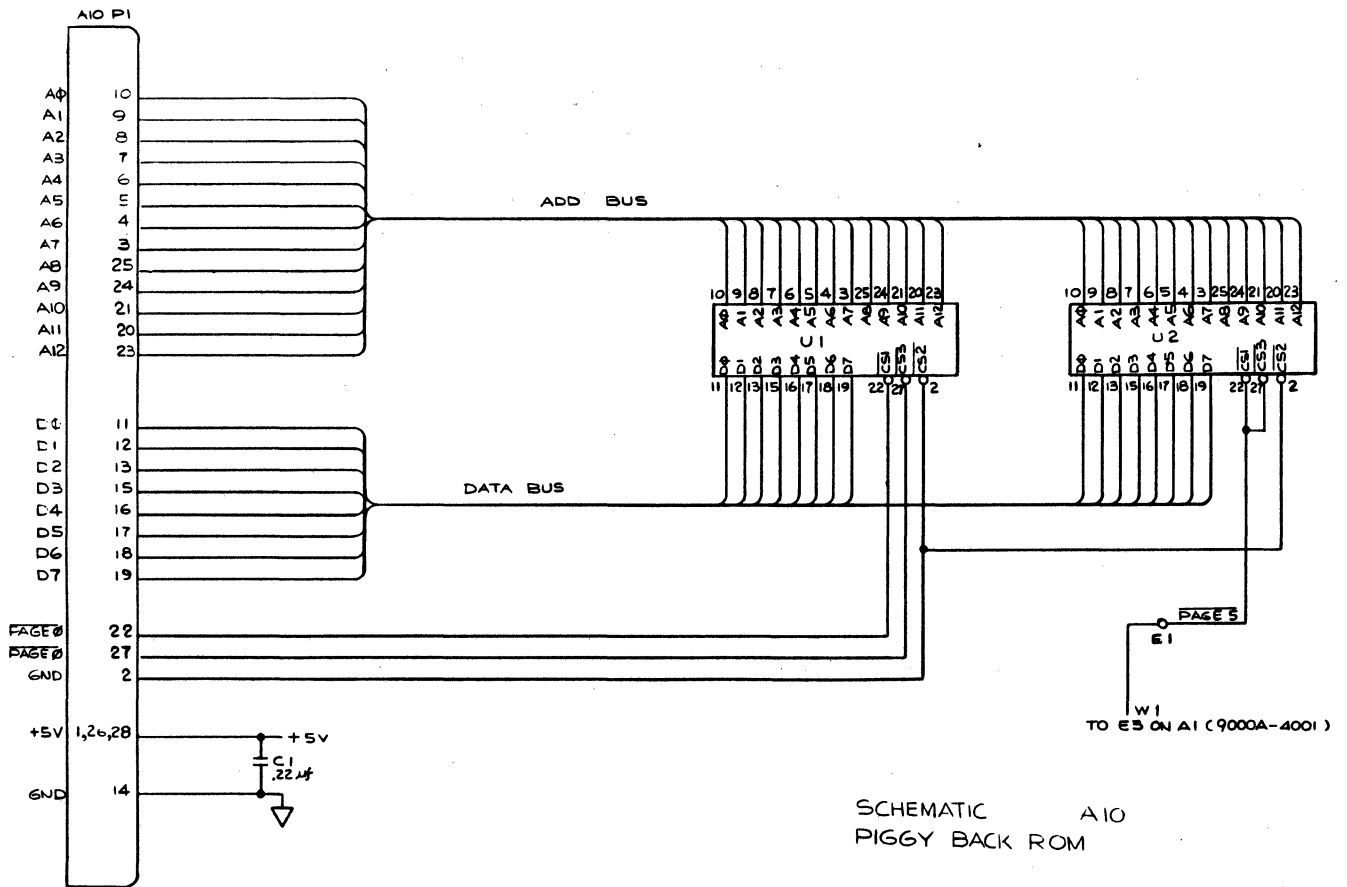

Schematic Diagram for the Piggy Back ROM Assembly, REV. B

CHANGE #6

RS-232 Interface Assembly - REV. C
(PCB 9010A-4035 only)

This earlier RS-232 Interface Assembly is documented in the following illustrated parts breakdown and schematic diagram.

CHANGE #7

RS-232 Interface Assembly - REV. B (15700)
(PCB 9010A-4035 only)

Change the following 9010A-4035 parts list as follows.

Change R4

FROM: RES, DEP CAR, 10K +/-5%,1/4W/348839/80031/CR251-4-5P10K
TO: RES, DEP CAR, 120K +/-5%,1/4W/441386/80031/CR251-4-5P120K

Change R8

FROM: RES, DEP CAR, 10K +/-5%,1/4W/348839/80031/CR251-4-5P10K
TO: RES, DEP CAR, 1M +/-5%,1/4W/348987/80031/CR251-4-5P1M

Delete CR13 and CR14

RS-232 Interface Assembly Parts Breakdown (1 of 2)

REF DES	DESCRIPTION	FLUKE STOCK NO.	MFG SPLY CODE	MFG PART NO.	TOT QTY	REC QTY	NOTE
-001⊗	RS232 PCB ASSEMBLY FIGURE 5-6 (9010A-4035T)	ORDER	BY	OPTION -001	REF		
C1	CAP, ELECT, 47 UF -10/+75%, 16V	519561	89536	519561	3		
C2	CAP, CER, 0.005 UF +/-20%, 50V	255471	51642	200-050-601-502M	1		
C3	CAP, ELECT, 47 UF -10/+75%, 16V	519561	89536	519561	REF		
C4	CAP, ELECT, 47 UF -10/+75%, 16V	519561	89536	519561	REF		
CR1	DIODE, HI-SPEED SWITCHING	203323	04713	1N4448	14	3	
CR2	DIODE, HI-SPEED SWITCHING	203323	04713	1N4448	REF		
CR3	DIODE, HI-SPEED SWITCHING	203323	04713	1N4448	REF		
CR4	DIODE, HI-SPEED SWITCHING	203323	04713	1N4448	REF		
CR5	DIODE, HI-SPEED SWITCHING	203323	04713	1N4448	REF		
CR6	DIODE, HI-SPEED SWITCHING	203323	04713	1N4448	REF		
CR7	DIODE, HI-SPEED SWITCHING	203323	04713	1N4448	REF		
CR8	DIODE, HI-SPEED SWITCHING	203323	04713	1N4448	REF		
CR9	DIODE, HI-SPEED SWITCHING	203323	04713	1N4448	REF		
CR10	DIODE, HI-SPEED SWITCHING	203323	04713	1N4448	REF		
CR11	DIODE, HI-SPEED SWITCHING	203323	04713	1N4448	REF		
CR12	DIODE, HI-SPEED SWITCHING	203323	04713	1N4448	REF		
CR13	DIODE, HI-SPEED SWITCHING	203323	04713	1N4448	REF		
CR14	DIODE, HI-SPEED SWITCHING	203323	04713	1N4448	REF		
J2	CONNECTOR, POST	267500	00779	86144-2	11		
P1	CONNECTOR, 26-PIN	543512	00779	86063-9	1		
Q1	TRANSISTOR, SI, PNP	195974	04713	2N3906	1	1	
Q2	TRANSISTOR, SI, NPN	272237	89536	272237	2	1	
Q3	TRANSISTOR, SI, NPN	272237	89536	272237	REF		
Q4	TRANSISTOR, SI, NPN	218396	04713	2N3904	1	1	
Q5	TRANSISTOR, SI, NPN	218081	04713	MPS6520	1	1	
R1	RES, DEP. CAR, 10K +/-5%, 1/4W	348839	80031	CR251-4-5P10K	4		
R2	RES, DEP. CAR, 10K +/-5%, 1/4W	348839	80031	CR251-4-5P10K	REF		
R3	RES, DEP. CAR, 180 +/-5%, 1/4W	441436	80031	CR251-4-5P180E	1		
R4	RES, DEP. CAR, 10K +/-5%, 1/4W	348839	80031	CR251-4-5P10K	REF		
R5	RES, DEP. CAR, 12K +/-5%, 1/4W	348847	80031	CR251-4-5P12K	1		
R6	RES, DEP. CAR, 200 +/-5%, 1/4W	441451	80031	CR251-4-5P200E	1		
R7	RES, DEP. CAR, 3.9K +/-5%, 1/4W	342600	80031	CR251-4-5P3K9	1		
R8	RES, DEP. CAR, 10K +/-5%, 1/4W	348839	80031	CR251-4-5P10K	REF		
R9	RES, DEP. CAR, 390 +/-5%, 1/4W	441543	80031	CR251-4-5P390E	1		
R10	RES, DEP. CAR, 3K +/-5%, 1/4W	441527	80031	CR251-4-5P3K	1		
R11	RES, DEP. CAR, 1K +/-5%, 1/4W	343426	80031	CR251-4-5P1K	1		
R12	RES, DEP. CAR, 15K +/-5%, 1/4W	348854	80031	CR251-4-5P15K	1		
R13	RES, DEP. CAR, 47 +/-5%, 1/4W	441592	80031	CR251-4-5P47E	1		
R14	RES, DEP. CAR, 1.5K +/-5%, 1/4W	343418	80031	CR251-4-5P	1		
R15	RES, COMP, 15M +/-5%, 1/4W	381491	01121	CB1565	1		
S1	SWITCH, DIP MODULE	495218	00779	435802-3	1	1	
S2	SWITCH, ROTARY	495614	89536	495614	1	1	
T1	TRANSFORMER, DC-DC	461863	89536	461863	1		
TP1	CONNECTOR, POST	267500	00779	86144-2	REF		
TP2	CONNECTOR, POST	267500	00779	86144-2	REF		
TP3	CONNECTOR, POST	267500	00779	86144-2	REF		
TP4	CONNECTOR, POST	267500	00779	86144-2	REF		

RS-232 Interface Assembly Parts Breakdown (2 of 2)

REF DES	DESCRIPTION	FLUKE STOCK NO.	MFG SPLY CODE	MFG PART NO.	TOT QTY	REC QTY	N O T E
TP5	CONNECTOR, POST	267500	00779	86144-2	REF		
TP6	CONNECTOR, POST	267500	00779	86144-2	REF		
U1Ⓞ	IC, C-MOS, ASYNCRNS, REC/TRANSMITTER	453464	32293	IM6402CPL	1	1	
U2Ⓞ	IC, C-MOS, BIT RATE GENERATOR	418921	04713	MC14411P	1	1	
U3Ⓞ	IC, C-MOS, INPUT MULTIPLEXER, W/3-STATE	504647	04713	MC14512BCP	1	1	
U4	IC, PHOTOTRANSISTOR, OPTICALLY COUPLD	504977	29083	MCT2E	2	1	
U5	IC, PHOTOTRANSISTOR, OPTICALLY COUPLD	504977	29083	MCT2E	REF		
U6Ⓞ	IC, C-MOS, QUAD, 2-INPUT OR GATES	408393	18725	CD4071BE	1	1	
U7	IC, LINEAR, 5-TRANSISTOR ARRAY	248906	12040	LM3046N	1	1	
U8	RESISTOR NETWORK	412924	89536	412924	1	1	
U9	RESISTOR NETWORK	413286	89536	413286	2	1	
U10	RESISTOR NETWORK	413286	89536	413286	REF		
XU1	SOCKET, IC, 40-PIN	429282	09922	DILB40P-108	1		
XU2	SOCKET, IC, 24-PIN	376236	91506	324-AG39D	1		
Y1	CRYSTAL, 1.8432 MHZ, +/-0.01%	424184	89536	424184	1	1	

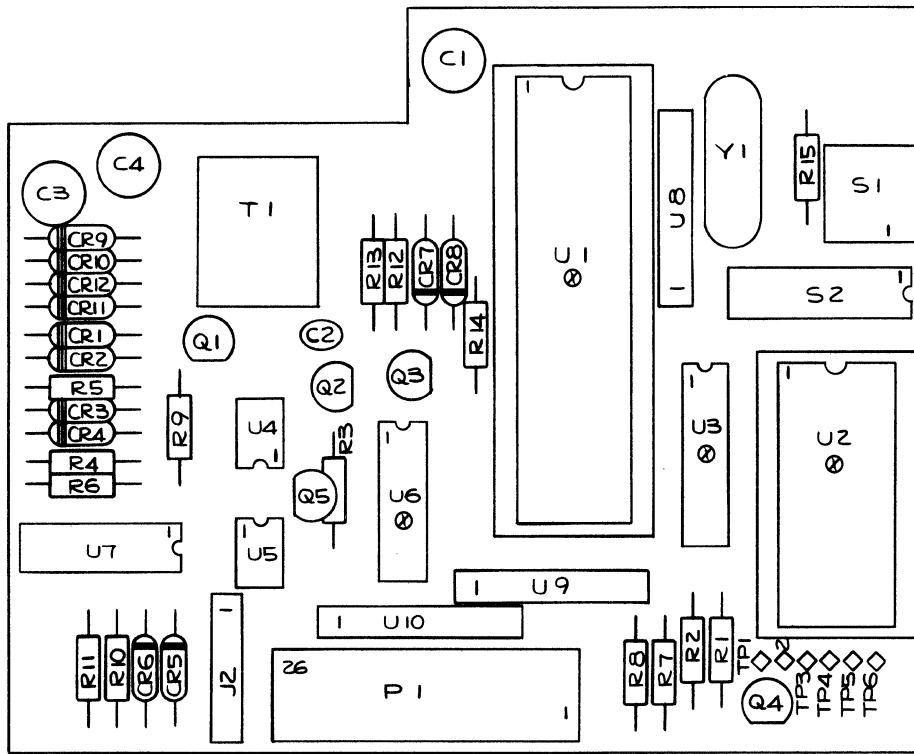

RS-232 Interface Assembly Reference Designation Diagram

RS-232 Interface Assembly Schematic Diagram

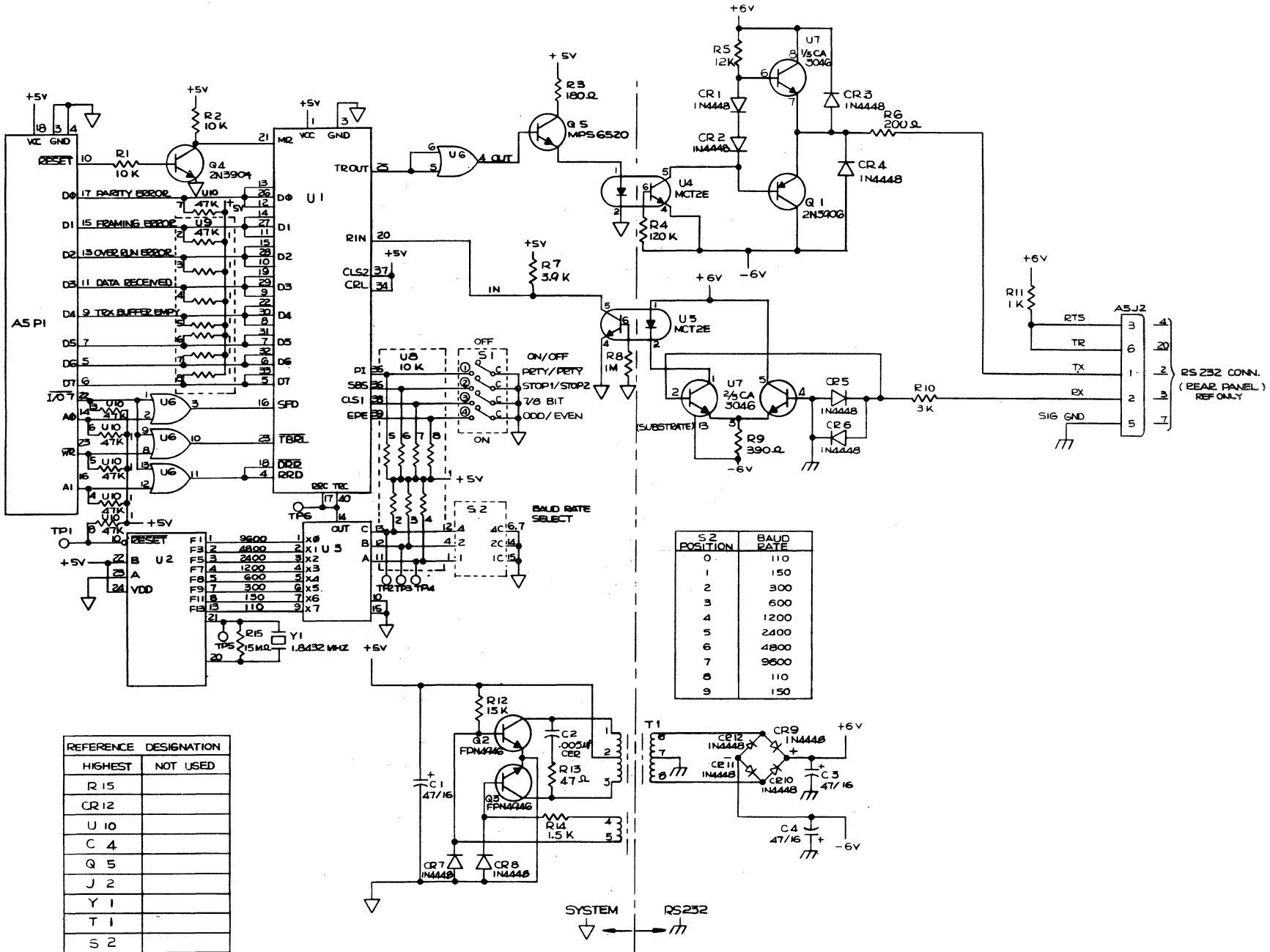

Section 8

Schematic Diagrams

FIGURE	TITLE	PAGE
8-1.	9010A Interconnect Diagram	8-3
8-2.	A1 Main PCB Assembly	8-4
8-3.	A2 Display PCB Assembly	8-12
8-4.	A3 Keyboard PCB Assembly	8-14
8-5.	A4 Magnetic Tape PCB Assembly	8-16
8-6.	A7 Data Probe PCB Assembly	8-18
8-7.	A10 Piggy Back ROM Assembly	8-19
8-8.	Option -001, RS-232 Interface PCB Assembly	8-20

NOTES

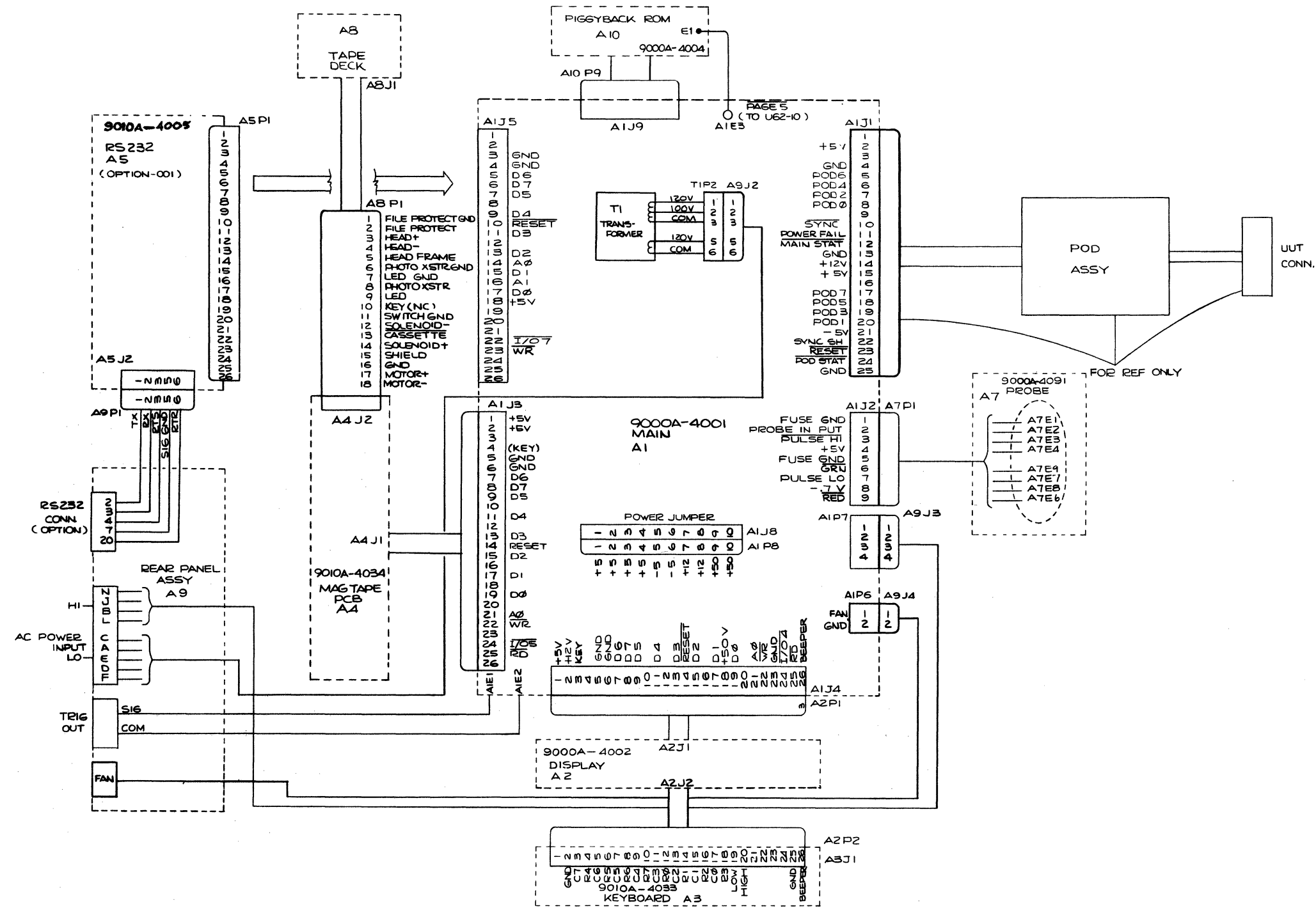
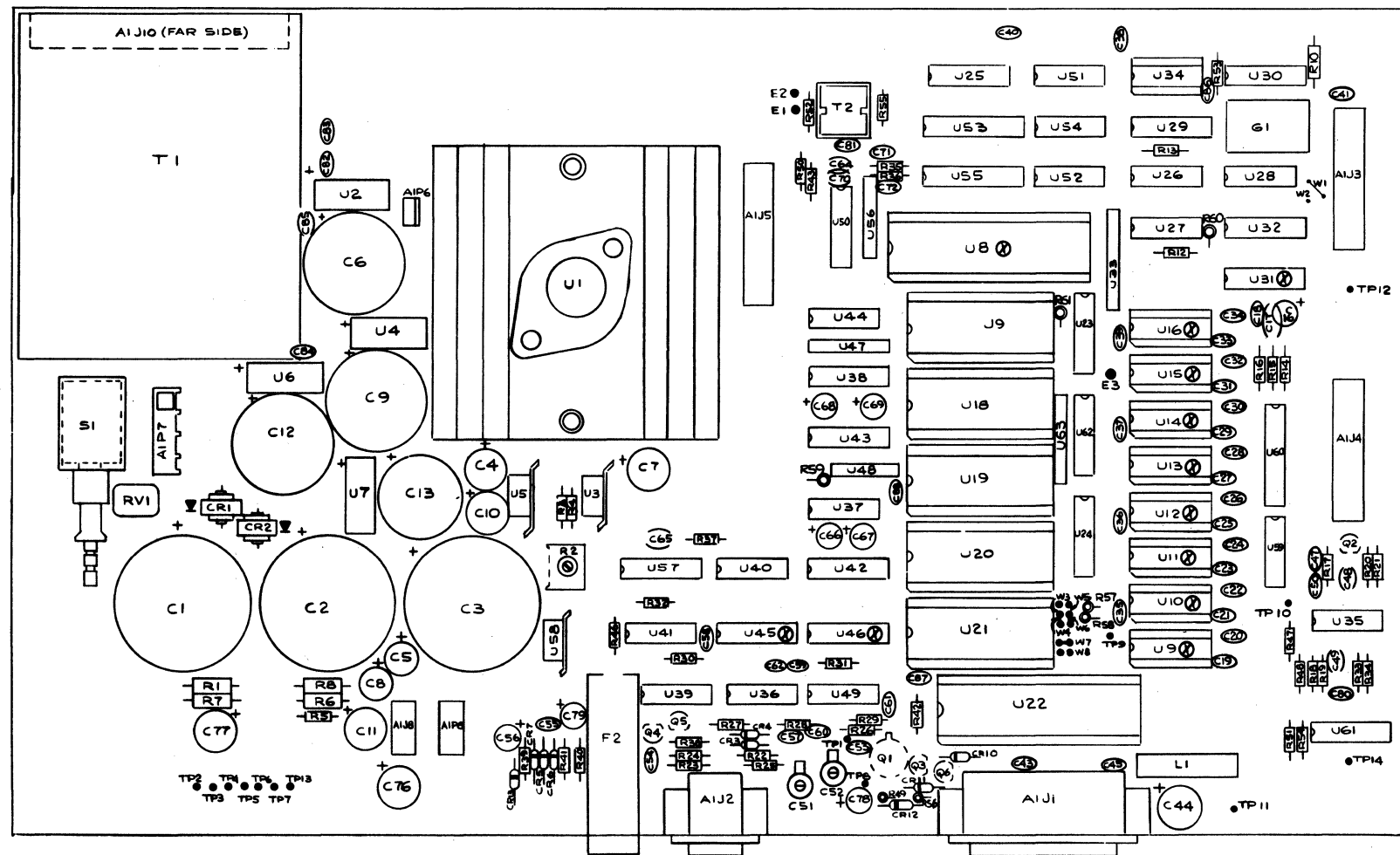

Figure 8-1. 9010A Interconnect Diagram

CAUTION
SUBJECT TO DAMAGE BY
STATIC ELECTRICITY



9000A-1601

Figure 8-2. A1 Main PCB Assembly

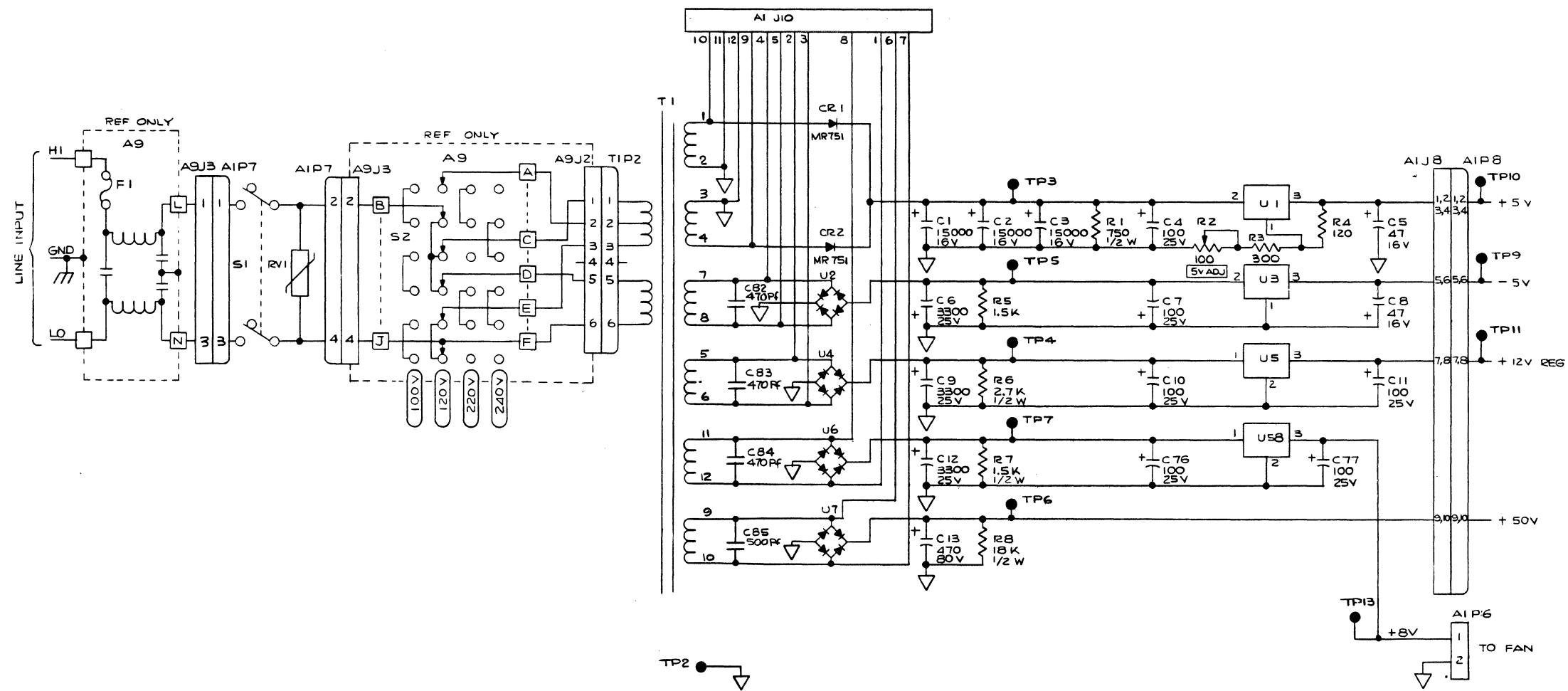

DES	DEVICE	+5V	-5V	+12V	+12V UN	+50V	GND	QTY
U 1	LM338K	3	—	—	—	—	—	1
U 3	LM7905	—	3	—	—	—	1	1
U 5	LM7812	—	—	3	—	—	—	2
J 2,4	KBPO2	—	—	—	—	—	—	2
U 6	KBPO2	—	—	—	—	—	—	1
J 7	KBPO6	—	—	—	—	—	—	1
U 8	LM7808	—	—	—	—	—	2	1

REF	DES
HIGHEST NO	NOT USED NO.
TP 14	
E 3	
W 8	
R 61	R44
C 88	C42
CR 12	
U 63	U18
Q 6	
S 1	
RV 1	
S 2	
L 1	
T 2	
J 10	
F 2	

NOTES:
 1. UNLESS OTHERWISE SPECIFIED:
 ALL RESISTORS ARE IN OHMS, 1/4W, 5%.
 ALL CAPACITORS ARE IN MICROFARADS.

Figure 8-2. A1 Main PCB Assembly (cont)

CAUTION
SUBJECT TO DAMAGE BY
STATIC ELECTRICITY

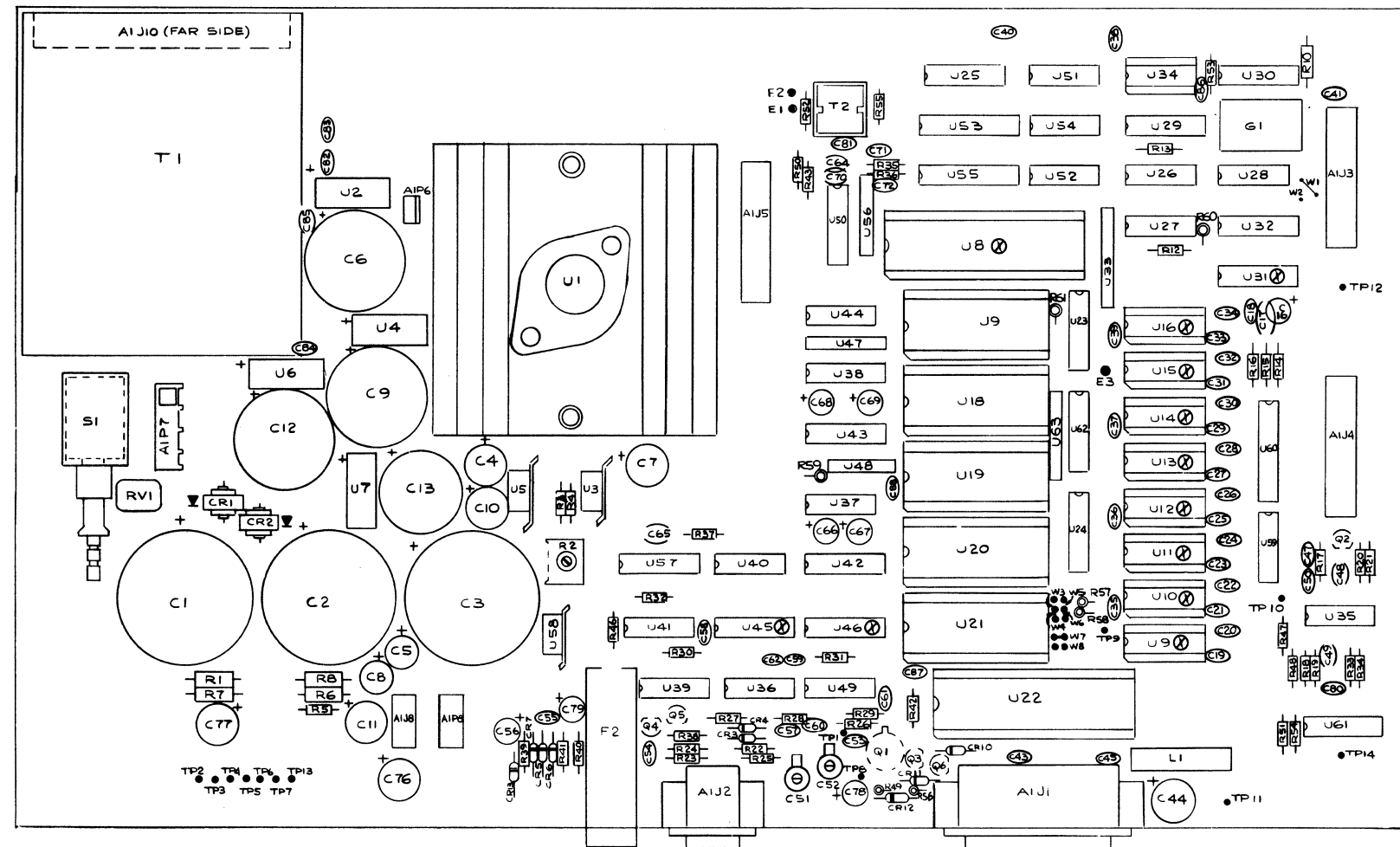

9000A-1601

Figure 8-2. A1 Main PCB Assembly (cont)

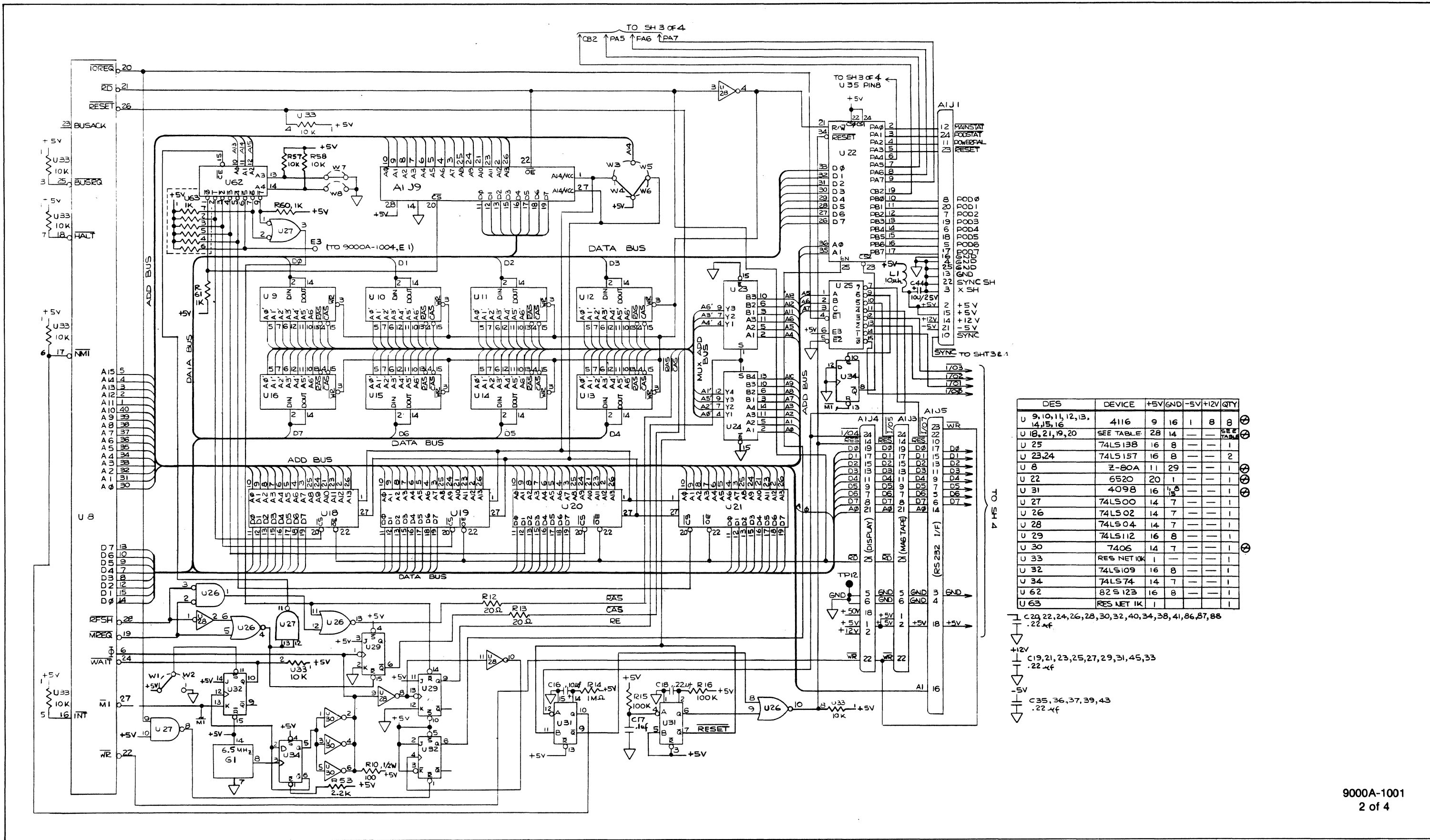

DES	DEVICE	+5V	GND	-5V	+12V	QTY
U 9,10,11,12,13,14,15,16	4116	9	16	1	8	8
U 18,21,19,20	SEE TABLE	28	14	—	—	SEE TABLE
U 25	74LS138	16	8	—	—	1
U 23,24	74LS157	16	8	—	—	2
U 8	Z-80A	11	29	—	—	1
U 22	6520	20	1	—	—	1
U 31	4098	16	8	—	—	1
U 27	74LS00	14	7	—	—	1
U 26	74LS02	14	7	—	—	1
U 28	74LS04	14	7	—	—	1
U 29	74LS112	16	8	—	—	1
U 30	7406	14	7	—	—	1
U 33	RES NET 10K	1	—	—	—	1
U 32	74LS109	16	8	—	—	1
U 34	74LS74	14	7	—	—	1
U 62	82S123	16	8	—	—	1
U 63	RES NET 1K	1	—	—	—	1

- ⊖ C20,22,24,26,28,30,32,40,34,38,41,86,87,88 .22 μf
- ⊖ +12V C19,21,23,25,27,29,31,45,33 .22 μf
- ⊖ -5V C35,36,37,39,43 .22 μf

Figure 8-2. A1 Main PCB Assembly (cont)

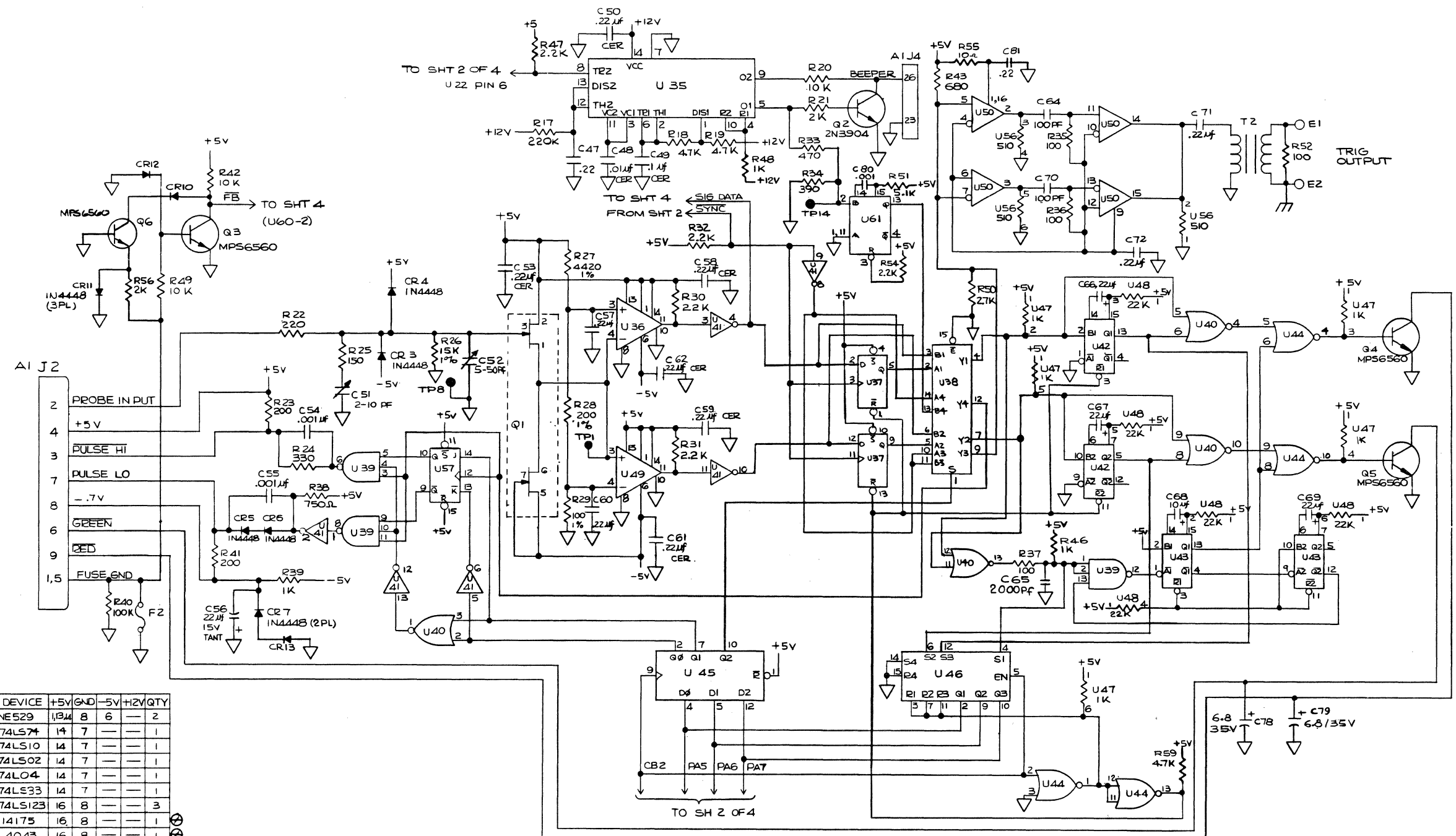

DES	DEVICE	+5V	GND	-5V	+12V	QTY
U 36,49	NE529	1,8	4	6	—	2
U 37	74LS74	14	7	—	—	1
U 39	74LS10	14	7	—	—	1
U 40	74LS02	14	7	—	—	1
U 41	74LS04	14	7	—	—	1
U 44	74LS33	14	7	—	—	1
U61,42,43	74LS123	16	8	—	—	3
U 45	14175	16	8	—	—	1
U 46	4043	16	8	—	—	1
U 38	74LS157	16	8	—	—	1
U 47,	1K RES.NET.	1	—	—	—	1
U48,	10K RES.NET.	1	—	—	—	1
U 35	NE556	—	7	—	14	1
U 50	10115	—	8	—	—	1
U 57	74LS109	16	8	—	—	1
U56,	500Ω RES.NET.	—	1	—	—	—

Figure 8-2. A1 Main PCB Assembly (cont)

CAUTION
SUBJECT TO DAMAGE BY
STATIC ELECTRICITY

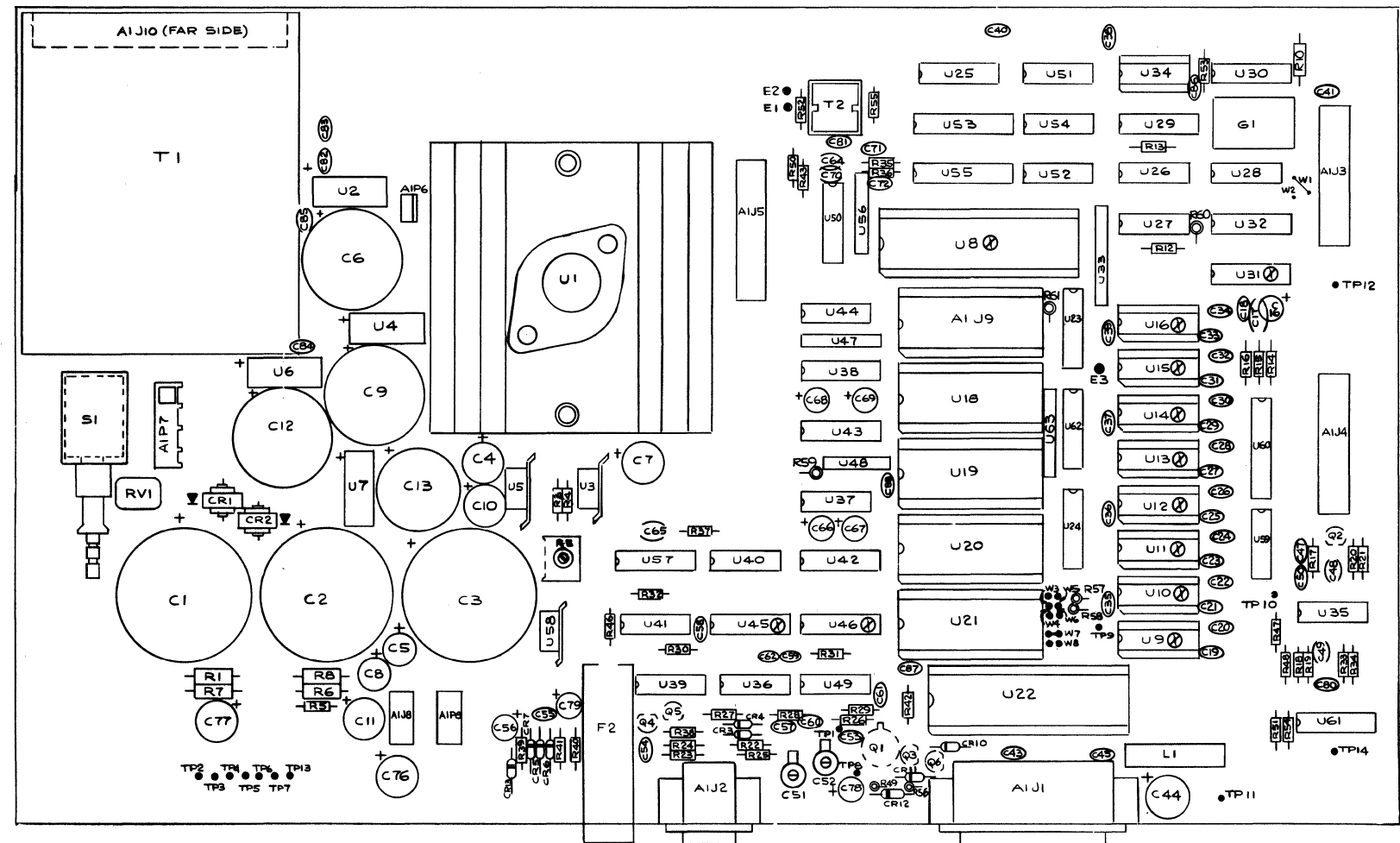

9000A-1601

Figure 8-2. A1 Main PCB Assembly (cont)

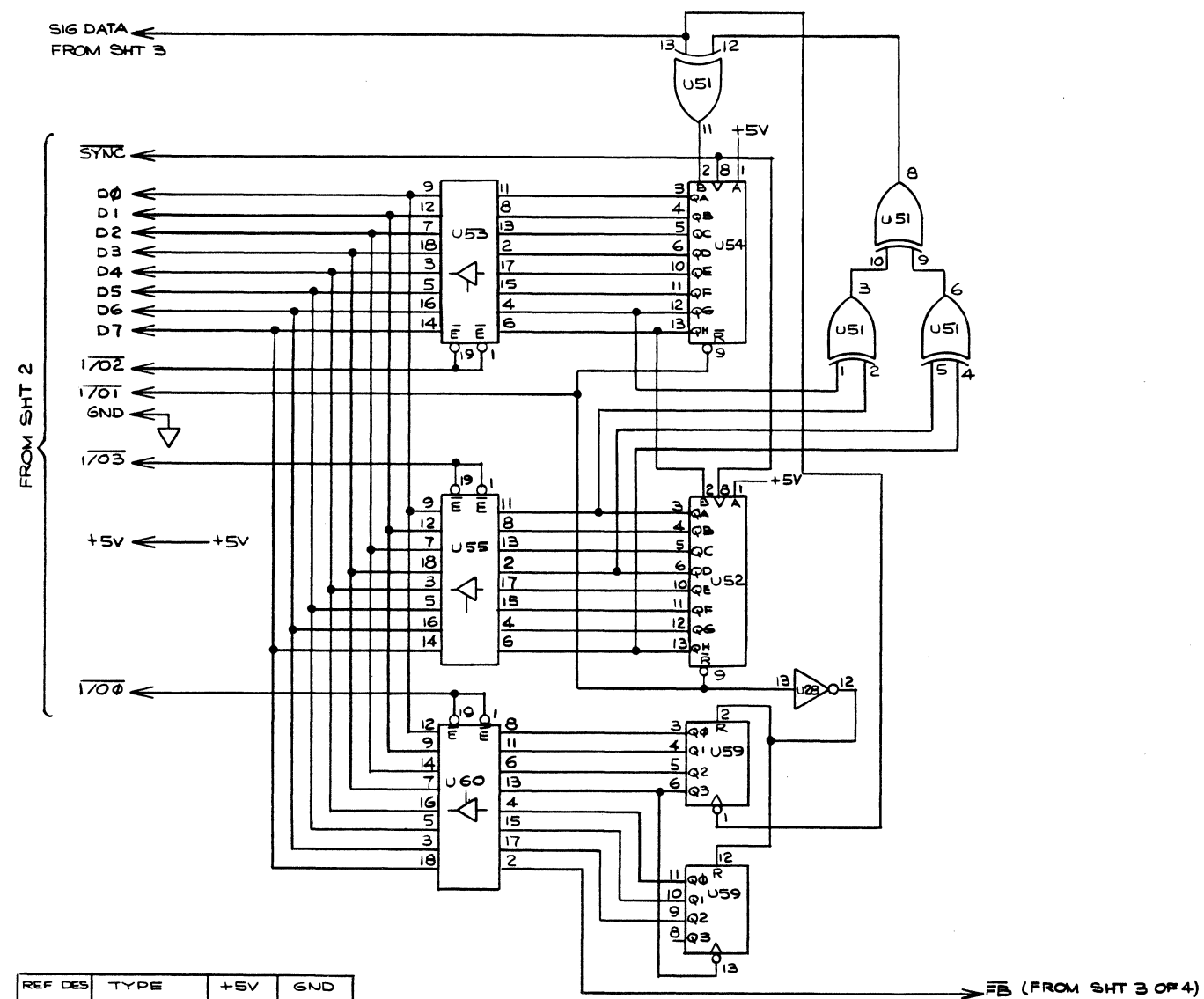

REF DES	TYPE	+5V	GND
U51	74LS06	14	7
U52,54	74LS164	14	7
U53,55,56	74LS244	20	10
U59	74LS393	14	7
U28	74LS04	14	7

Figure 8-2. A1 Main PCB Assembly (cont)

CAUTION
SUBJECT TO DAMAGE BY
STATIC ELECTRICITY

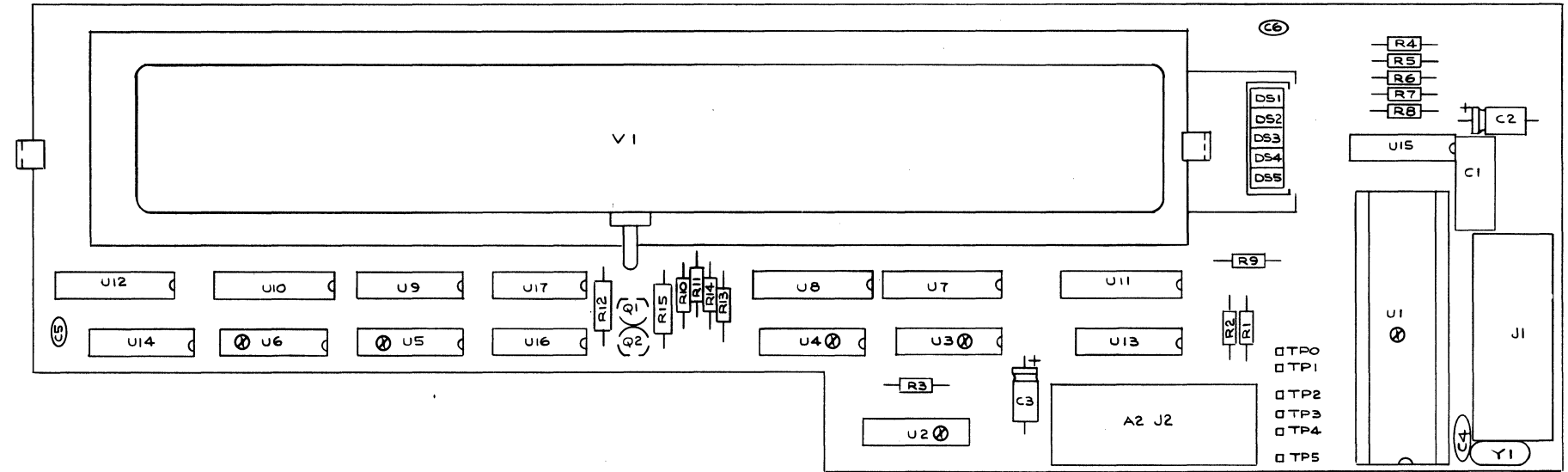

9000A-1602

Figure 8-3. A2 Display PCB Assembly

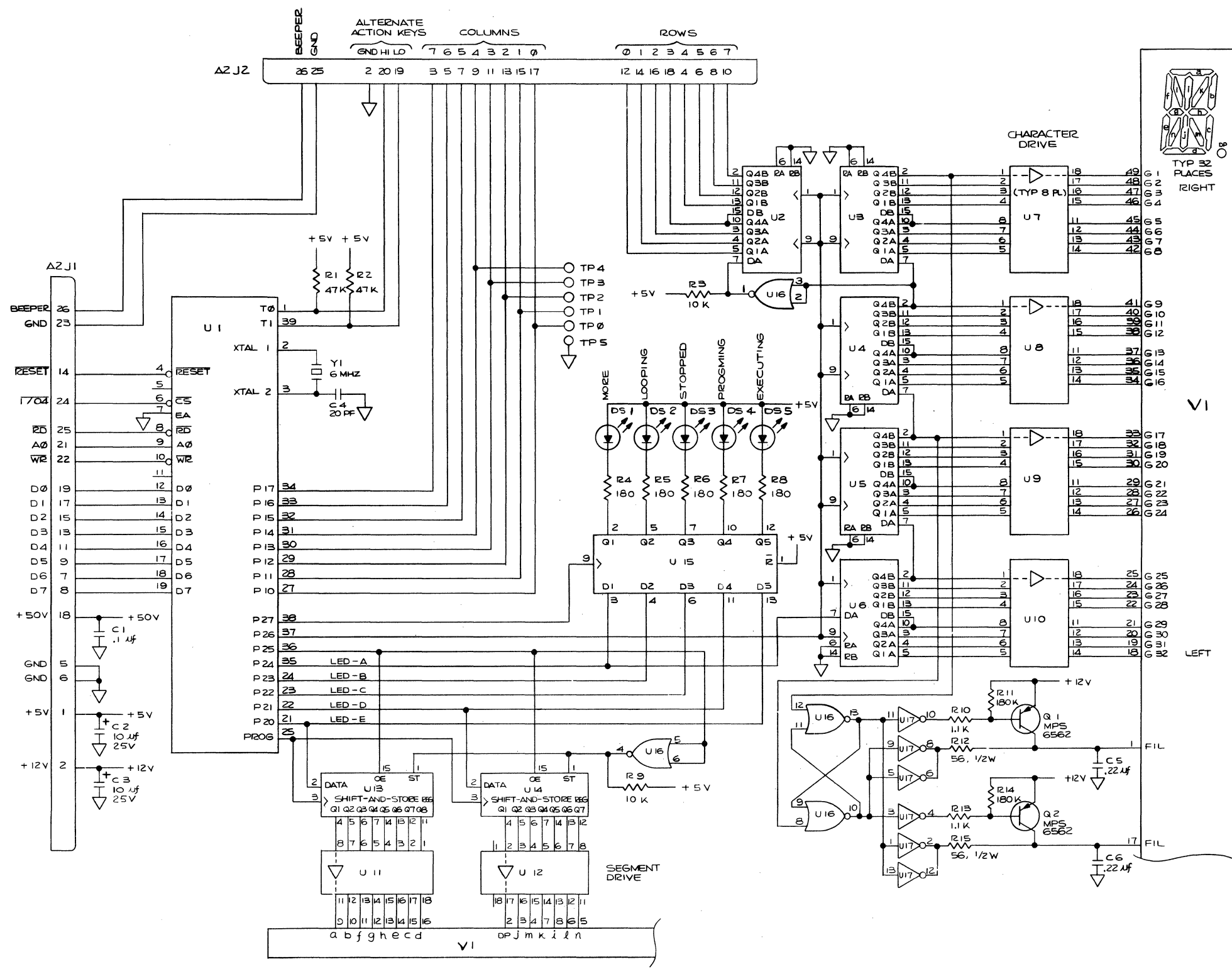

NOTES
 1 UNLESS OTHERWISE SPECIFIED
 ALL RESISTORS ARE IN OHMS, 1/4W.
 CARBONFILM AND 5%

REF	DES
HIGHEST	NOT USED
U 17	
R 15	
C 6	
Q 2	
DS 5	
Y 1	
J 2	
DSP 1	

REF	TYPE	+5V	GND	+12V	+50V	QTY
U 7,8,9 10,11,12	UDN-6118A	9	10	6		
U 2,3,4 5,6	4015	16	8			5
U 1	8041	26,40	20			1
U 13, 14	4094	16	8			2
U 15	74174	16	8			1
U 16	74LS02	14	7			1
U 17	7416	14	7			1

Figure 8-3. A2 Display PCB Assembly (cont)

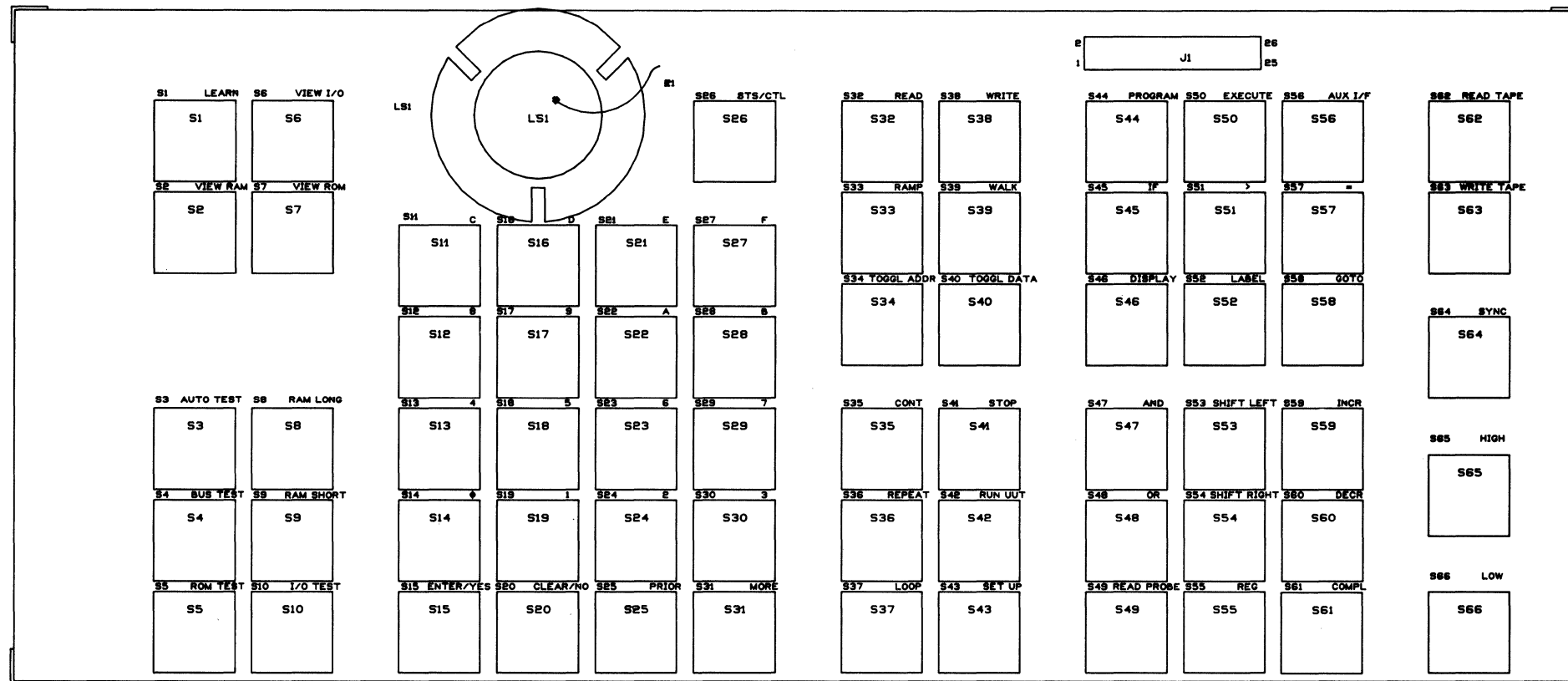

Figure 8-4. A3 Keyboard PCB Assembly

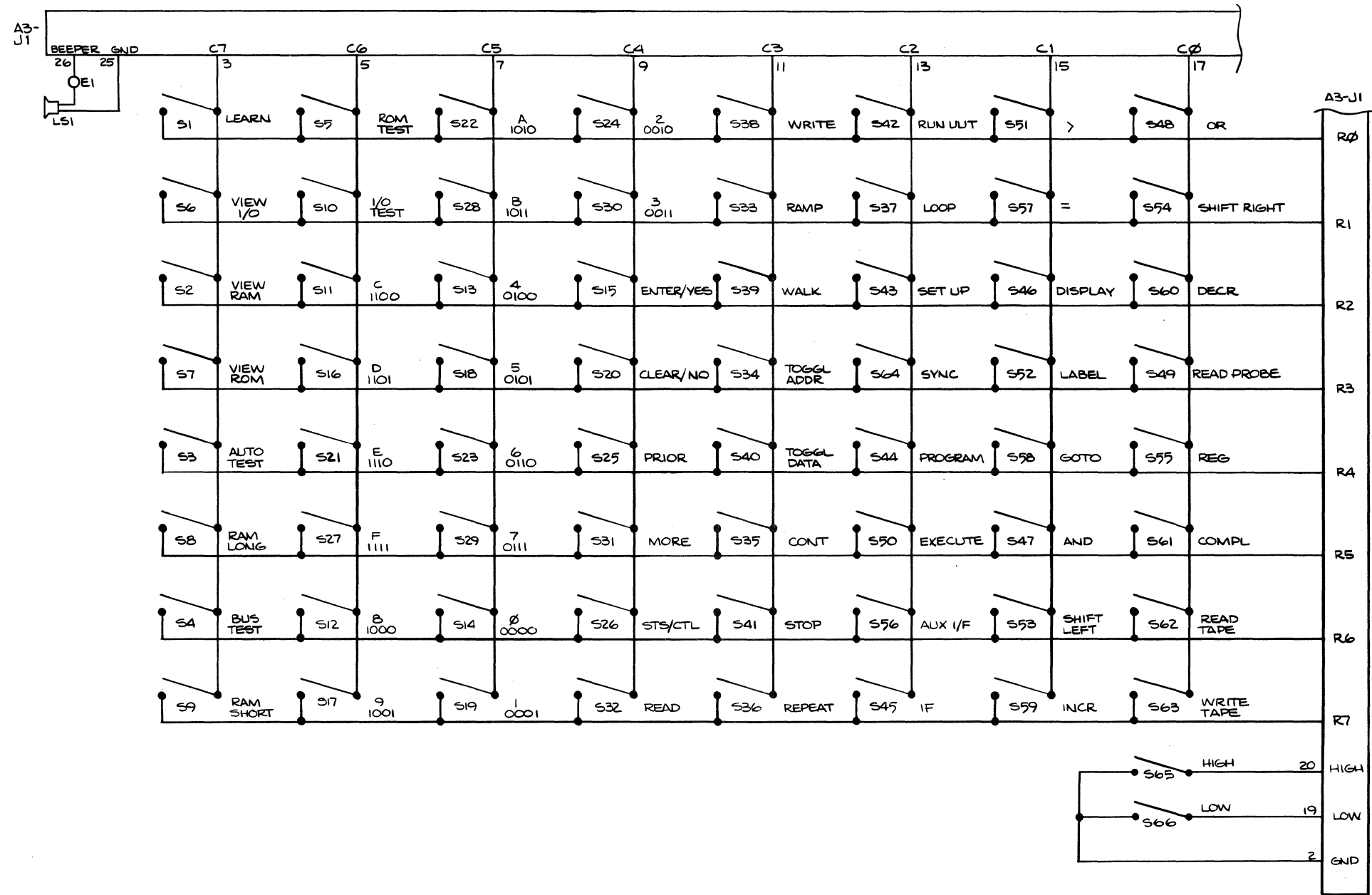
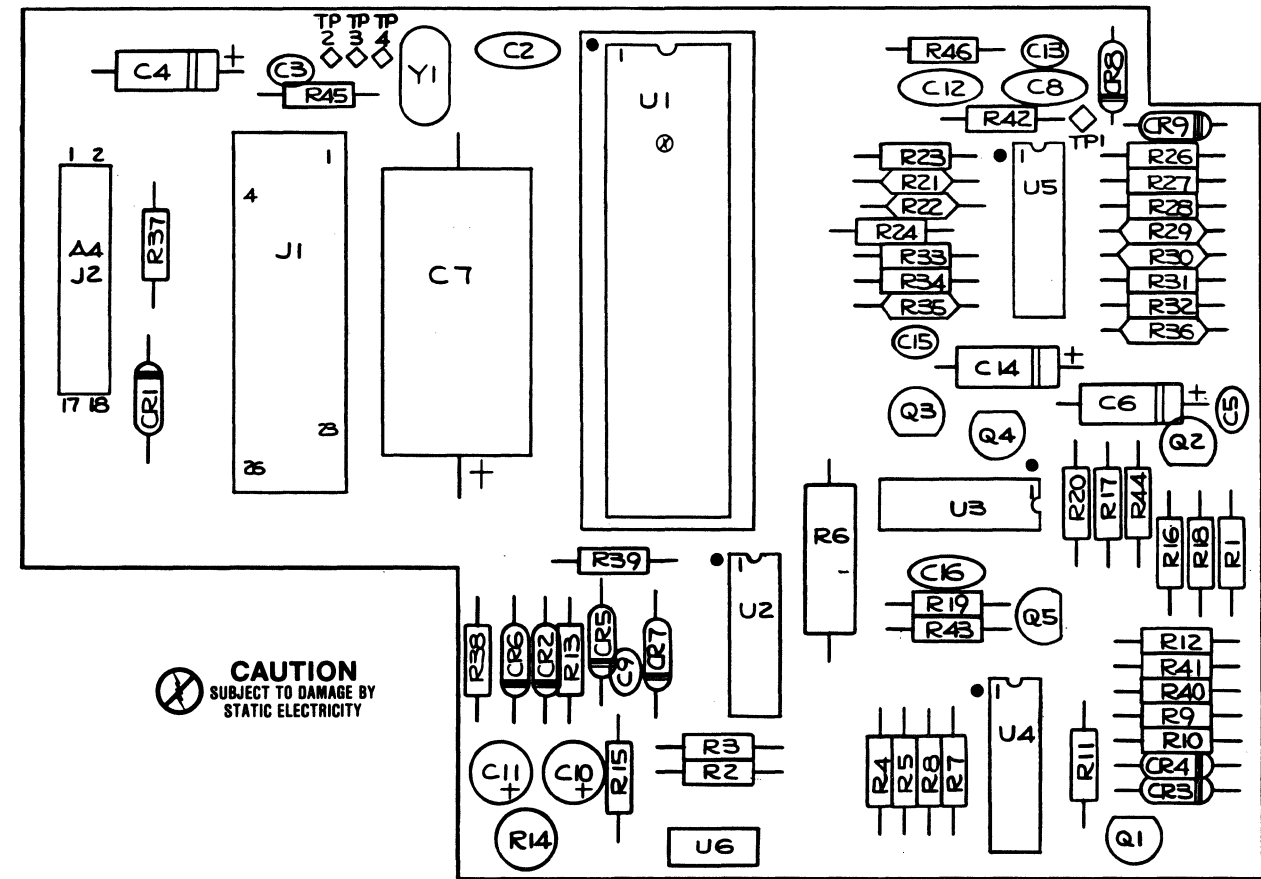
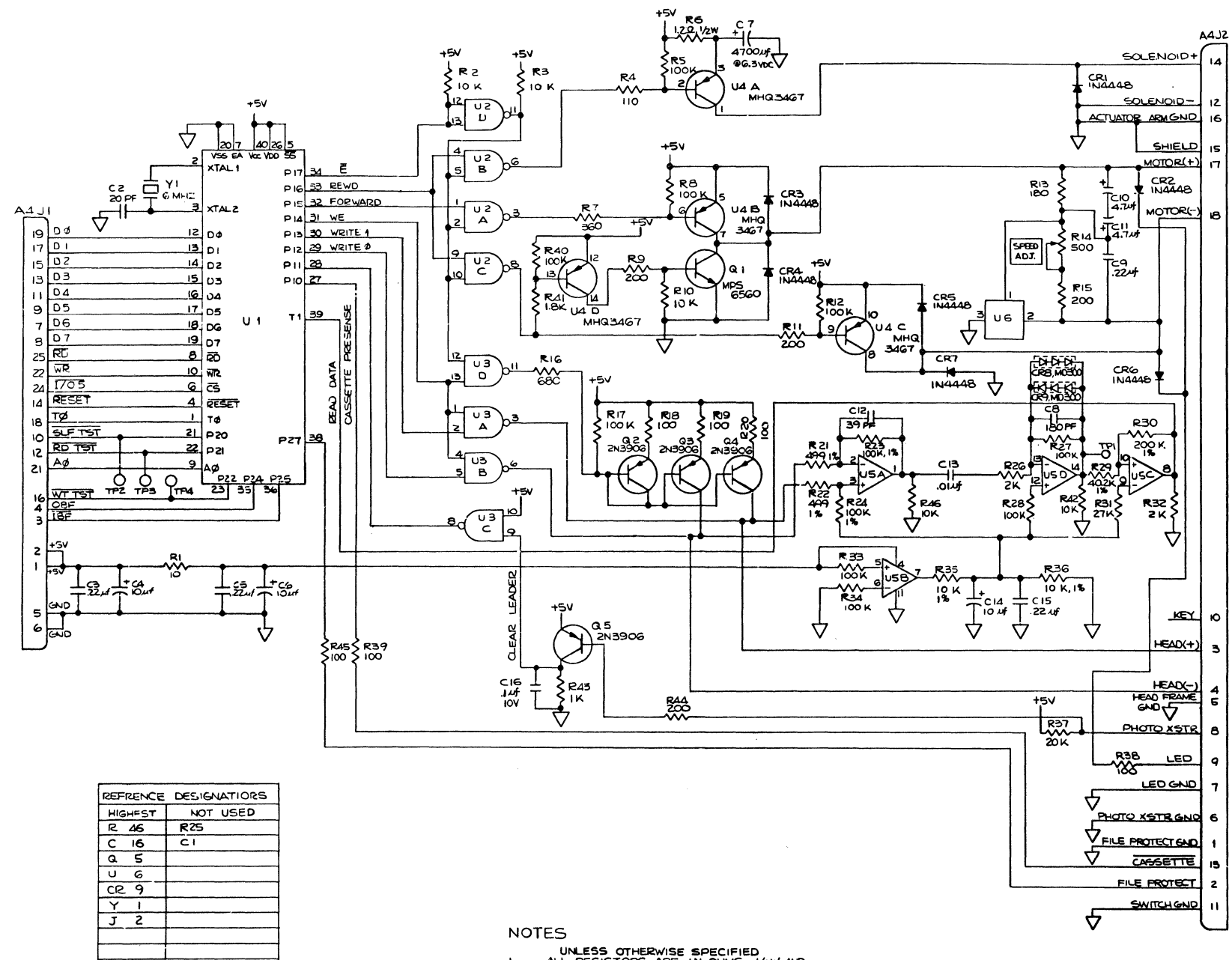

Figure 8-4. A3 Keyboard PCB Assembly (cont)



CAUTION
SUBJECT TO DAMAGE BY
STATIC ELECTRICITY

Figure 8-5. A4 Magnetic Tape PCB Assembly



REF	TYPE	+5V	GND	QTY
U 1	8041	40.26	20	1
U 2,3	74LS38	14	7	2
U 5	LM324	4	11	1
U 6	TDA1151	—	3	1
U 4	MHQ3467	—	—	—

REFERENCE DESIGNATORS	
HIGHEST	NOT USED
R 46	R 25
C 16	C 1
Q 5	
U 6	
CR 9	
Y 1	
J 2	

NOTES
 1 UNLESS OTHERWISE SPECIFIED, ALL RESISTORS ARE IN OHMS, 1/4W AND 5%.
 2 ALL CAPACITORS ARE IN MICROFARADS

Figure 8-5. A4 Magnetic Tape PCB Assembly (cont)

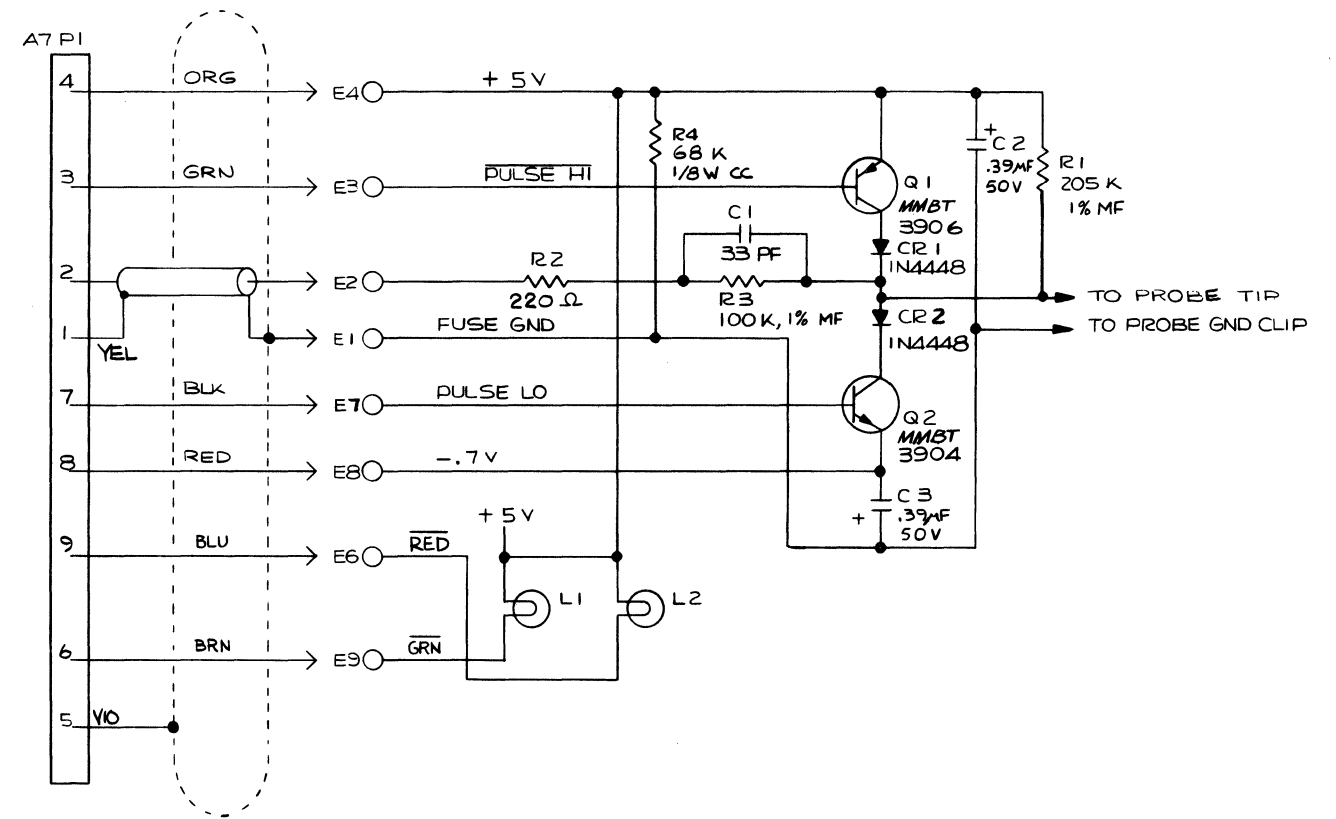
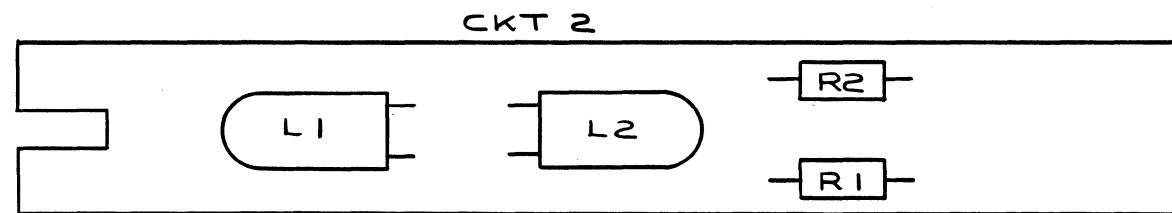
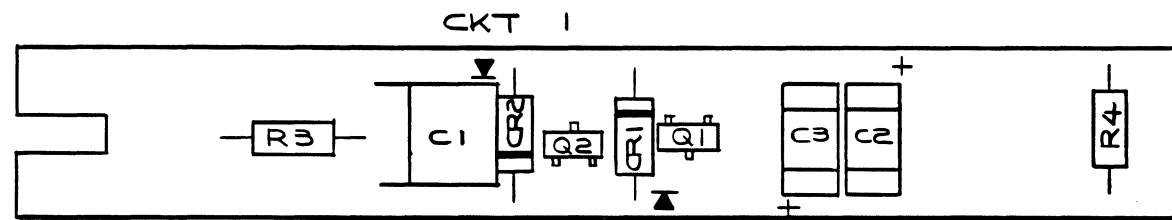

9000A-1691

9000A-1091

Figure 8-6. A7 Data Probe PCB Assembly

CAUTION
SUBJECT TO DAMAGE BY
STATIC ELECTRICITY

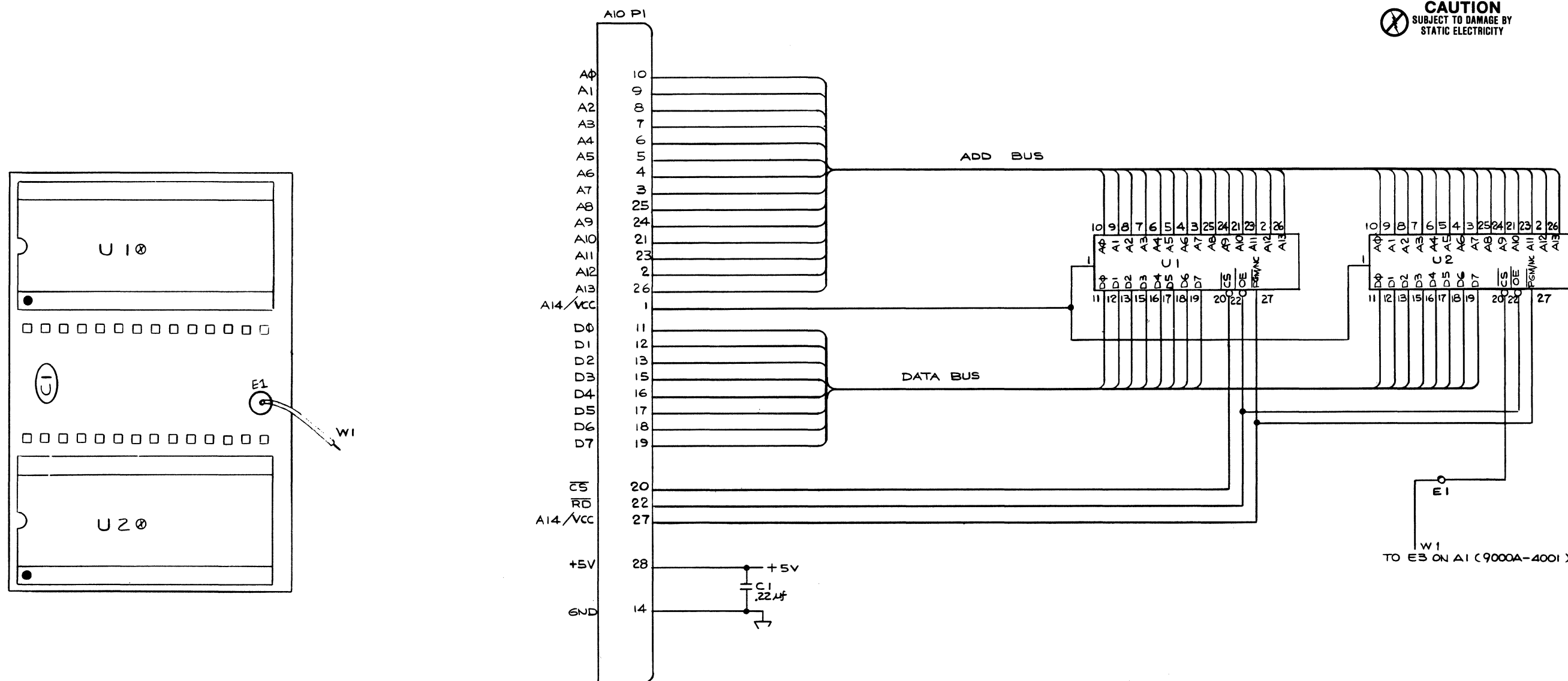

- NOTES: UNLESS OTHERWISE SPECIFIED:
1. ALL RESISTANCES ARE IN OHMS, 1/4W, 5%.
 2. ALL CAPACITANCES ARE IN MICROFARADS.

9000A-1604

9000A-1004

Figure 8-7. A10 Piggy Back ROM Assembly (cont)

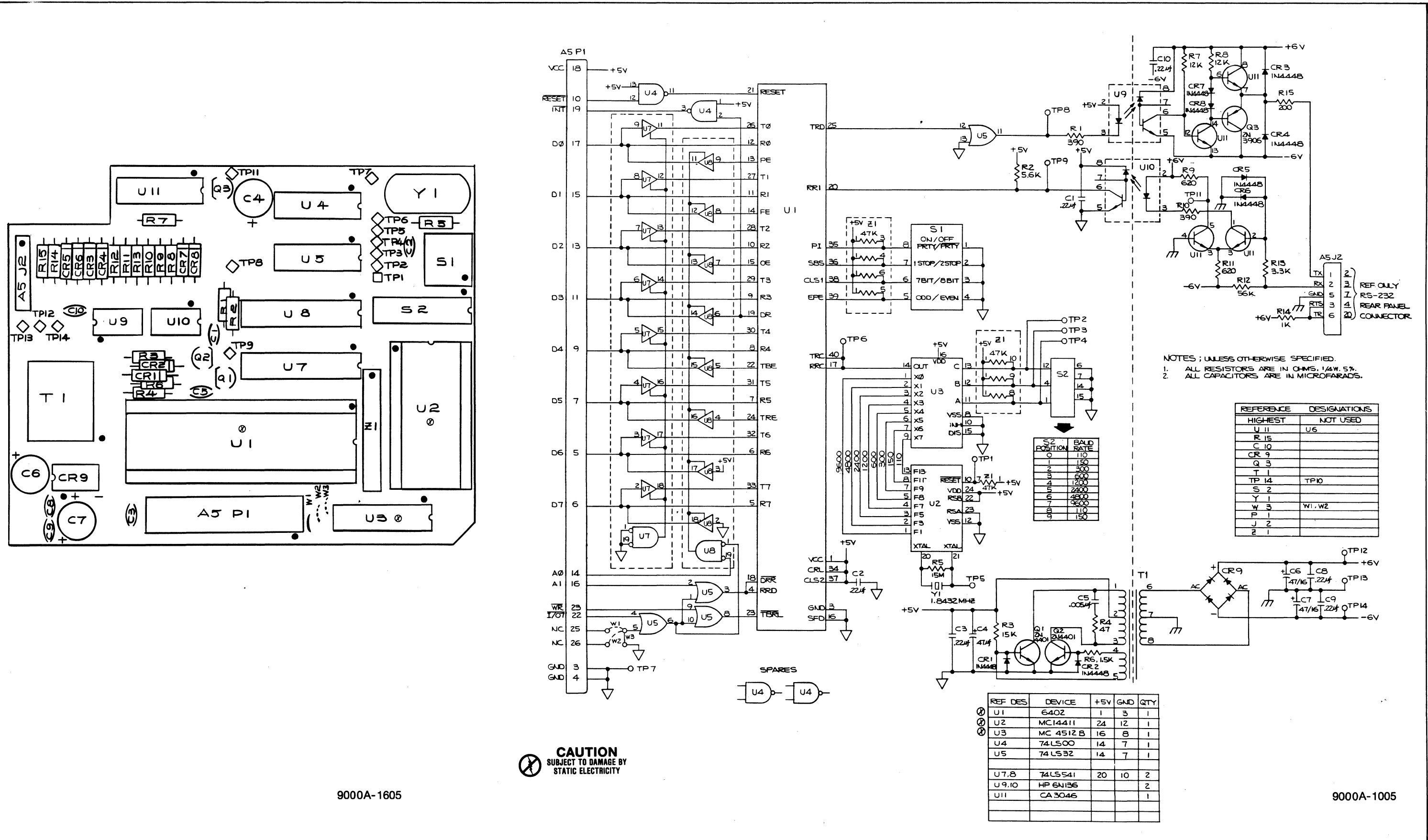

CAUTION
SUBJECT TO DAMAGE BY
STATIC ELECTRICITY

9000A-1605

9000A-1005

REF DES	DEVICE	+5V	GND	QTY
U1	6402	1	3	1
U2	MC14411	24	12	1
U3	MC 4512B	16	8	1
U4	74LS00	14	7	1
U5	74LS32	14	7	1
U7,8	74LS541	20	10	2
U9,10	HP 6N136			2
U11	CA 3046			1

REFERENCE	DESIGNATIONS
HIGHEST	NOT USED
U 11	
R 15	U5
C 10	
CR 9	
Q 3	
T 1	
TP 14	TP10
S 2	
Y 1	
W 3	W1, W2
F 1	
J 2	
Z 1	

- NOTES ; UNLESS OTHERWISE SPECIFIED.
 1. ALL RESISTORS ARE IN OHMS, 1/4W, 5%.
 2. ALL CAPACITORS ARE IN MICROFARADS.

Figure 8-8. Option-001, RS-232 Interface PCB Assembly