

MODEL WP-919 EXPANSION CABINET

DOCUMENTATION PACKAGE

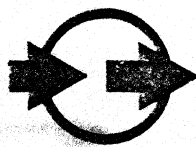

WESPERLINE™

Division of WESPERCORP

1100 CLAUDINA PL. • ANAHEIM, CA 92805 U.S.A. • (714) 991-8674

REV 7-9-79

WP-919 EXPANSION CHASSIS

1. GENERAL DESCRIPTION - The WP-919 Expansion Chassis provides circuit board mounting space for installations where additional space is not available within the computer chassis. The expansion chassis has space for two 4-connector system units or one 9-connector system unit.

Front panel access provides easy removal of circuit boards.

A removable power supply unit provides self-contained power for the circuit boards. A fan provides forced air cooling for the cabinet.

2. SPECIFICATIONS -

Capacity: Holds two DEC 4-position system units or one 9-position system unit.

Size: Fits into standard 19 inch RETMA equipment rack.
Height: 5.25 inches
Depth: 16 inches (12 inches with power supply mounted separately.)

Weight: Approximately 60 pounds (27 kilograms) including power supply.

Cooling: Separate fan for both expansion cabinet and power supply.

Controls: Fuse (5A FB) and power switch located on front panel.

Mounting: Slide mounted.

Environment: Temperature = 0° - 50° C
Humidity = 0 to 95% non-condensing
Altitude = to beyond 20,000 feet

Power Supply: Discussed separately.

ASSEMBLY INSTRUCTIONS
WP91988 EXPANSION CHASSIS
TC-130/TC-150/DC-230 BOARDS

1. Remove top cover and front panel; panel is held on with snap fasteners.
2. Remove chassis retaining strap and slide interior chassis out until the spring loaded pin engages hole in exterior chassis.
3. The system unit connector block near back of chassis will be visible from the front. Slots are numbered sequentially downward starting with #1 at the top. The label attached to the support strap in the chassis indicates the locations of the subassemblies for Steps 4, 5 and 6 below.
4. Install unibus cable connector and bus terminator board.
5. Install all Western Peripherals controller boards. These boards should engage card guides on right side of cabinet.
6. Install tape drive cables on ends of TC-130/TC-150 boards, disc drive cables on ends of DC-230 boards.
7. Remove strain relief brackets and dress all cables across top of boards and out slot at rear of chassis over power supply. Install strain relief brackets over cables and tighten screws.
8. Slide interior chassis back into exterior chassis and install chassis retaining strap.
9. Replace top cover and install chassis in cabinet or rack.
10. Replace front panel.

ENGINEERING DRAWINGS

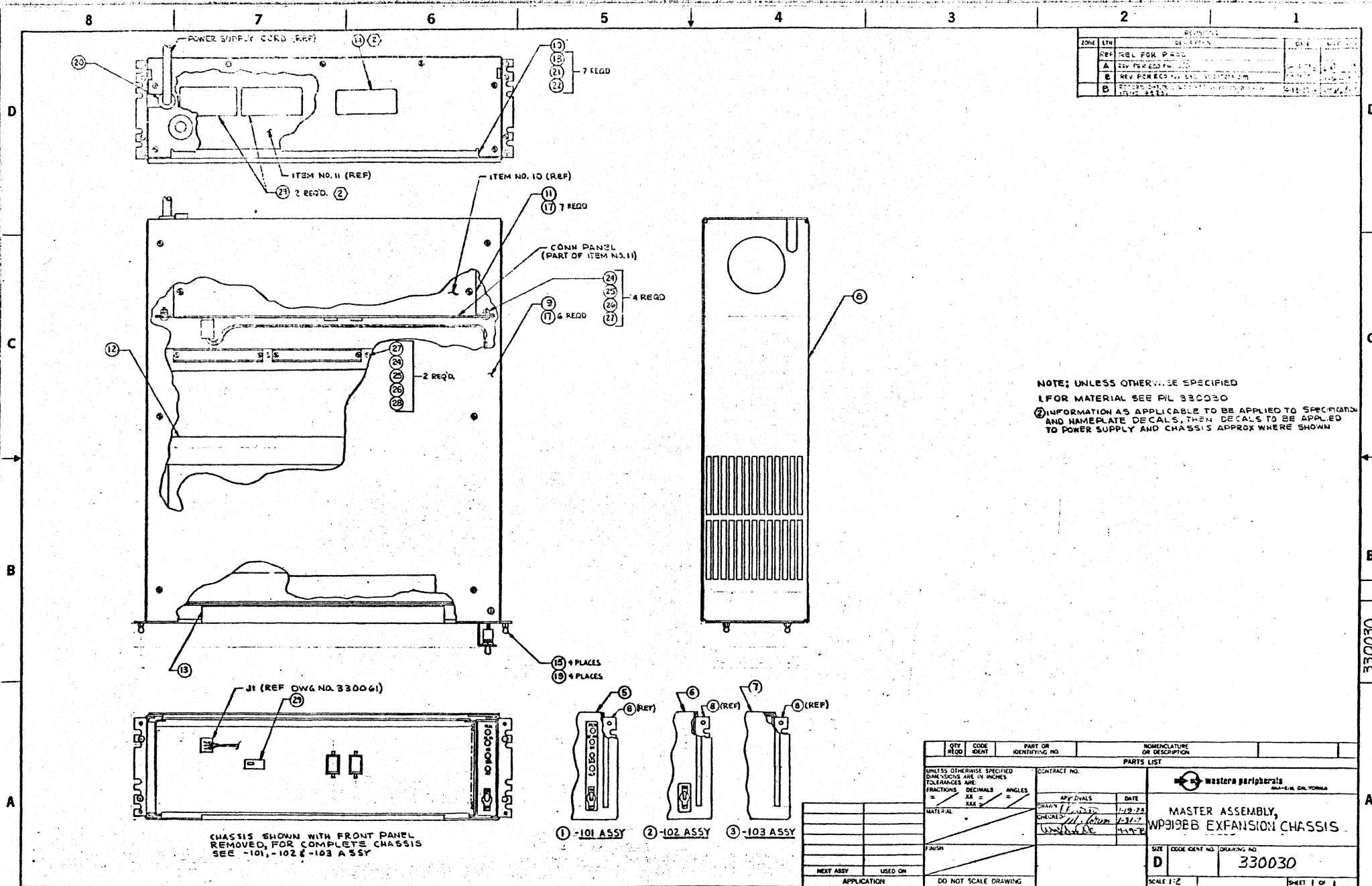

ZONE	LTN	REVISION	DATE
REF	REL FOR PROD		
A	REV PER ECO		
B	REV PER ECO		
C	REV PER ECO		
D	REV PER ECO		

NOTE: UNLESS OTHERWISE SPECIFIED
 IF FOR MATERIAL SEE P/L 330030
 INFORMATION AS APPLICABLE TO BE APPLIED TO SPECIFICATIONS AND NAMEPLATE DECALS, THEN DECALS TO BE APPLIED TO POWER SUPPLY AND CHASSIS APPROX WHERE SHOWN

QTY	CODE	PART OR IDENTIFYING NO.	NOMENCLATURE OR DESCRIPTION
UNLESS OTHERWISE SPECIFIED DIMENSIONS ARE IN INCHES TOLERANCES ARE FRACTIONS DECIMALS ANGLES			
MATERIAL			
FINISH			
NEXT ASSY USED ON APPLICATION			
DO NOT SCALE DRAWING			
CONTRACT NO.		PARTS LIST	
APPROVALS		DATE	
DRAWN		12/9/78	
CHECKED		1/2/79	
DESIGNED		1/2/79	
MATERIAL		4-11-78	
western peripherals			
SAN JOSE, CALIFORNIA			
MASTER ASSEMBLY, WP919BB EXPANSION CHASSIS			
SIZE	CODE	QTY	DRAWING NO.
D			330030
SCALE 1:2		SHEET 1 OF 1	

330030

A

"A" REV. PER ECO NO. 356 6-15-18
 "B" REV. PER ECO NO. 382 8-10-79 me
 (ADD ITEM NO. 29)
 "B" RECORD CHG. PER E.C.O. 482,
 REVERSED QUAN. OF ITEMS 14 & 23

LIST OF MATERIALS

ITEM	VENDOR	PART NUMBER	DESCRIPTION	QUANTITY REQUIRED			DATE RELEASED	JOB ORDER NO.	CORUM	DRAWN BY	DATE	CHECKED BY	DATE	NEXT ASSEMBLY	TITLE PARTS LIST - MAST ER ASSY. WP91988 EXPANSION CHASSIS
				-101 ASSY	-102 ASSY	-103 ASSY									
1		330030-101	CHASSIS ASSY,	/											
2		330030-102	CHASSIS ASSY		/										
3		330030-103	CHASSIS ASSY			/									
4															
5		330033-101	FRONT PANEL	1											
6		330033-102	FRONT PANEL		1										
7		330033-103	FRONT PANEL			1									
8		330031	EXTERNAL CHASSIS	1	1	1									
9		330032	COVER, TOP	1	1	1									
10		330038	PANEL - REAR	1	1	1									
11		330041	POWER SUPPLY	1	1	1									
12		330047	INTERNAL CHASSIS	1	1	1									
13		330037	STRAP, CHASSIS RET	1	1	1									
14		310004	NAMEPLATE,	1	1	1									
15	TINNER-MAN	PI01-625-495	BALL STUD	4	4	4									
16															
17			SCREW-6-32X1/4, 100° FL	13	13	13									
			HD (CROSS REC) CRES												
18			SCREW-6-32 X 1/4 PAN	7	7	7									
			HD (CROSS REC) CRES												
19			SCREW-6-32 X 3/16, 100° FL	4	4	4									
			HD (CROSS REC) CRES												
20	NEYCO	SR6P3-4	STRAIN RELIEF BUSHING	1	1	1					MAY 2 1979				
21			WASHER-NO. 6 FLAT, CRES	7	7	7									
22			WASHER-NO. 6 INT TOOTH	7	7	7									
			LOCK, CRES												
23		310005	SPECIFICATION PLATE	2	2	2									

DATE RELEASED
 JOB ORDER NO.
 CORUM
 DRAWN BY
 DATE
 CHECKED BY
 DATE
 NEXT ASSEMBLY
 SHEET 1 OF 2

ASSEMBLY NO. 330030
 P/L

REV. B

ECRM NC. 002-0049 rev. 1/74

LIST OF MATERIALS

ITEM	DRAWN BY	DATE	PART NUMBER	DESCRIPTION	QUANTITY REQUIRED			CHECKED BY	DATE	NEXT ASSEMBLY	TITLE PARTS LIST- MASTER ASSY, WD 91988 EXPANSION CHASSIS	ASSEMBLY NO. P/L 330030	REV B
					-101 ASSY	-102 ASSY	-103 ASSY						
24				SCREW-8-32 X 3/8	6	6	6						
				PAN HD (CROSS REC) CRES									
25		4-7-78		WASHER NO.8 FLAT, CRES	6	6	6						
26				WASHER NO.8 INT TOOTH LOCK, CRES	6	6	6						
27				NUT, 8-32 HEX, CRES	6	6	6						
28	WALDOM		CCB-7 1/2 I.D.	CABLE CLAMP	2	2	2						
29	THOMAS B BETTS		TC105A	CABLE TIE BRACKET	1	1	1						

DATE RELEASED

JOB ORDER NO.

QUAN

SHEET 2 OF 2

MAY 21 1979

1 M
REV B

FORM NC. 002-0049 rev. 1/74

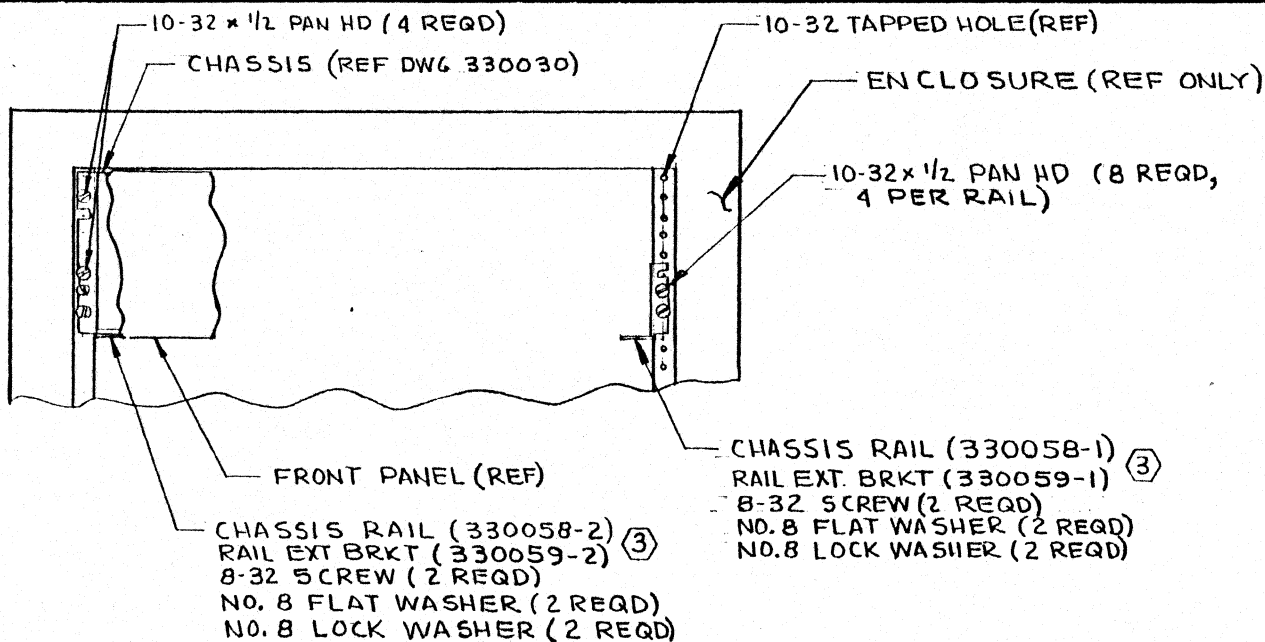

REVISIONS			
LTR	DESCRIPTION	DATE	APPROVED

NOTE: UNLESS OTHERWISE SPECIFIED

1. CHASSIS SHOWN AT TOP OF ENCLOSURE FOR REF TO EIA HOLE PATTERN ONLY.
2. REF PARTS LIST P/L 330065
- ③ CHASSIS RAIL AND RAIL EXT BRKT ARE ADJUSTABLE FROM A MIN LENGTH OF 22.00 TO A MAXIMUM LENGTH OF 30.80
- ④ PARTS NOTED ARE VARIABLE, FOR EXACT TYPE AND QUANTITY REFER TO PURCHASE ORDER OR CUSTOMER SPECIFICATION

PRELIMINARY

TOLERANCES UNLESS OTHERWISE SPECIFIED					
FRACTIONS	DEC.				
±	±	±	INSTALLATION/OUTLINE DWG- WP919BB EXPANSION CHASSIS		
APPROVALS	DATE	SCALE			
DRAWN CORUM	4-26-78	1/4	SIZE B	DRAWING NO. 330065	REV
CHECKED		DO NOT SCALE DRAWING			SHEET 1 OF 2

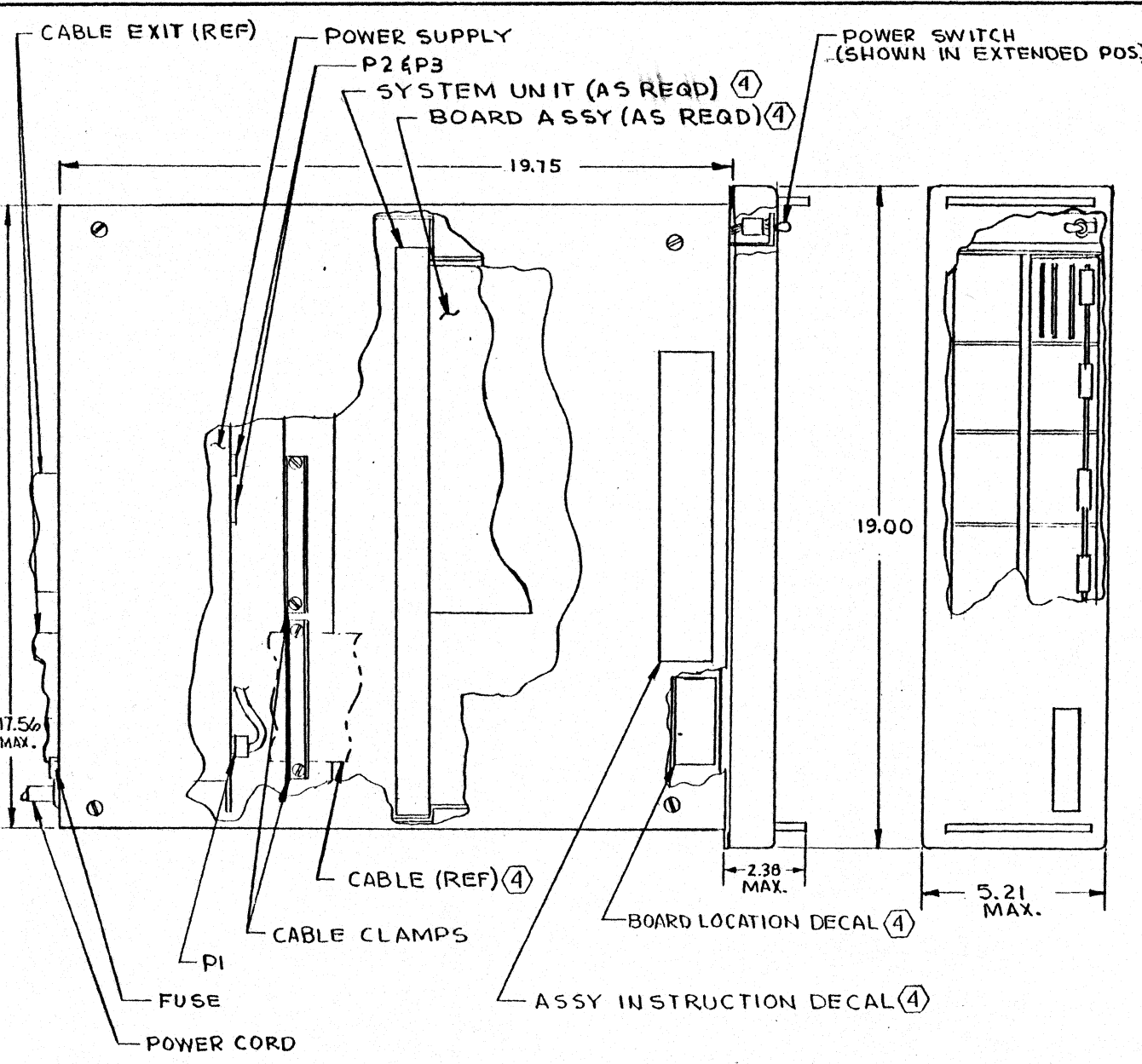

REVISIONS			
LTR	DESCRIPTION	DATE	APPROVED

PRELIMINARY

TOLERANCES UNLESS OTHERWISE SPECIFIED FRACTIONS DEC. ANGLES ± ± ±		 western peripherals ANAHEIM, CALIFORNIA		
APPROVALS	DATE			
DRAWN CORUM	4-27-78			
CHECKED		SCALE	SIZE	DRAWING NO.
		NONE	B	330065
		DO NOT SCALE DRAWING		REV
				SHEET 2 OF 2

		REVISIONS	DATE	APPROVED
ZONE	LTR	DESCRIPTION		
REF		RELEASE FOR PRODUCTION	11-77	
REF		RECORD ENCL. REMOVE MAGNETIC BAND ADD RUBBER STAMP TO FAN (ALL DATE COMPLIANT)		
A		REV. PER ECO NO. 356	6-15-78	J.D. 10-78
B		REV PER ECO NO. 366 (CHG METHOD OF FAN WIRING)	7-17-78	J.D. 7-17-78
C		REV WIRING DIAGRAM PER ECO NO. 384	8-10-78	J.D. 8-10-78
D		ADDED AUX. VIEW & WIRE IDNT. PER ECO # 454	3-9-78	J.D. 3-12-79

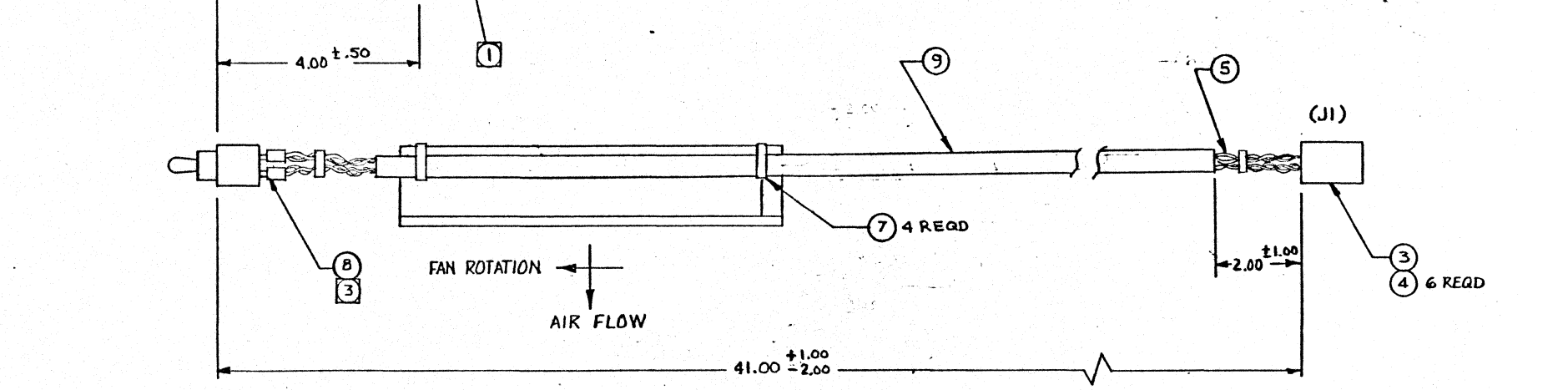
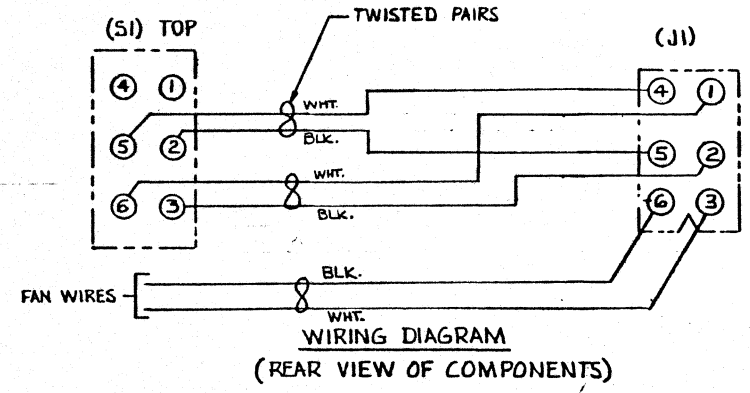
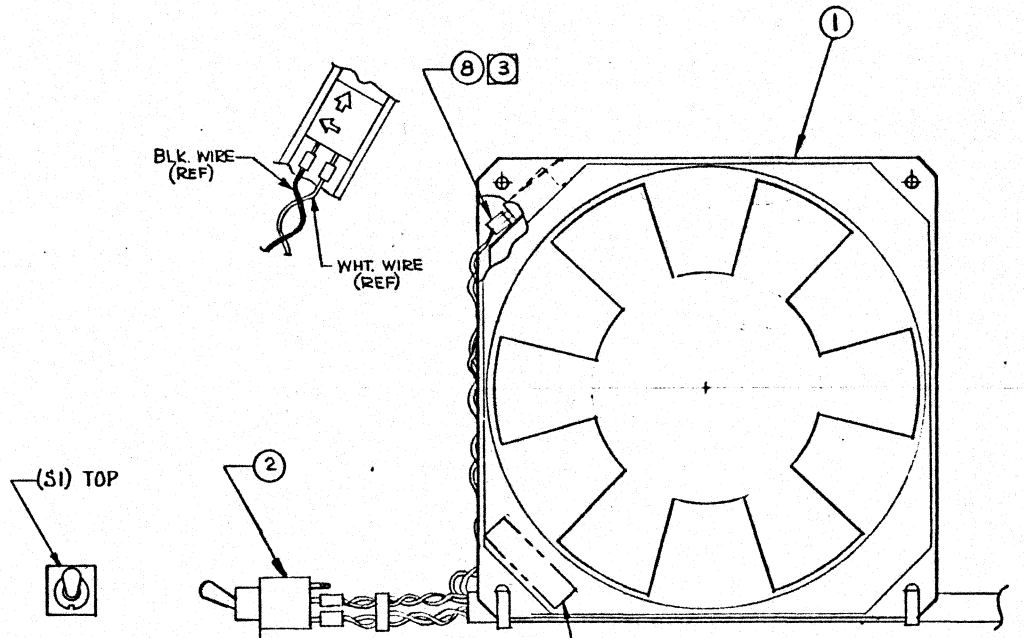

4. FOR MATERIAL SEE P/L 330061
- (3) INSTALL ITEM 8 (SHRINK TUBING) ON ALL SOLDERED TERMINATIONS
- (2)
- (1) MARK WITH PART NO. AND LATEST REV. LTR. APPROX WHERE SHOWN WITH CONTRASTING COLOR.
- NOTES: UNLESS OTHERWISE SPECIFIED

QTY REQD	CODE IDENT	PART OR IDENTIFYING NO.	NOMENCLATURE OR DESCRIPTION
PARTS LIST			
UNLESS OTHERWISE SPECIFIED DIMENSIONS ARE IN INCHES TOLERANCES ARE:		CONTRACT NO.	
FRACTIONS ±	DECIMALS .XX ±.06	ANGLES ±	APPROVALS
	.XXX ±		DATE
MATERIAL		DRAWN <i>[Signature]</i> 1-18-78	
FINISH		CHECKED <i>[Signature]</i> 1-31-78	
NEXT ASSY		SIZE C	
USED ON		CODE IDENT NO.	
APPLICATION		DRAWING NO. 330061	
DO NOT SCALE DRAWING		SCALE NONE	
		SHEET 1 OF 1	

330061

REVISIONS			
LTR	DESCRIPTION	DATE	APPROVED
A	REV PER CO# 0128	2-4-77	J.D. 2-15-77

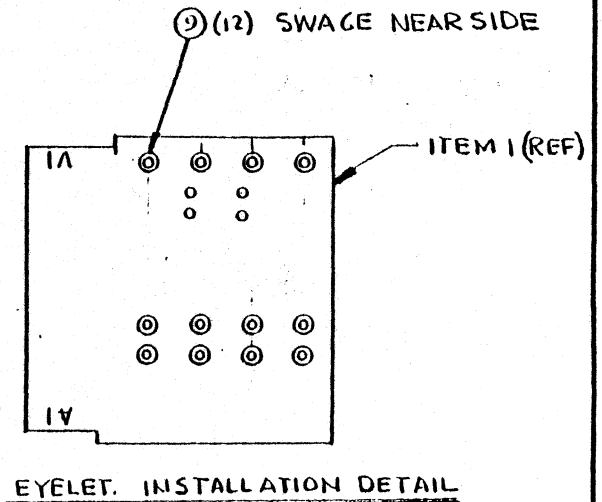
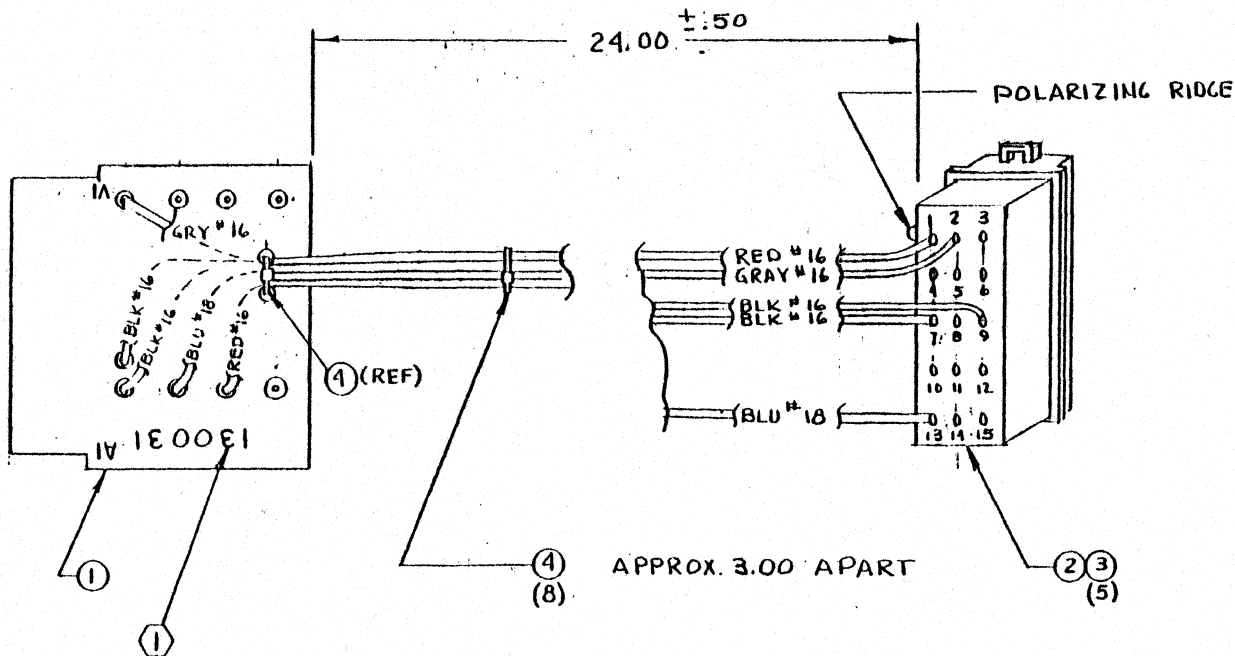

2. FOR MATL SEE PARTS LIST 130031
 (1) RUBBER STAMP ASSY NO. & LATEST REV
 I LTR WHERE SHOWN USING BLK INK
 NOTE: UNLESS OTHERWISE SPECIFIED

TOLERANCES UNLESS OTHERWISE SPECIFIED FRACTIONS DEC. ANGLES ± ± ±		 western peripherals ANAHEIM, CALIFORNIA	
APPROVALS		DATE	
DRAWN FORUM		6-17-74	
CHECKED J.D.		6-22-76	
SCALE FULL		SIZE B	DRAWING NO. 130031
DO NOT SCALE DRAWING		REV A	
		SHEET 1 OF 1	

REVISIONS			
LTR	DESCRIPTION	DATE	APPROVED
A	PRODUCTION RELEASE	6-9-78	W.D.
B	CHG. LENGTH FROM 56 IN. PER E.C.O. 36B	7-14-78 W.D.	7-18-78

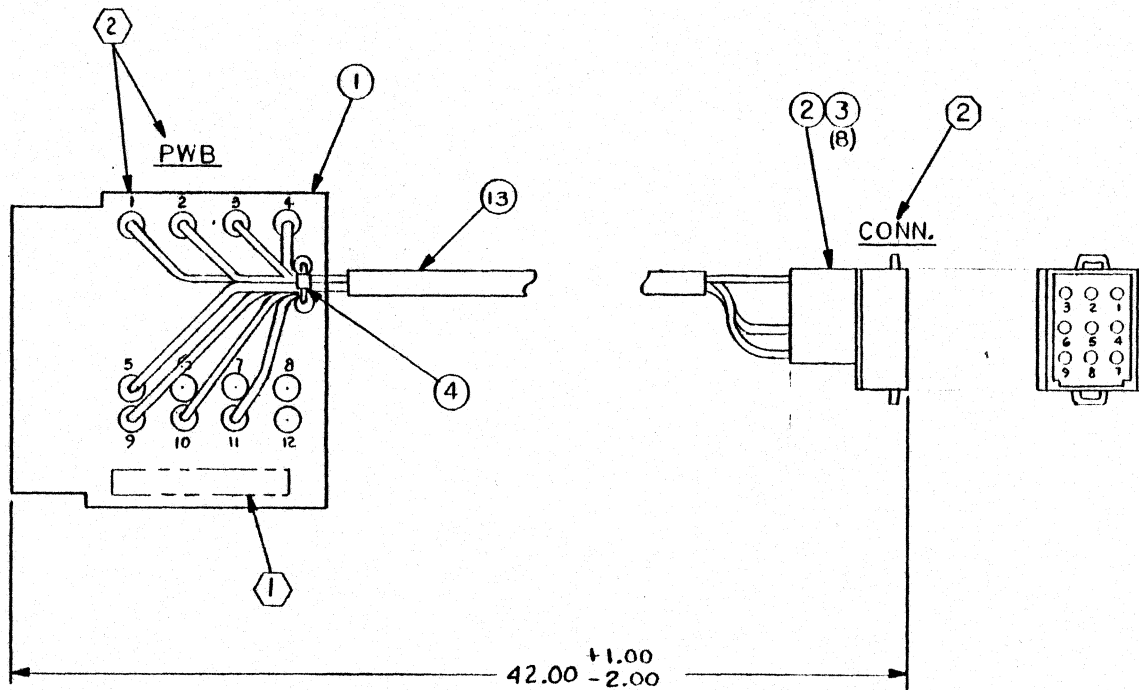

NOTES: UNLESS OTHERWISE SPECIFIED

- ① RUBBER STAMP ASSY. No. WITH LATEST REV. LTR. LOCATED WHERE SHOWN.
- ② NUMBERS AND CHARACTERS ARE FOR REF. ONLY AND DO NOT APPEAR ON PART.
- ③ FOR MATERIAL SEE PARTS LIST 62000005-00A

WIRING TABLE			
WIRE NO.	SIZE (COLOR)	FROM PWB	TO CONN.
1	AWG 14 (GRAY)	1	PIN No. 8
2	14 (VIO.)	2	1
3	14 (YEL.)	3	2
4	14 (BRN.)	4	7
5	14 (BLK.)	5	5
6	14 (BLK.)	9	4
7	14 (BLUE)	10	3
8	AWG 14 (RED)	11	PIN No. 9

TOLERANCES UNLESS OTHERWISE SPECIFIED		western peripherals ANAHEIM, CALIFORNIA		
FRACTIONS DEC.	ANGLES			
±	±	ASSEMBLY-CABLE WP 919 BB/DC POWER		
APPROVALS	DATE			
DRAWN P. CHAPMAN	6-8-78	SCALE	SIZE B	DRAWING NO. 62000005
CHECKED W. Aufsch.	6-9-78			
DO NOT SCALE DRAWING		SHEET 1 of 1		

REVISIONS			
LTR	DESCRIPTION	DATE	APPROVED
A	RELEASED FOR PRODUCTION	5-22-79	IR. Martinez

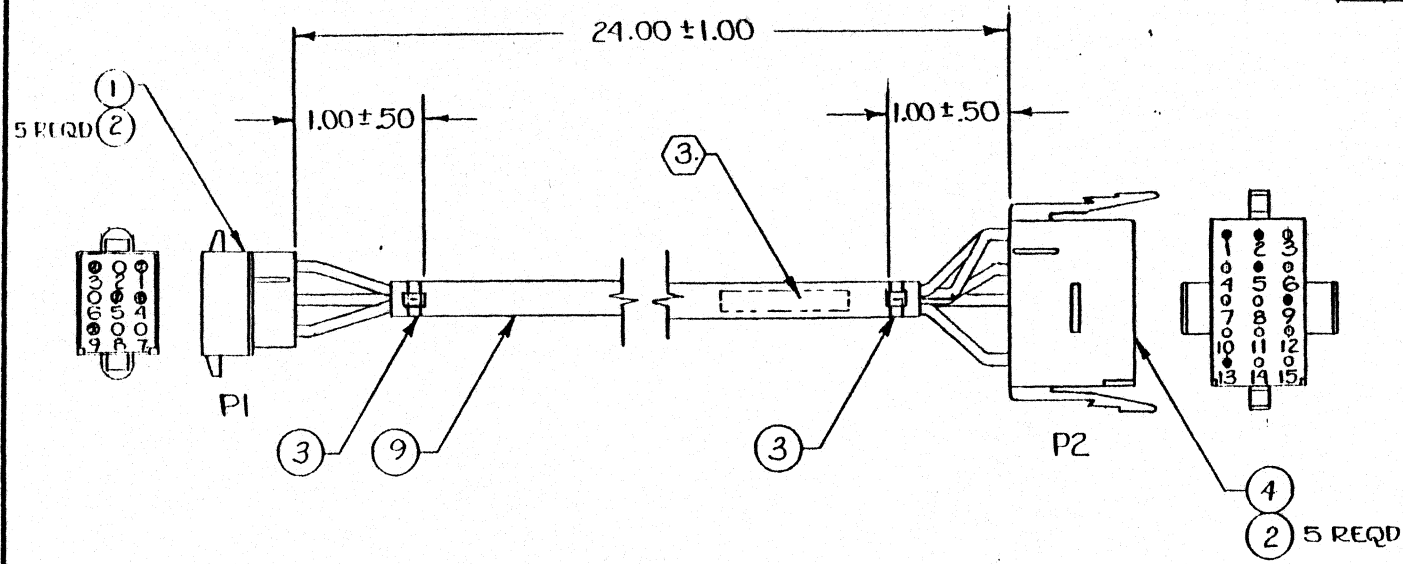

WIRE TABLE - P1		
CONN PIN	COLOR	FUNCTION
PI-1	GRAY	+15V
PI-2	—	—
PI-3	BLUE	-15V
PI-4	BLACK	GND
PI-5	BLACK	GND
PI-6	—	—
PI-7	—	—
PI-8	—	—
PI-9	RED	+15V

WIRE TABLE - P2		
CONN PIN	COLOR	FUNCTION
P2-1	RED	+15V
P2-2	GRAY	+15V
P2-3	—	—
P2-4	—	—
P2-5	BLACK	GND
P2-6	—	—
P2-7	—	—
P2-8	—	—
P2-9	BLACK	GND
P2-10	—	—
P2-11	—	—
P2-12	—	—
P2-13	BLUE	-15V
P2-14	—	—
P2-15	—	—

MAY 30 1979

- (3) MARK ASSY NO. AND LATEST REV LETTER USING WHITE INK APPROX WHERE SHOWN
2. FOR MAT'L SEE PL 44001758
1. ALL WIRE #14 GA STRANDED

NOTE:

TOLERANCES UNLESS OTHERWISE SPECIFIED FRACTIONS DEC ANGLES ± ± ±		WESPERLINE™ <small>Division of WESPERCORP ANAHEIM, CALIFORNIA</small>	
APPROVALS DRAWN: <i>SRC</i> CHECKED: <i>J. Bennett</i>		DATE 12/11/78 12/11/78	
ASSEMBLY, EXTENSION CABLE		SCALE ~	SIZE DRAWING NO. B 44001758
DO NOT SCALE DRAWING		SHEET 1	

2-3

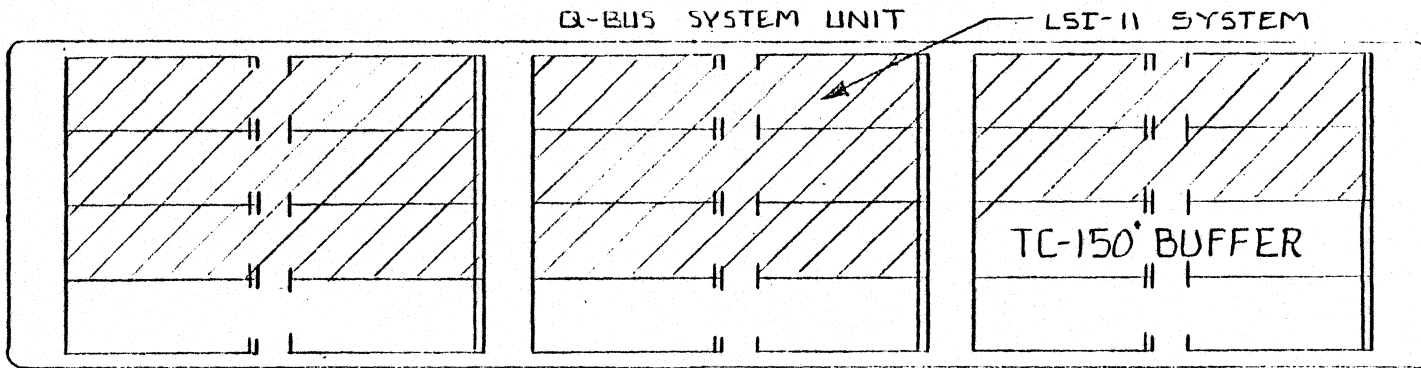

WARNING: ORIENT POWER CONNECTOR AS INDICATED

COMPONENT SIDE OF BOARDS - SIDE 1

TAPE CONTROLLER SYSTEM UNIT
MODEL WP-933 LT ASSEMBLY 131023

- 1
- 2
- 3
- 4

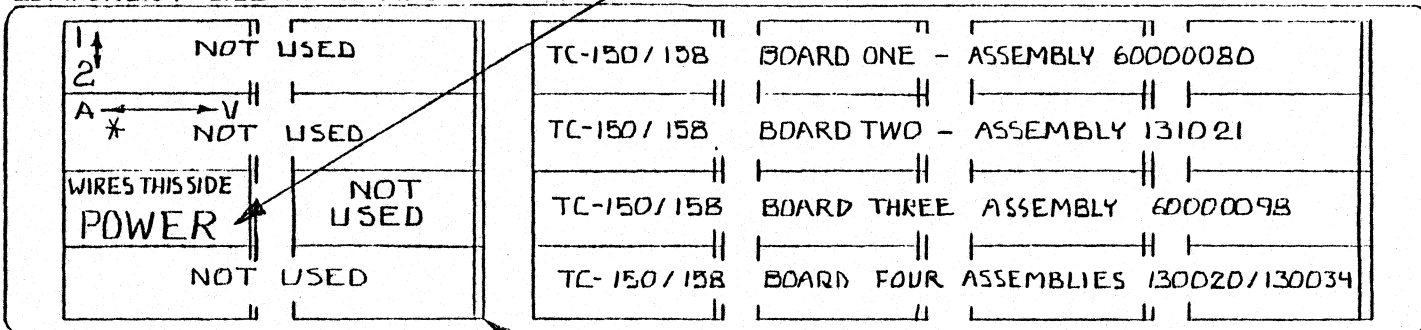

SOLDER SIDE OF BOARDS - SIDE 2

* CONNECTOR PIN NUMBERING OMITTS LETTERS: G, I, D, Q

A B C D E F

CONNECTOR RIDGE

LSI-II / TC-150 SYSTEM CONFIGURATION
(HEX)

2-3 A

TAPE CONTROLLER SYSTEM UNIT
MODEL WP9270T
ASSEMBLY 64000052

COMPONENT SIDE OF BOARDS - SIDE ONE

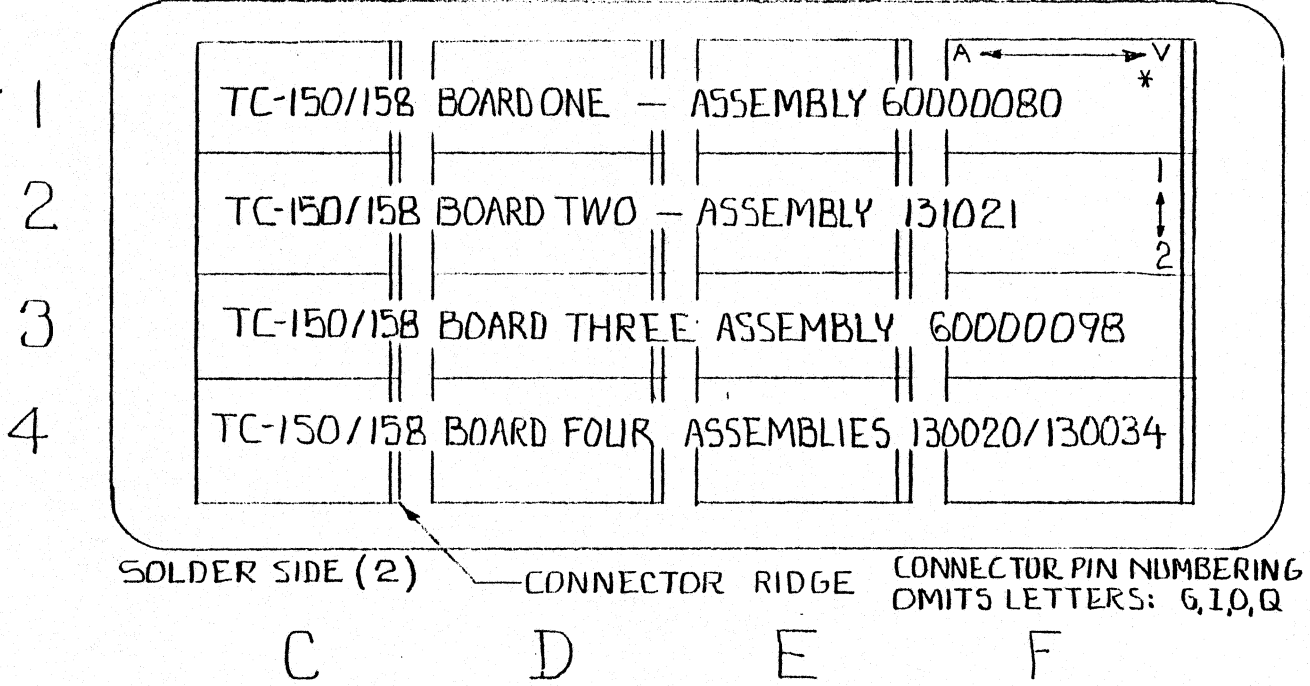

TC-150 SYSTEM CONFIGURATION
(QUAD)

NOTE: Items shown in parentheses provide an example of possible configurations. Jumper each unused A, C, and E connector from pin M2 to pin N2 and from pin R2 to pin S2.

NUMBERS INDICATE Q-BUS PRIORITY
COMPONENT SIDE OF BOARDS - SIDE 1

Q-BUS / TAPE CONTROLLER SYSTEM UNIT
MODEL WP-934 LTQ ASSEMBLY 82000001

Q-3B

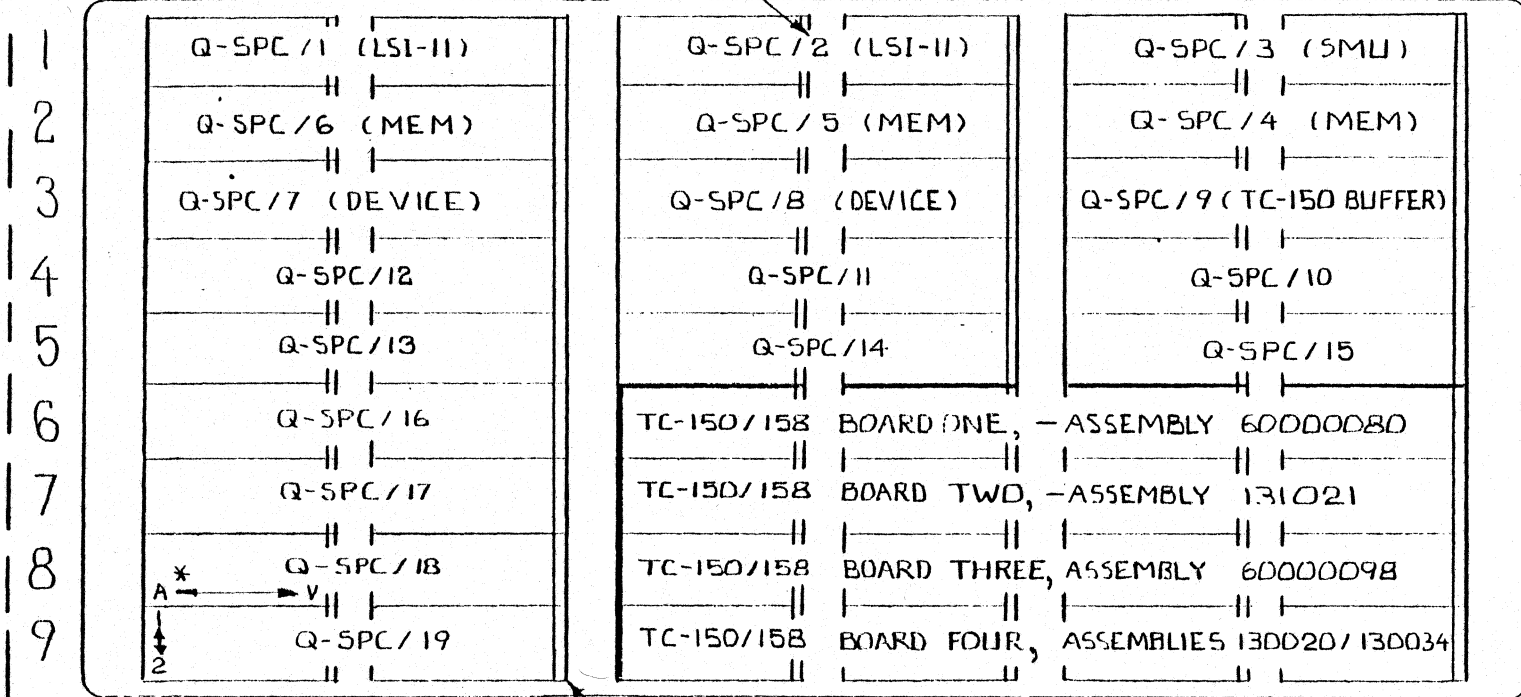

SOLDER SIDE OF BOARDS - SIDE 2

* CONNECTOR PIN NUMBERING OMIT'S LETTERS: G, I, O, Q

A

B

C

D

E

F

CONNECTOR RIDGE

LSI-II / TC-150 SYSTEM CONFIGURATION
(9 - WIDE)

LSI-11 CONNECTOR SLOT PRIORITY JUMPERING

The Bus Interrupt Acknowledge and Bus DMA Grant lines must be jumpered at all unused connector slot positions (from the Processor to the Bus Terminator); two jumper techniques are available:

1. Western Peripherals jumper cards (part number 76000223) may be used.
2. Wire-wrap techniques may be used for priority jumpers as follows:

	Connector Positions A,C, or E
Bus Interrupt Acknowledge	Jumper pin M2 to pin N2
Bus DMA Grant	Jumper pin R2 to pin S2

Note: Letters G, I, O, and Q are skipped in the connector pin numbering scheme.

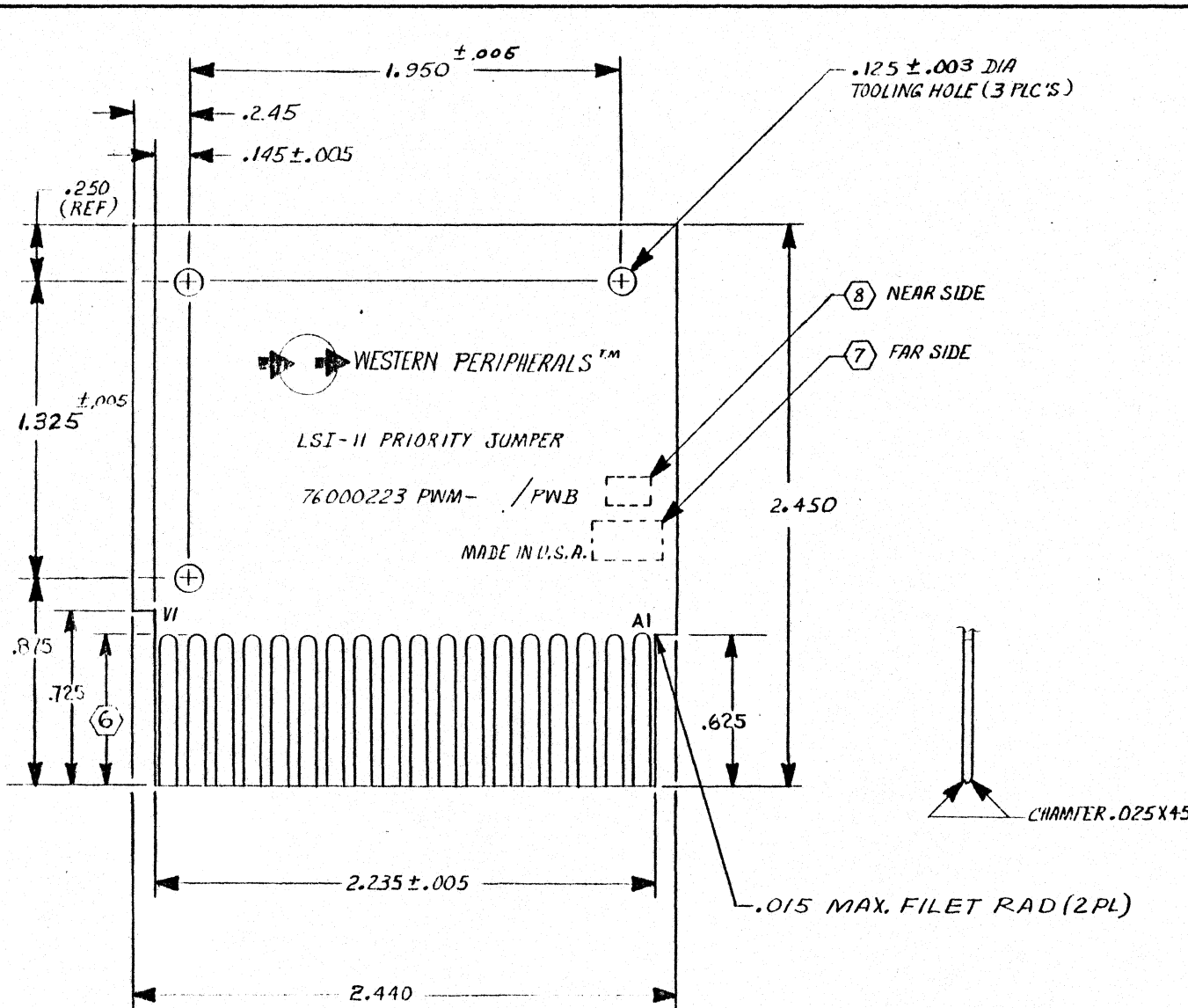

REVISIONS			
LTR	DESCRIPTION	DATE	APPROVED
A	REL FOR PRODUCTION	5-24-79	CC
B	REVERSED .625 & .725 CUTOUTS PER ECO 509	7-5-79	WJ

JUL 5 1979

- NOTE: UNLESS OTHERWISE SPECIFIED.
- USE ARTWORK MASTER 76000223.
 - MATERIAL: FIBERGLASS TYPE FR4, .055 ± .005 THK INCLUDING 2 OZ COPPER BOTH SIDES (AFTER PLATING) COLOR: GREEN.
 - HOLE REGISTRATION TO BE WITHIN .005 OF TRUE POSITION.
 - FRONT TO BACK REGISTRATION TO BE WITHIN .005 OF TRUE POSITION.
 - TOLERANCE ON 3 PLACE DECIMALS (.XXX) IS ± .010
 - CONTACT FINGERS TO BE GOLD PLATED .00005 MIN-.00010 MAX. OVER .00005 MIN THK STAINLESS STEEL NICKEL PLATING.
 - FINISHED BOARD SHALL MEET FLAMMABILITY RATINGS OF U.L. 94V-2 OR BETTER AND BE PERMANENTLY MARKED IN AREA SHOWN WITH FABRICATOR'S LOGO, TRADEMARK OR APPROVED INITIALS FOLLOWED BY THE FABRICATOR'S U.L. APPROVED RECOGNITION CODE.
 - STAMP REV LTR OF THIS FAB DWG USING BLACK ETCHING INK WHERE SHOWN AND APPLY PROTECTIVE COAT OF CLEAR ACRYLIC ABLE TO WITHSTAND CLEANING WITH FREON.

TOLERANCES UNLESS OTHERWISE SPECIFIED		 ANAHEIM, CALIFORNIA	
FRACTIONS	DEC.	ANGLES	FABRICATION DRAWING
±	±	±	LSI-II PRIORITY JUMPER
APPROVALS	DATE	SCALE	SIZE
DRAWN A. L. ...	5/22/79	2X	B
CHECKED C. ...	5-24-79	DRAWING NO.	76000223
DO NOT SCALE DRAWING			SHEET 1 OF 1

POWER SUPPLY

POWER SUPPLY

GENERAL DESCRIPTION

The Power Supply is fully adjustable using integrated circuit regulators and series pass transistor technology. The main supply (+5V) features foldback current limiting and an adjustable overvoltage (crobar/fuse-type) protection circuit. The transformer may be tapped for either the 115V or the 230V line voltage ranges.

1. INPUT

- A. Voltage 115/230 VAC \pm 10%
- B. Frequency 47-63/360-440 Hz

2. OUTPUT VOLTAGE

A. +5 VDC, 0-15 amps continuous

- 1. Adjustable \pm .7V with cover removed.
- 2. Ripple 10 mV maximum peak-to-peak under all conditions of load and line.
- 3. Regulation 4% voltage variation under worst case load and line conditions.
- 4. Current limiting using fold back mode at 110-150% maximum current.
- 5. Overvoltage protected at 6.3 ± 0.3 volts with fuse.

B. +15 VDC, 0-2 amp continuous

- 1. Adjustable 12 to 15V with cover removed.
- 2. Ripple 10 mV maximum peak-to-peak under all load conditions.
- 3. Regulation 3% maximum variation under all load and line conditions.

C. -15 VDC, 0-2 amps continuous

- 1. Adjustability, ripple and regulation, same as 2b above.

D. The +5 VDC return, +15 VDC return and the -15 VDC return shall be tied together in the power supply.

3. ENVIRONMENTAL

A. Temperature

1. 0-50 degrees C ambient air under all load and line.
Forced air cooling is provided by fan which operates on the input voltage and frequency.

B. Humidity

1. 0-95% non-condensing.

C. Altitude

1. Operation to 20,000 feet under all conditions.
2. Storage to 50,000 feet without deleterious effects.

D. Shock and Vibration

1. The power supply has been designed to the best commercial standards.

4. PHYSICAL

A. The weight shall not exceed 15 lbs.

B. The physical dimensions, fuse location, input and output location, identification and power cord will be as specified by WESTERN PERIPHERALS Drawing 330041.

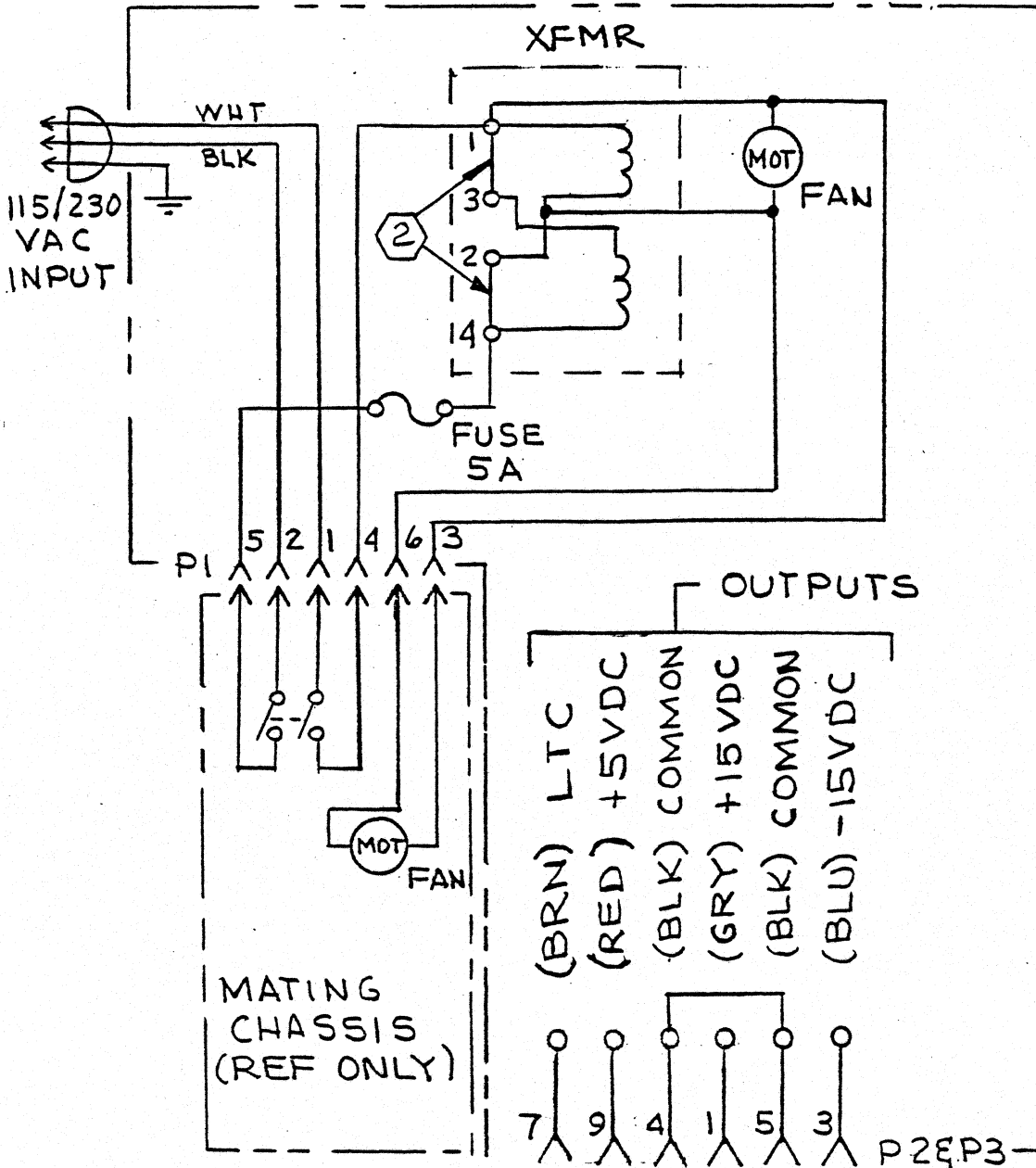

NOTE:

1. EXHAUST FAN WIRED TO OPERATE WHEN INPUT VOLTAGE APPLIED TO POWER SUPPLY

② FOR 230 VAC OPERATION REMOVE JUMPER WIRES FROM TERMINALS 1 TO 3 AND 2 TO 4 AND ADD JUMPER FROM TERMINAL 2 TO TERMINAL 3 ON TRANSFORMER

VENDOR: POWER COMPONENTS

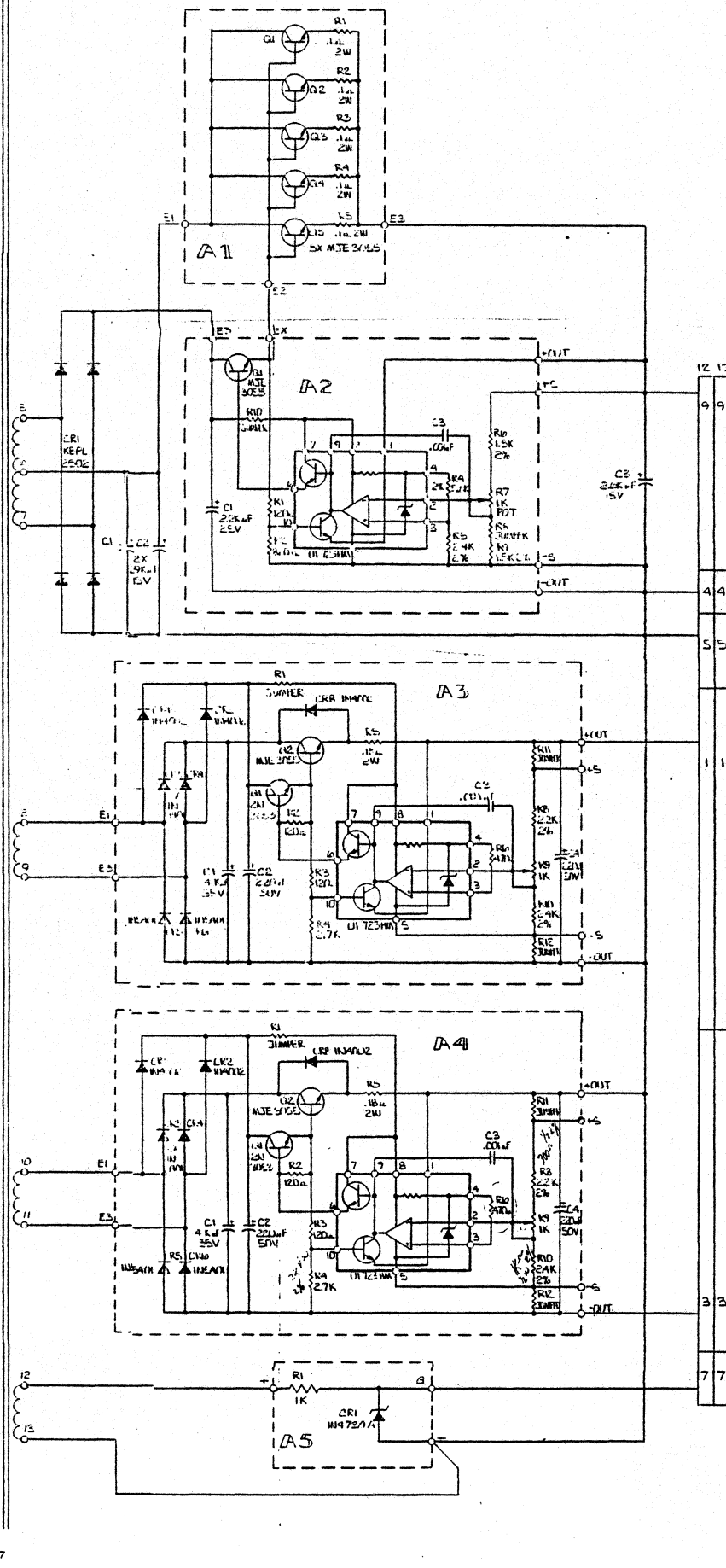
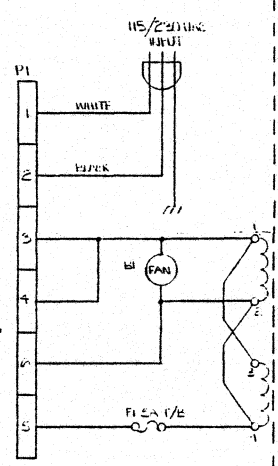

LTR	REVISIONS	DESCRIPTION	DATE	APPROVED

USED ON	TOLERANCES UNLESS
MODELS:	OTHERWISE SPECIFIED
911	FRACTIONS DEC. ANGLES
919	

APPROVALS	DATE
±	±
±	±
±	±
±	±
±	±

western peripherals
ANAHEIM, CALIFORNIA

SCHWARTZ
POWER SUPPLY C-676

SCALE: **B** 91000141-004

DO NOT SCALE DRAWING

SIZE: DRAWING NO. 91000141-004

SHEET

REVISIONS			
LTR	DESCRIPTION	DATE	APPROVED
B	ECO NO. 387	8-23-78	WEGM

THE WP-919 EXPANSION CHASSIS ASSEMBLY CONSISTS OF THE FOLLOWING:

PART NO.	QTY.	DESCRIPTION	REV.
330034-2	1	FRONT PANEL (330030-102 ASSY)	A
330035	2	BRACKET-FRONT PANEL MTG.	B
330048	1	WELD ASSY-INTERNAL CHASSIS	B
330049	1	PANEL-RIGHT SIDE	B
330050	1	PANEL-LEFT SIDE	B
330051	1	SUPPORT BAR-STRAIN RELIEF	A
330052	1	SUPPORT PLATE-BOTTOM	NC
330053	1	SUPPORT STRAP-LOWER FRONT	NC
330054-1	1	SUPPORT STRAP	NC
330054-2	2	SUPPORT STRAP	NC
330055	2	BRACKET-STRAIN RELIEF	NC
330056	1	BRACKET-SLIDE SWITCH MTG.	NC
330057	2	EXTENSION CLIP SWITCH MTG.	NC
330031	1	EXTERNAL CHASSIS	A
330032	1	TOP COVER	B
330038	1	REAR PANEL	A
330037	1	STRAP-CHASSIS RETAINER	B
330058-1	1	RAIL-CHASSIS MTG.	NC
330058-2	1	RAIL-CHASSIS MTG.	NC
330059-1	1	RAIL-CHASSIS MTG.	A
330059-2	1	RAIL-CHASSIS MTG.	A

APR 11 1979

OPTIONS:
 1. BLANK FRONT PANEL NO. 330034-3
 2. FRONT PANEL WITH SWITCH CUTOUT NO. 330034-1
 MUST BE ORDERED SEPARATELY.

TOLERANCES UNLESS OTHERWISE SPECIFIED		 western peripherals ANAHEIM, CALIFORNIA		
FRACTIONS	DEC. ANGLES			
±	± ±	FABRIKATION SPECIFICATION CONTROL DRAWING. MODEL NO. WP-919		
APPROVALS	DATE			
DRAWN <i>W. Hartman</i>	6-21-78	SCALE	SIZE A	DRAWING NO. 44000115
CHECKED <i>W. Hartman</i>	7-18-78			
		DO NOT SCALE DRAWING		SHEET / OF 1